

UNIVERSIDAD SAN FRANCISCO DE QUITO USFQ

Colegio de Ciencias e Ingenierías

**Estudio de la Trayectoria de Deposito de Recubrimientos por
Metalización para álabes de turbinas Pelton mediante el brazo
robótico KUKA KR20**

Andrés Cruz Vargas

Ingeniería Mecánica

Trabajo de integración curricular presentado como requisito
para la obtención del título de
Ingeniero Mecánico

Quito, 06 de diciembre de 2019

UNIVERSIDAD SAN FRANCISCO DE QUITO USFQ
COLEGIO DE CIENCIAS E INGENIERÍA

HOJA DE CALIFICACIÓN
DE TRABAJO DE INTEGRACIÓN CURRICULAR

**Estudio de la Trayectoria de Deposito de Recubrimientos por Metalización
para álabes de turbinas Pelton mediante el brazo robótico KUKA KR20**

Andrés Cruz Vargas

Calificación:

Nombre del profesor, Título académico

Alfredo Valarezo, Ph.D.

Firma del profesor:

Quito, 06 de diciembre de 2019

Derechos de Autor

Por medio del presente documento certifico que he leído todas las Políticas y Manuales de la Universidad San Francisco de Quito USFQ, incluyendo la Política de Propiedad Intelectual USFQ, y estoy de acuerdo con su contenido, por lo que los derechos de propiedad intelectual del presente trabajo quedan sujetos a lo dispuesto en esas Políticas.

Asimismo, autorizo a la USFQ para que realice la digitalización y publicación de este trabajo en el repositorio virtual, de conformidad a lo dispuesto en el Art. 144 de la Ley Orgánica de Educación Superior.

Firma del estudiante:

Nombres y apellidos:

Andrés Cruz Vargas

Código:

00121400

Cédula de identidad:

1804194692

Lugar y fecha:

Quito, 06 de diciembre de 2019

RESUMEN

El trabajo presenta el estudio para la generación de trayectorias mediante programación punto-a-punto con la ayuda de un brazo robótico KUKA KR20 para realizar el proceso de metalización en un modelo a escala 1:5 del álabe de una Turbina Pelton realizado con una torcha de rociado térmico Oerlikon Metco 5P-II. Se generó dos trayectorias con las cuales se pudo conocer cuál es la mejor para obtener propiedades del recubrimiento aceptables. Se midió la temperatura proporcionada por el proceso de metalización hacia el sustrato, mismo que sirvió de guía para poder realizar una estimación de los esfuerzos residuales generados en el recubrimiento mediante una simulación de elementos finitos. Por otro lado, se midió y analizó los espesores en toda la extensión del recubrimiento mediante un medidor de espesor de revestimientos Elcometer 456 para determinar la homogeneidad de este y así poder determinar la trayectoria más aceptable.

Palabras clave: Metalización, KUKA KR20, Thermal Spray, Trayectorias de Recubrimiento, Elcometer 456.

ABSTRACT

The paper presents the generation of trajectories by means of point-to-point programming with the usage of a KUKA KR20 robotic arm. The trajectory is used to perform the spraying process in a 1: 5 scale model of the blade of a Pelton turbine performed with a flame spray torch Oerlikon Metco 5P-II. Two trajectories were generated to compare acceptable coating properties. The temperature rise due to the spraying process over the substrate was measured. The temperature served as an input variable to calculate the residual stresses generated in the coating by means of a simulation of finite elements. On the other hand, the thickness in the entire length of the coating was measured and analyzed by means of an Elcometer 456 Coating thickness gauge to determine its homogeneity and thus to be able to determine the most acceptable trajectory.

Keywords: Flame spray, KUKA KR20, Thermal Spray, Coating Paths, Trajectories.

TABLA DE CONTENIDO

Introducción.....	10
Métodos y Materiales	14
Generación del álabe de una turbina Pelton.....	14
Sistema de medición de Temperatura	16
Metalización en el modelo del álabe	18
Trayectorias generadas para los recubrimientos	27
Medición del espesor del recubrimiento	29
Simulación de esfuerzos residuales	30
Discusión y Resultados.....	32
Resultados	32
Trayectoria A.....	32
Trayectoria B.....	38
Discusión.....	46
Trayectoria A.....	46
Trayectoria B.....	46
Conclusiones	47
Trabajo Futuro.....	48
Referencias	49
Anexos	51

Código para la programación de la Trayectoria A.....	51
Extensión .src	51
Extensión .dat	60
Código para la programación de la Trayectoria B	69
Extensión .src	69
Extensión .dat	96

Índice de Tablas

Tabla 1 Errores de recubrimiento para varias formas de superficie.	12
Tabla 2 Entradas para la simulación de esfuerzos residuales.	31

Índice de Figuras

Figura 1 Trayectoria angular muy extensa. (Fang et al, 2010)	11
Figura 2 Trayectoria del proceso de metalización	12
Figura 3 CAD del Rodete de una Turbina Pelton.	14
Figura 4 CAD del Alabe de una Turbina Pelton.	15
Figura 5 Impresión en 3D del álabe en escala 1:5	15
Figura 6 Plantilla en 2D del álabe en escala 1:5	15
Figura 7 Modelo a escala 1:5 del álabe en acero de 0.5mm de espesor	16
Figura 8 Distribución en el Alabe de las termocupas	17
Figura 9 Recubrimiento para protección de termocupas	17
Figura 10 Circuito generado para la medición de temperatura.	18
Figura 11 Diagrama del circuito para la medición de temperatura	18
Figura 12 Torcha de termorociado Oerlikon Metco 5P-II anclada a un brazo robótico KUKA KR20.	19
Figura 13 Método de calibración de herramienta de trabajo XYZ 4-Puntos.	20
Figura 14 Método de calibración de mesa de trabajo de los 3 puntos.	21
Figura 15 Reemplazo del TCP.	23
Figura 16 Navegador	24
Figura 17 Pantalla del programa.	25
Figura 18 Línea de comandos.	26
Figura 19 Trayectoria A.	27
Figura 20 Trayectoria B.	28
Figura 21 Sectores donde se realizaron las mediciones de espesor del recubrimiento (A y B).	29
Figura 22 Medidor de Espesor de Revestimientos Elcometer 456.	30
Figura 23 CAD en Abaqus para la simulación de esfuerzos residuales con la localización de los diferentes nodos con sus diferentes temperaturas.	30
Figura 24 Espesores del Recubrimiento a lo largo del Alabe "A"	32
Figura 25 Distribución de la Temperatura del Sustrato durante el Recubrimiento del Alabe "A"	33
Figura 26 Distribución de la Temperatura del Sustrato durante el Enfriamiento del Alabe "A"	34
Figura 27 Simulación de Esfuerzos Residuales para la Trayectoria A (Esfuerzos en S11)	35
Figura 28 Simulación de Esfuerzos Residuales para la Trayectoria A (Esfuerzos en S22)	36
Figura 29 Simulación de Esfuerzos Residuales para la Trayectoria A (Esfuerzos en S33)	36
Figura 30 Simulación de Esfuerzos Residuales para la Trayectoria A (Esfuerzos en S12)	37
Figura 31 Simulación de Esfuerzos Residuales para la Trayectoria A (Esfuerzos en S13)	37
Figura 32 Simulación de Esfuerzos Residuales para la Trayectoria A (Esfuerzos en S23)	38
Figura 33 Simulación de Esfuerzos Residuales para la Trayectoria A (Esfuerzos de VonMises)	38
Figura 34 Espesores del Recubrimiento a lo largo del Alabe "B"	39
Figura 35 Distribución de la Temperatura del Sustrato durante el Recubrimiento del Alabe "B"	40

Figura 36 Distribución de la Temperatura del Sustrato durante el Enfriamiento del Alabe "B"	41
Figura 37 Simulación de Esfuerzos Residuales para la Trayectoria B (Esfuerzos en S11)	42
Figura 38 Simulación de Esfuerzos Residuales para la Trayectoria B (Esfuerzos en S22)	43
Figura 39 Simulación de Esfuerzos Residuales para la Trayectoria B (Esfuerzos en S33)	43
Figura 40 Simulación de Esfuerzos Residuales para la Trayectoria B (Esfuerzos en S12)	44
Figura 41 Simulación de Esfuerzos Residuales para la Trayectoria B (Esfuerzos en S13)	44
Figura 42 Simulación de Esfuerzos Residuales para la Trayectoria B (Esfuerzos en S23)	45
Figura 43 Simulación de Esfuerzos Residuales para la Trayectoria B (Esfuerzos de VonMises)	45
Figura 44 Trayectoria generada por dos tramados.	48

INTRODUCCIÓN

A medida que la tecnología ha ido aumentando, los brazos robóticos han sido una gran ayuda para muchos procesos de manufactura debido a su gran facilidad de programación y adaptabilidad a distintas geometrías. En el caso del recubrimiento por metalización mediante Thermal Spray; Deng et al. (2014) explican que, en ciertos casos, el movimiento de los brazos robóticos no puede llegar a ofrecer completamente los parámetros definidos para este proceso como el ángulo de impacto y la velocidad relativa entre la antorcha y el sustrato, debido a que mediante este proceso se presentan diferentes influencias como la transferencia de masa y calor durante la generación de cualquier recubrimiento por metalización.

Es así que, debido a los hechos comentados anteriormente, se han realizado varios análisis para determinar cuál es la razón de la falencia en estos procesos de metalización; como lo explican Fang et al. (2010), uno de los puntos más importante es que, para seguir la trayectoria necesaria la antorcha de metalización debe cambiar rápidamente de posición debido a las geometrías irregulares del sustrato provocando un cambio en la velocidad programada para el robot; como se muestra en la Figura 1, este caso está dado por la inercia generada por la antorcha y por el rápido cambio entre trayectorias lineales y curvas.



Figura 1 Trayectoria angular muy extensa. (Fang et al, 2010)

Existen varias formas de optimizar trayectorias para realizar recubrimientos metálicos como lo demuestran Kout & Müller (2009), dentro de su investigación, ellos han analizado superficies con diferentes geometrías para realizar recubrimientos generando una optimización en la trayectoria mediante el análisis de diferentes modelos matemáticos.

Uno de estos modelos matemáticos y el más representativo es el que se muestra en la investigación de Duncan et al. (2005), donde como se muestra en la Figura 2, se debe generar una trayectoria de forma escalonada que tenga la separación necesaria dependiendo del haz de deposición que se tenga, además debe salir y entrar de la sección donde se realiza el recubrimiento para mantener una velocidad y aceleración constante dentro de esta sección.

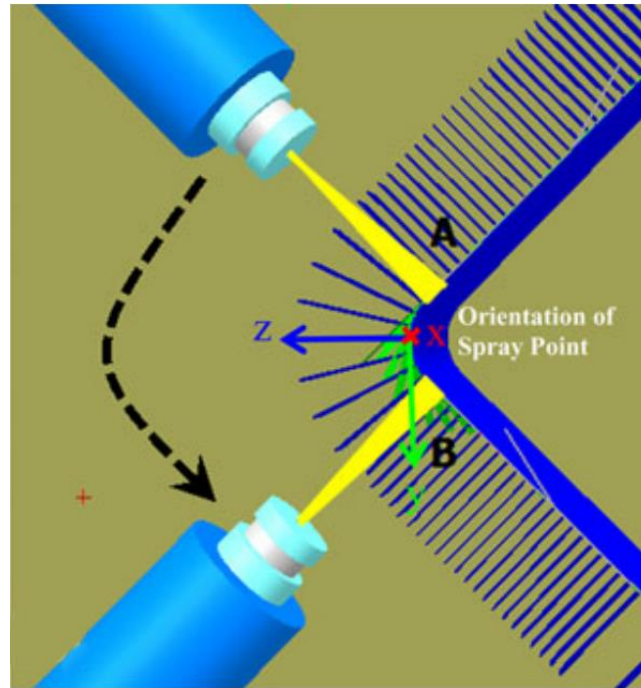

Figura 2 Trayectoria del proceso de metalización

El modelo de Duncan et al. (2005) se ha implementado en el estudio de Kout & Müller (2009) y como se muestra en la Tabla 1, los errores porcentuales en el espesor de los recubrimientos por un proceso de metalización óptimo son muy bajos inclusive para superficies complicadas como el interior de cilindros y esferas.

Tabla 1 Errores de recubrimiento para varias formas de superficie.

Superficie	Error promedio del recubrimiento [%]	Máximo error del recubrimiento [%]
Plana	0.025	0.07
Cilindro	0.035	0.13
Esfera	0.036	0.10
Interior del Cilindro	0.043	0.11
Interior de la Esfera	0.043	0.14

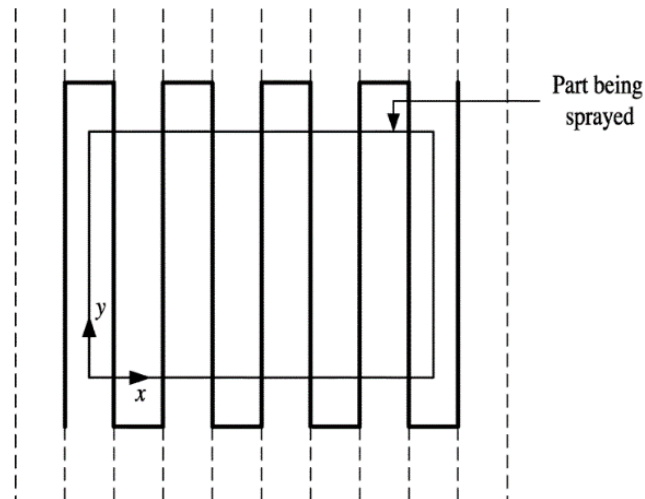
Extraído de: https://www.researchgate.net/publication/220291427_Parameter_optimization_for_spray_coating

Es así como, alrededor del mundo se realiza la remanufactura de los álabes de turbinas Pelton, comúnmente mediante procesos manuales y con menor frecuencia de manera automatizada. Lo que se busca en este estudio es poder generar una trayectoria mediante un

brazo robótico que ayude a obtener un proceso de recubrimiento, mediante metalización, homogéneo para estos álabes.

Esta investigación busca como objetivo principal el generar una trayectoria que pueda tener los parámetros adecuados para generar un recubrimiento mediante metalización a álabes de turbinas Pelton y ayudar a la seguridad de quienes realizan este tipo de procesos. Esto puede ser útil para que las empresas de remanufactura nacionales tanto privadas como públicas puedan ofrecer un servicio más especializado a las distintas hidroeléctricas que se encuentran en el país y que trabajan con este tipo de turbinas. La importancia de esta investigación radica, entonces, en el desarrollo que pueden tener los procesos de metalización automatizados por medio de brazos robóticos en distintos tipos de álabes y más allá, en cualquier objeto que posea superficies irregulares.

Dentro de esta investigación, se espera estudiar y generar una trayectoria para realizar recubrimientos mediante metalización en un modelo de álabe de turbina Pelton a escala 1:5. Asimismo, se desea determinar y analizar el espesor del recubrimiento depositado en este modelo. Siguiendo con el estudio, se medirá la temperatura en el momento de la deposición del recubrimiento para analizarla y que esto sirva de guía para poder generar una estimación de esfuerzos residuales mediante una simulación de elementos finitos en el recubrimiento. Una vez realizados estos análisis se podrá llegar a la conclusión de cual es una trayectoria aceptable para realizar estos procesos.

MÉTODOS Y MATERIALES

Generación del álabe de una turbina Pelton

Para poder realizar el modelo del álabe se comenzó obteniendo el modelo CAD del rodete de una turbina Pelton como se muestra a continuación en la Figura 3.



Figura 3 CAD del Rodete de una Turbina Pelton.

Este CAD se pudo obtener gracias a contactos con la Hidroeléctrica Coca Codo Sinclair situada en Napo-Ecuador. A este CAD se lo separó en partes gracias al Software Inventor de Autodesk para así poder obtener como se muestra en la Figura 4, un par de álabes de la turbina.



Figura 4 CAD del Alabe de una Turbina Pelton.

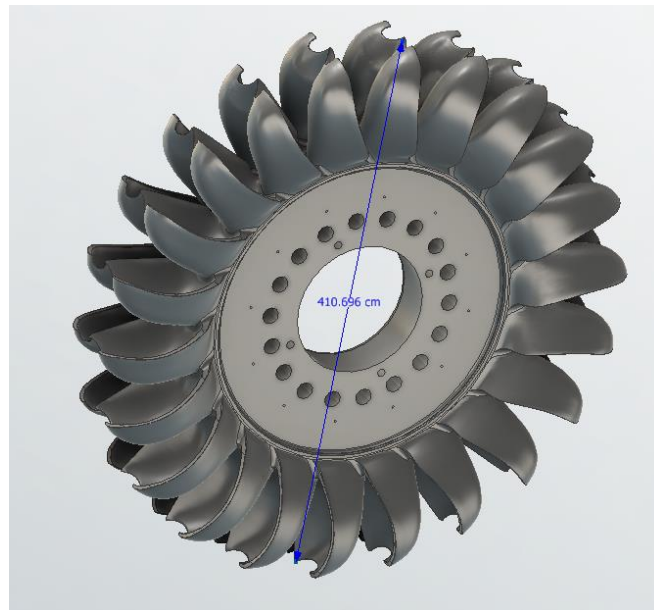

Figura 5 Impresión en 3D del álabe en escala 1:5

Una vez que se obtuvo el CAD del par de álabes se los redujo con una escala de 1:5 para así poder realizar la impresión en 3D con la ayuda del Software Cura, como se muestra en la Figura 5.

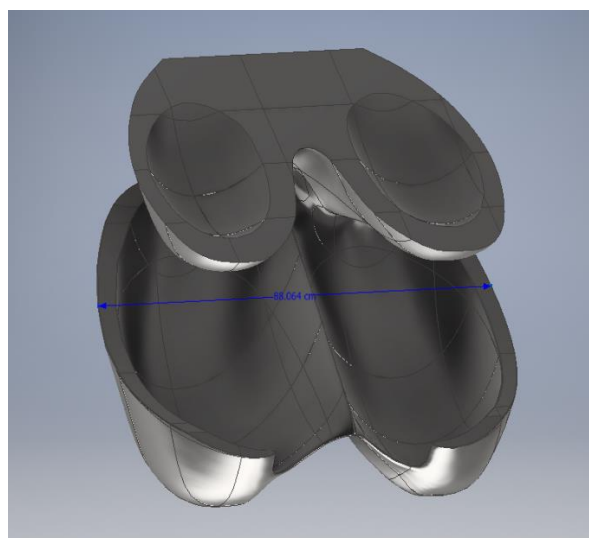

Figura 6 Plantilla en 2D del álabe en escala 1:5

Por otro lado, se generó una plantilla en 2D en papel como se muestra en la Figura 6, esta se la realizó tomando en cuenta la geometría del modelo en 3D y siguiendo el patrón de

cascarones, realizando el mínimo número de cortes para que las uniones en el modelo final sean mínimas.

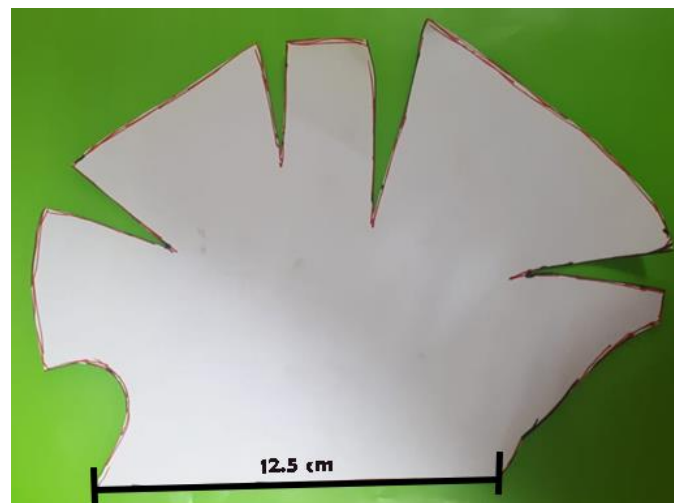

Figura 7 Modelo a escala 1:5 del álabe en acero de 0.5mm de espesor

Una vez obtenida la plantilla en 2D se realizó el modelo final como se muestra en la Figura 7, recortando una plancha de acero de 0.5 mm de espesor, este modelo fue unido mediante soldadura de punto y aplanado sus uniones para tratar de obtener una superficie uniforme.

Sistema de medición de Temperatura

Para el sistema de medición de temperatura se utilizó 10 termocuplas colocadas a lo largo del alabe en los puntos seleccionados como se muestran en la Figura 8, además en la Figura 9, se muestra el recubrimiento realizado a las termocuplas con cemento refractario para que estas tengan la protección adecuada a las altas temperaturas; para poder realizar este sistema se utilizó 10 módulos Max6675, 10 termocuplas y un Arduino MEGA como se muestra en la Figura 10 & 11. Con este sistema se calculó el gradiente de temperatura a lo largo de nuestro álabe a medida que se realiza el recubrimiento metálico utilizando el display interno del Software Arduino y procesando los datos con el Software Excel.

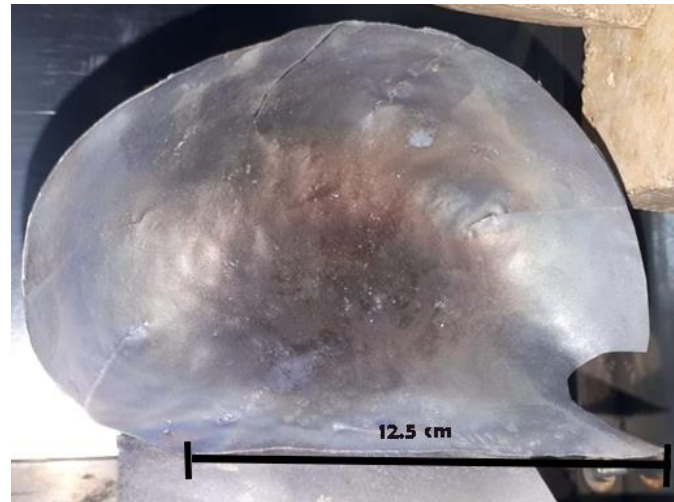

Figura 8 Distribución en el Alabe de las termocuplas



Figura 9 Recubrimiento para protección de termocuplas

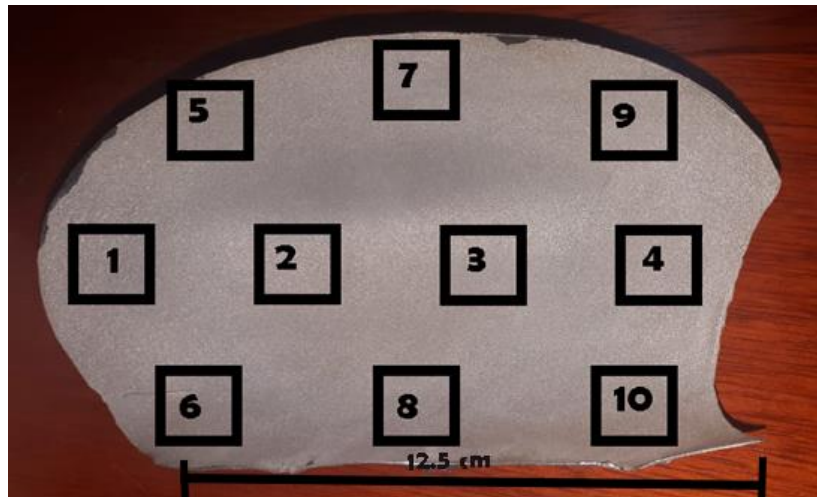

Figura 10 Circuito generado para la medición de temperatura



Figura 11 Diagrama del circuito para la medición de temperatura

Metalización en el modelo del álabe

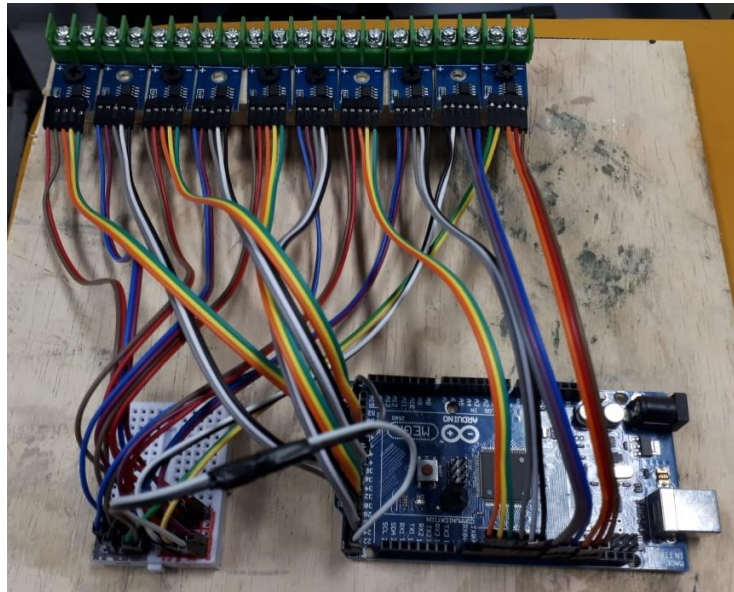
Para realizar el recubrimiento metálico en el álabe se utilizó como se muestra en la Figura 12, una Torcha de termorociado **Oerlikon Metco 5P-II** anclada a un brazo robótico **KUKA KR20**. Por otro lado, el material de metalización que se utilizó es el polvo Eutectic-Castolin 11496, este tiene una base de Ni con más del 27% de composición de Ni y también está compuesto por Cr, B, Si, Fe & C.

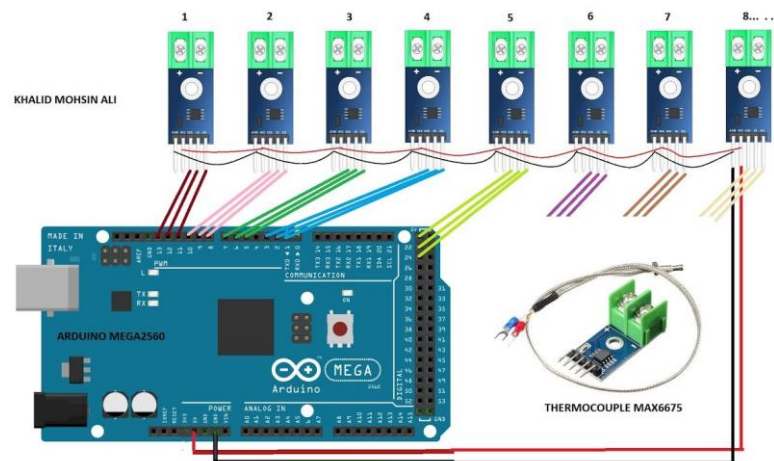

Figura 12 Torcha de termorociado Oerlikon Metco 5P-II anclada a un brazo robótico KUKA KR20

Para la programación de la trayectoria de los álabes se realizó una serie de procedimientos para preparar adecuadamente el brazo robótico, estos son:

- Calibración de la herramienta de trabajo (Torcha de Termorociado).
- Calibración de la mesa de trabajo.
- Calibración de la herramienta de reemplazo (Herramienta utilizada en sustitución de la Torcha de Termorociado debido a que el modelo en 3D tiene dimensiones que comprometen el tamaño de la herramienta principal).
- Preparación punto-a-punto de la trayectoria de la superficie de los álabes.

Calibración de la herramienta de trabajo (Torcha de Termorociado).

Para la calibración de la herramienta de trabajo o TCP se realizó el **Método XYZ 4 Puntos**, el cual se puede observar en la Figura 13 y es descrito a continuación:



Figura 13 Método de calibración de herramienta de trabajo XYZ 4-Puntos.

Extraído de: <https://www.kuka.com/es-es/productos-servicios/sistemas-de-robot/robot-industrial/kr-cybertech>

1. Seleccionar en el menú principal **Puesta en servicio > Medir > Herramienta > XYZ de 4 puntos.**
2. Indicar un número y un nombre para la herramienta que se quiere medir. Confirmar pulsando **Continuar.**
3. Acercar un punto de referencia con el TCP. Pulsar en **Medir.** Responder **Sí** a la pregunta de seguridad.
4. Con el TCP desplazarse al punto de referencia desde otra dirección. Pulsar en **Medir.** Responder **Sí** a la pregunta de seguridad.
5. Repetir dos veces el paso 4.
6. Confirmar pulsando **Continuar.**

Calibración de la mesa de trabajo

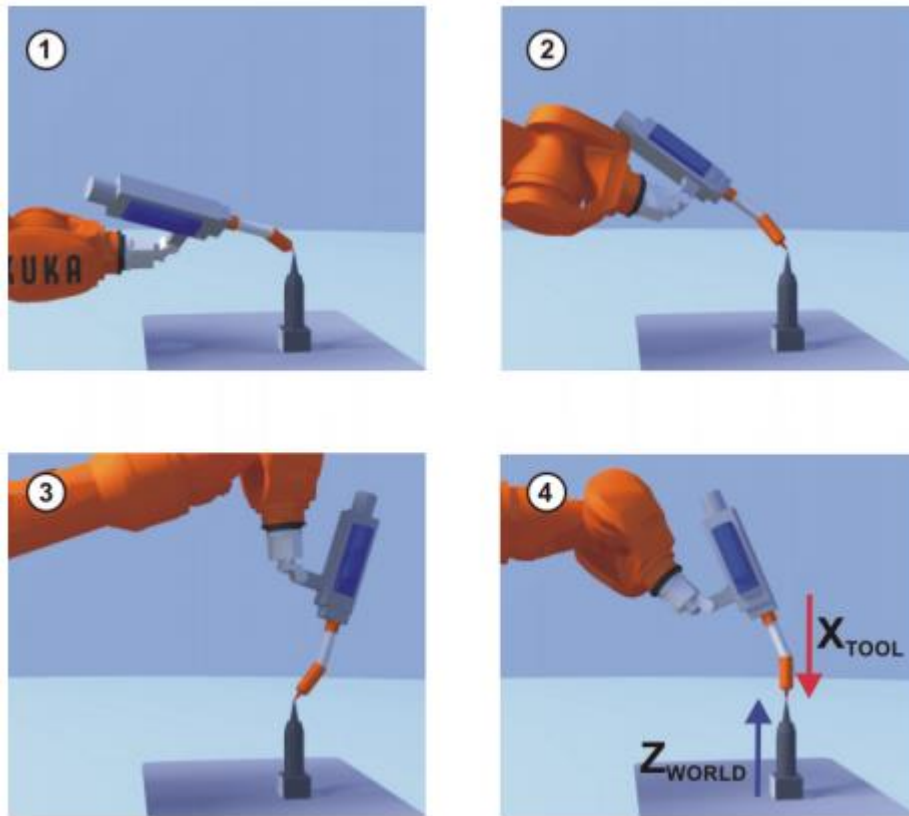
Para la calibración de la mesa de trabajo se realizó el **Método de los 3 puntos**, el cual se puede observar en la Figura 14 y es descrito a continuación:



Figura 14 Método de calibración de mesa de trabajo de los 3 puntos.

Extraído de: <https://www.kuka.com/es-es/productos-servicios/sistemas-de-robot/robot-industrial/kr-cybertech>

1. En el menú principal, seleccionar **Puesta en servicio > Medir > Base > 3 puntos**.
2. Introducir un número y un nombre para la base. Confirmar pulsando **Continuar**.
3. Indicar el número de la herramienta montada. Confirmar pulsando **Continuar**.

4. Con el TCP mover el robot a la nueva base. Pulsar en **Medir**. Responder **Sí** a la pregunta de seguridad.
5. Con el TCP desplazar el robot a un punto del eje X positivo de la nueva base. Pulsar en **Medir**. Responder **Sí** a la pregunta de seguridad.
6. Con el TCP desplazar el robot a un punto del plano XY con valor Y positivo. Pulsar en **Medir**. Responder **Sí** a la pregunta de seguridad.
7. Pulsar **Guardar**.

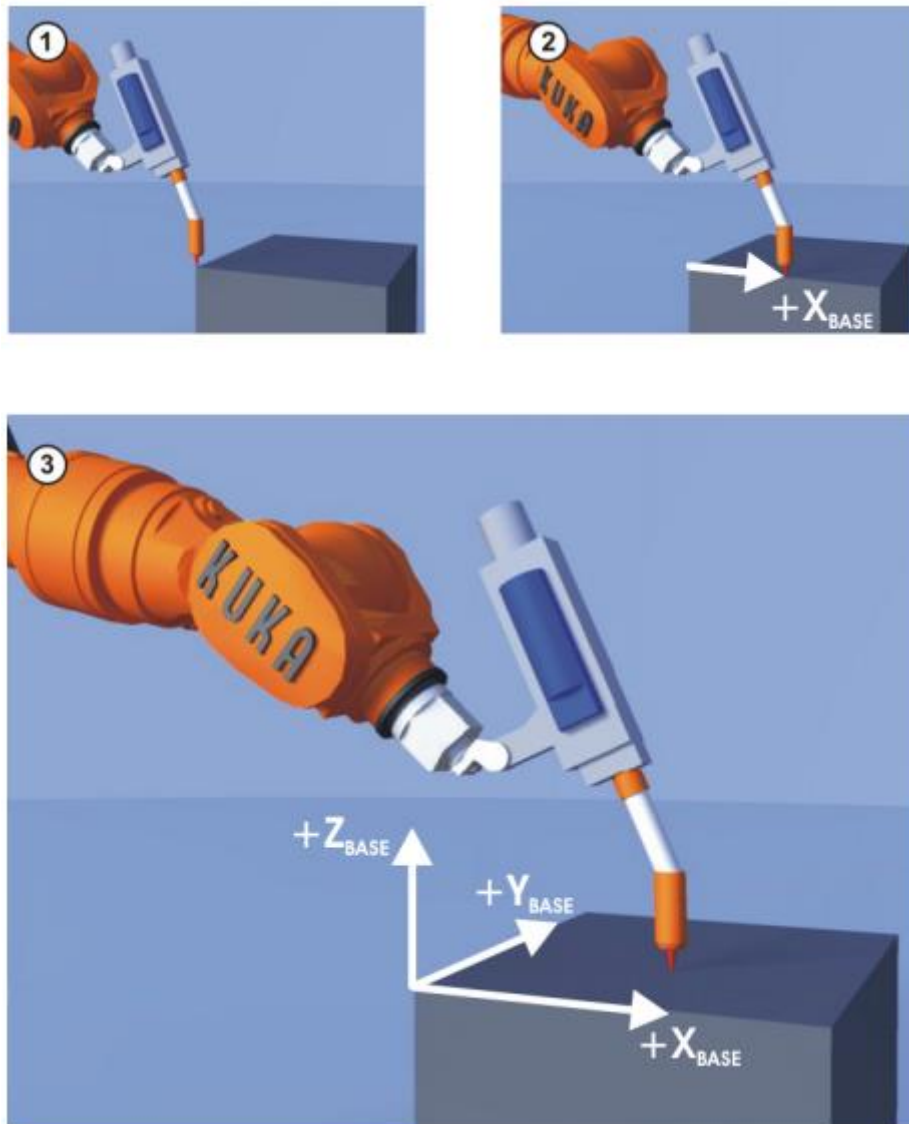
Calibración de la herramienta de reemplazo

1. Realizar una marca en un lugar apartado de la mesa de trabajo.
2. Con el TCP desplazar el robot hasta la marca de la mesa de trabajo, de manera que el TCP quede completamente cerca de la mesa de trabajo.
3. Retirar el TCP del soporte del robot.
4. Colocar la herramienta de reemplazo de manera que la punta de esta se sitúe exactamente sobre la marca realizada en el paso **1** (Figura 15).



Figura 15 Reemplazo del TCP.

Preparación punto-a-punto de la trayectoria de la superficie de los álabes

Previo a la realización de la trayectoria, se debe crear un nuevo programa de la siguiente manera y guiándose en la Figura 16:

1. En la **estructura de directorios**, marcar la carpeta en que debe crearse el programa, p. ej. la carpeta **Programa**. Pulsar **Nuevo**.
2. Introducir un nombre para el programa y confirmar pulsando en **OK**.

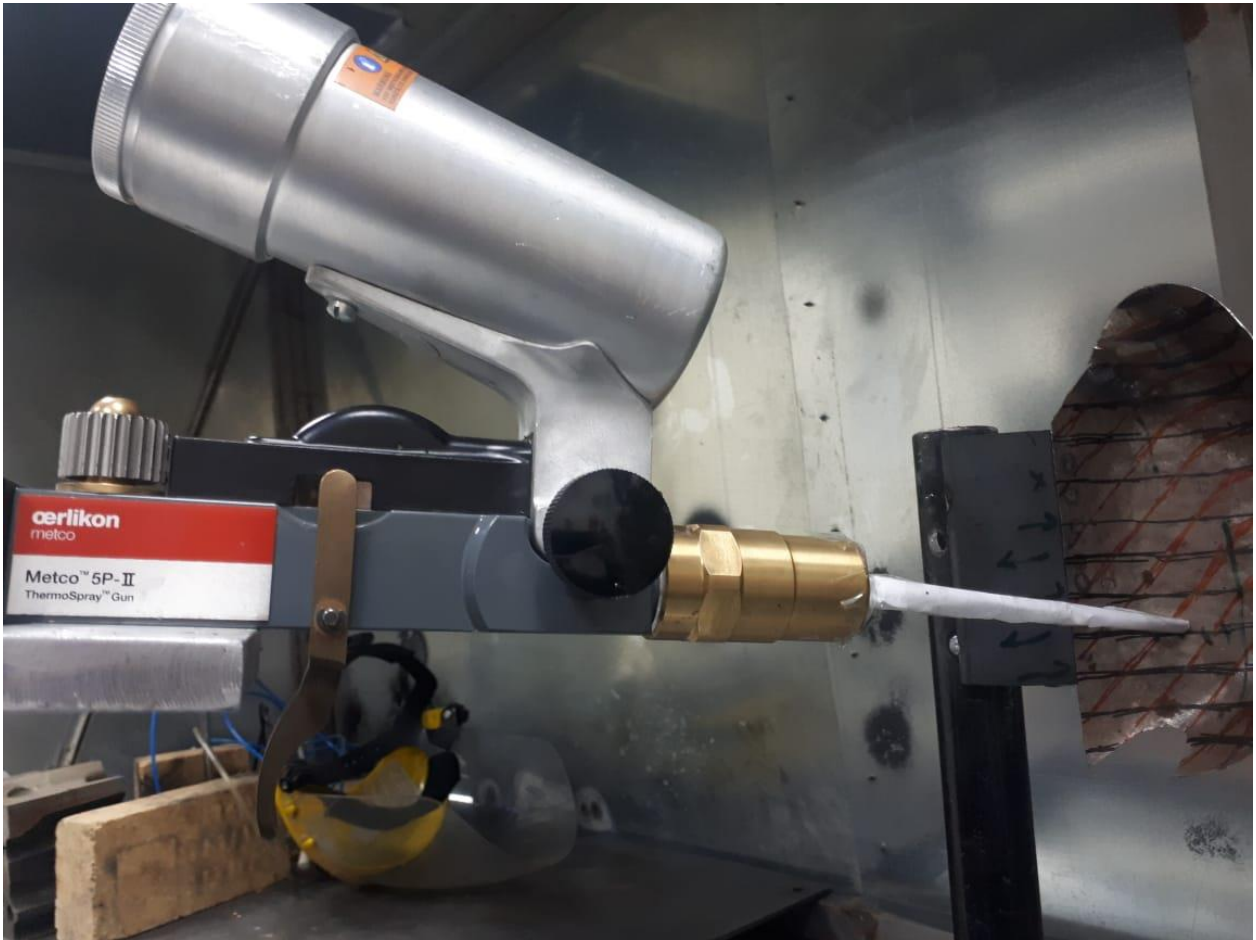

Figura 16 Navegador

Extraído de: <https://www.kuka.com/es-es/productos-servicios/sistemas-de-robot/robot-industrial/kr-cybertech>

- 1) Encabezamiento
- 2) Estructura de directorios
- 3) Lista de Ficheros
- 4) Línea de estado.

Una vez creado el nuevo programa se procede a realizar la programación punto-a-punto de la trayectoria requerida en una pantalla de programación como la que se muestra en la Figura 17.

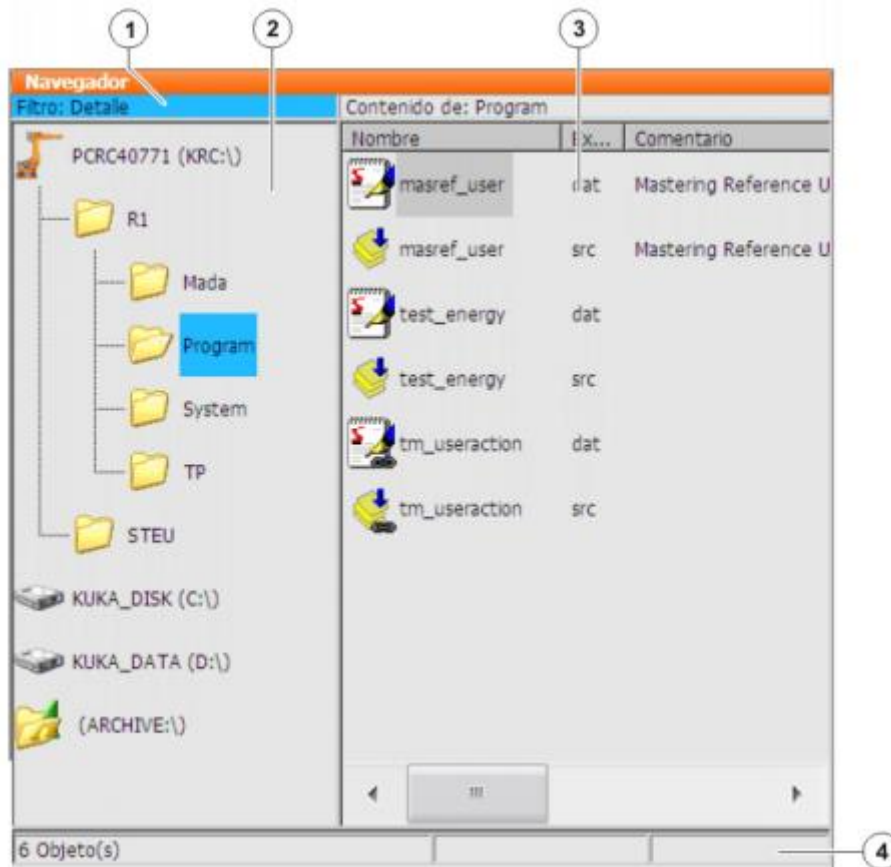

Figura 17 Pantalla del programa.

Extraído de: <https://www.kuka.com/es-es/productos-servicios/sistemas-de-robot/robot-industrial/kr-cybertech>

- 1) Puntero de paso
- 2) Cursor
- 3) Ruta del programa y nombre del fichero
- 4) Posición del cursor en el programa
- 5) Este símbolo indica que el programa está seleccionado.

Una vez reconocida la pantalla de programación se procede a preparar los puntos para la trayectoria de los álabes de la siguiente manera:

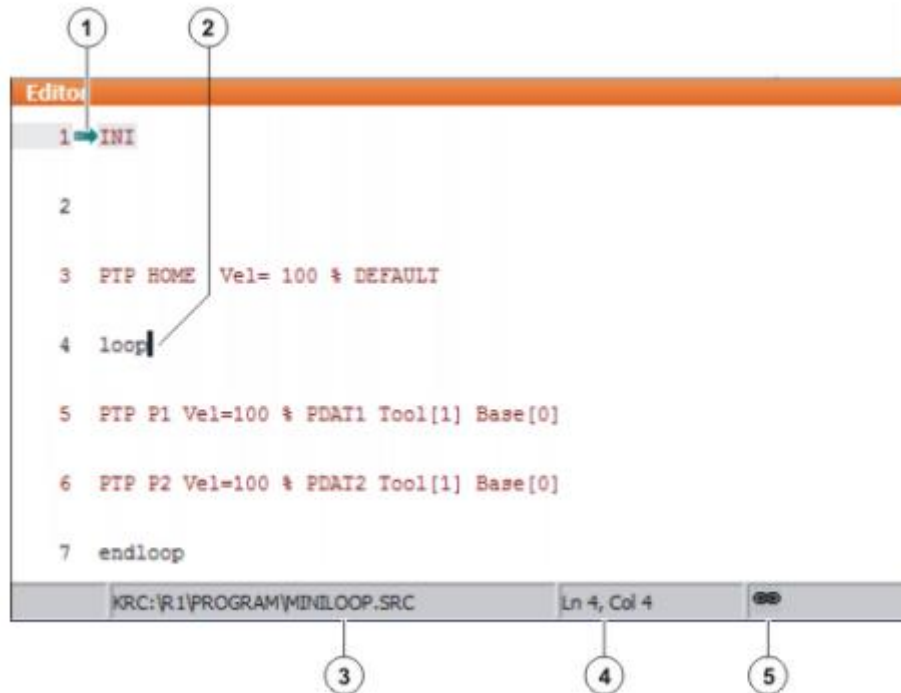
1. Borrar todas las líneas de programación de la pantalla del programa a excepción de “INI” y “END”.
2. Mover el TCP a la posición que se programará por aprendizaje como punto de destino.
3. Colocar el cursor en la línea detrás de la cual se insertará la instrucción de movimiento.
4. Seleccionar la secuencia de menú **Instrucciones > Movimiento > PTP**.
5. Guardar pulsando **Instrucción OK**.

6. Desplazar el TCP a la posición que se programará por aprendizaje como punto auxiliar.
7. Colocar el cursor en la línea detrás de la cual se insertará la instrucción de movimiento.
8. Seleccionar la secuencia de menú **Instrucciones > Movimiento > LIN**.
9. Seleccionar la opción **CONT** en la línea de comandos (Figura 18).
10. Guardar pulsando **Instrucción OK**.
11. Desplazar el TCP a la siguiente posición de la trayectoria de los álabes y repetir los pasos del **7** al **10**.



Figura 18 Línea de comandos.

Trayectorias generadas para los recubrimientos

Durante el análisis de nuestro caso de estudio se ha llegado a obtener dos diferentes tipos de trayectorias para efectuar la metalización de nuestro modelo a escala 1:5 del álabe de una turbina Pelton, estas dos trayectorias se representan en la Figura 19 y 20 a continuación:



Figura 19 Trayectoria A



Figura 20 Trayectoria B

Puesto que, para obtener recubrimientos con espesores entre 30 y 40 micras por cada pasada, la velocidad de avance del recubrimiento para este caso fue de 1 m/s, en la Trayectoria A se realizó 6 pasadas, comenzando por un lado externo del álabe hacia el centro de este y después comenzando una nueva pasada por el lado opuesto de igual manera hacia el centro completando el ciclo de recubrimiento; en el caso de la Trayectoria B en la que se realizó 12 pasadas se realizó el recubrimiento comenzando desde la parte superior del álabe y siguiendo de forma escalonada hasta la parte inferior de este.

Medición del espesor del recubrimiento

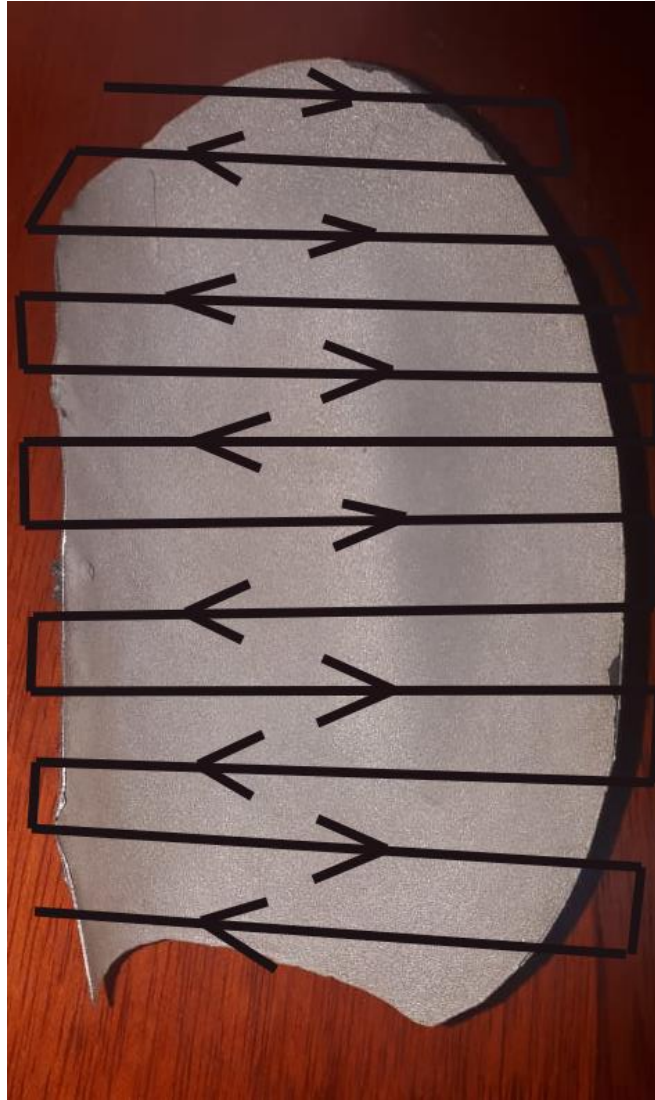

Figura 21 Sectores donde se realizaron las mediciones de espesor del recubrimiento (A y B).

Para la comprobación de que el recubrimiento es uniforme a lo largo de todo el álabe se utilizó un medidor de espesor de revestimientos Elcometer 456 (Figura 22), con este se midió en diferentes posiciones como se muestra en la Figura 21, con estas mediciones se podrá comprobar que los parámetros de recubrimiento son los correctos. Este medidor utiliza el principio de inducción electromagnética que, se emplea para revestimientos no magnéticos sobre sustratos magnéticos como el acero. Por otro lado, también utiliza el principio de corriente de Foucault que, se utiliza para revestimientos no conductivos en sustratos de metales no ferrosos.



Figura 22 Medidor de Espesor de Revestimientos Elcometer 456

Simulación de esfuerzos residuales

Para la realización de la simulación de esfuerzos residuales se utilizó el Software: **Abaqus by Dassault Systèmes**, en el cual como se muestra en la Figura 23, se realizó un CAD del álabe y se distribuyó los nodos de forma que, en los sectores que se muestran en la Figura 23 se asignaran las temperaturas medidas mediante las termocuplas y se las llevará hasta temperatura ambiente. Por otro lado, se utilizó los datos de la Tabla 2, como parámetros para realizar la simulación de esfuerzos residuales.



Figura 23 CAD en Abaqus para la simulación de esfuerzos residuales con la localización de los diferentes nodos con sus diferentes temperaturas.

Tabla 2 Entradas para la simulación de esfuerzos residuales.

Material	Modulo de Young [GPa]	Coefficiente de Poisson	Coefficiente de Expansion [°C]
Acero	200	0.3	1.30E-05
Niquel	171	0.21	1.60E-06

DISCUSIÓN Y RESULTADOS

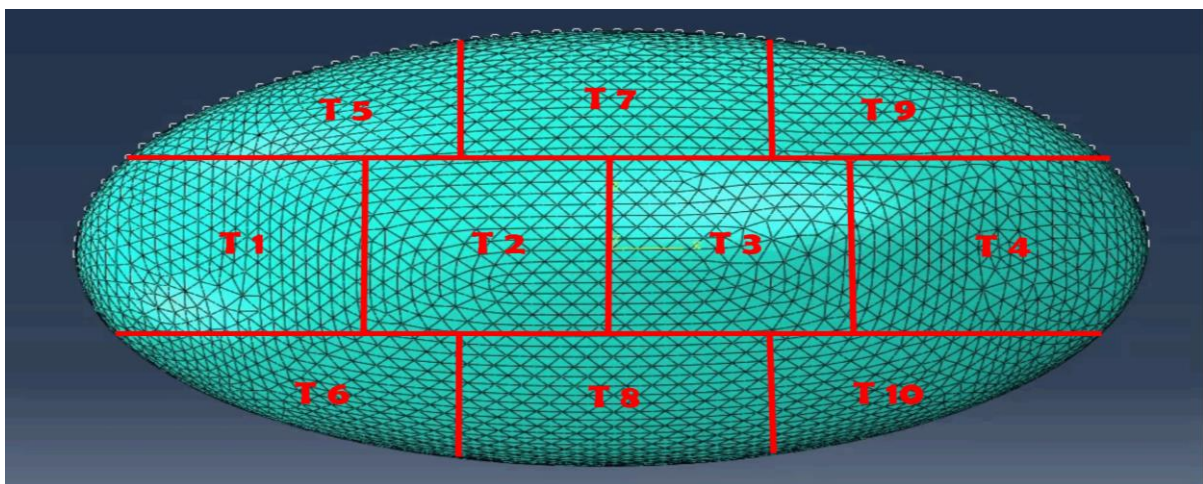
Resultados

Trayectoria A

Después de que se realizó el análisis de espesores del recubrimiento en el álabe para el caso de la Trayectoria A (Figura 19), se pudo obtener un espesor promedio de **192.89 micras** dando como resultado para cada pasada un espesor de **32.15 micras** de espesor de recubrimiento.

De la Figura 24 podemos concluir que las zonas centrales del álabe poseen un recubrimiento homogéneo, por otro lado, la zona A posee un espesor promedio de **80 micras** el cual se da debido a que la trayectoria realizada no está lo suficientemente cerca del borde. De igual manera en la zona D y F en los sectores del 1 al 6 podemos ver una acumulación de recubrimiento debido a que dentro de la trayectoria generada las pasadas realizadas en estas zonas y sectores se acumularon debido a la geometría del álabe.



Figura 24 Espesores del Recubrimiento a lo largo del Alabe "A"

Como podemos observar en la Figura 25, las zonas externas, es decir, donde se encuentran las termocuplas 5, 6, 7, 8, 9 y 10 son aquellas zonas que estuvieron menos afectadas por la temperatura llegando a temperaturas máximas de **380 grados Centígrados**, por otro lado la zona central donde se encontraban las termocuplas 1, 2, 3 y 4 son las zonas que más afectación tuvieron por el calor llegando a temperaturas de hasta **550 grados Centígrados**; esto nos da a entender que debido a que la Trayectoria A se dividió en dos pasos que siempre terminaban en la zona central del álabe, esta zona iba acumulando el calor y por eso su temperatura fue mayor que en las zonas externas.

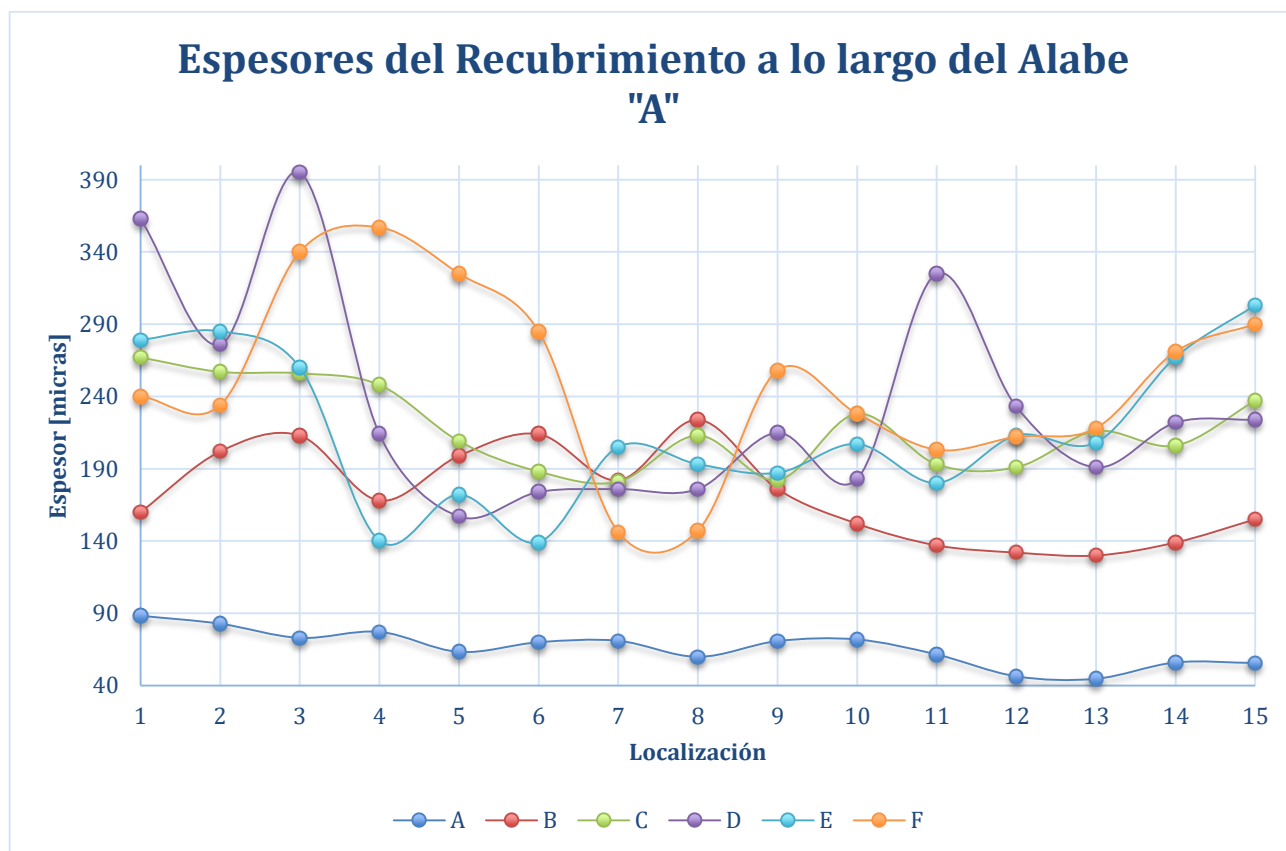

Figura 25 Distribución de la Temperatura del Sustrato durante el Recubrimiento del Alabe "A"

En la Figura 26 podemos observar, que el enfriamiento del álabe después de recibir el recubrimiento se comportó de manera normal, disminuyendo su temperatura de forma constante, esto se pudo lograr ya que el laboratorio donde se realizó este proceso no tuvo cambios abruptos de temperatura ni corrientes externas de aire que pudieran acelerar el proceso de enfriamiento.

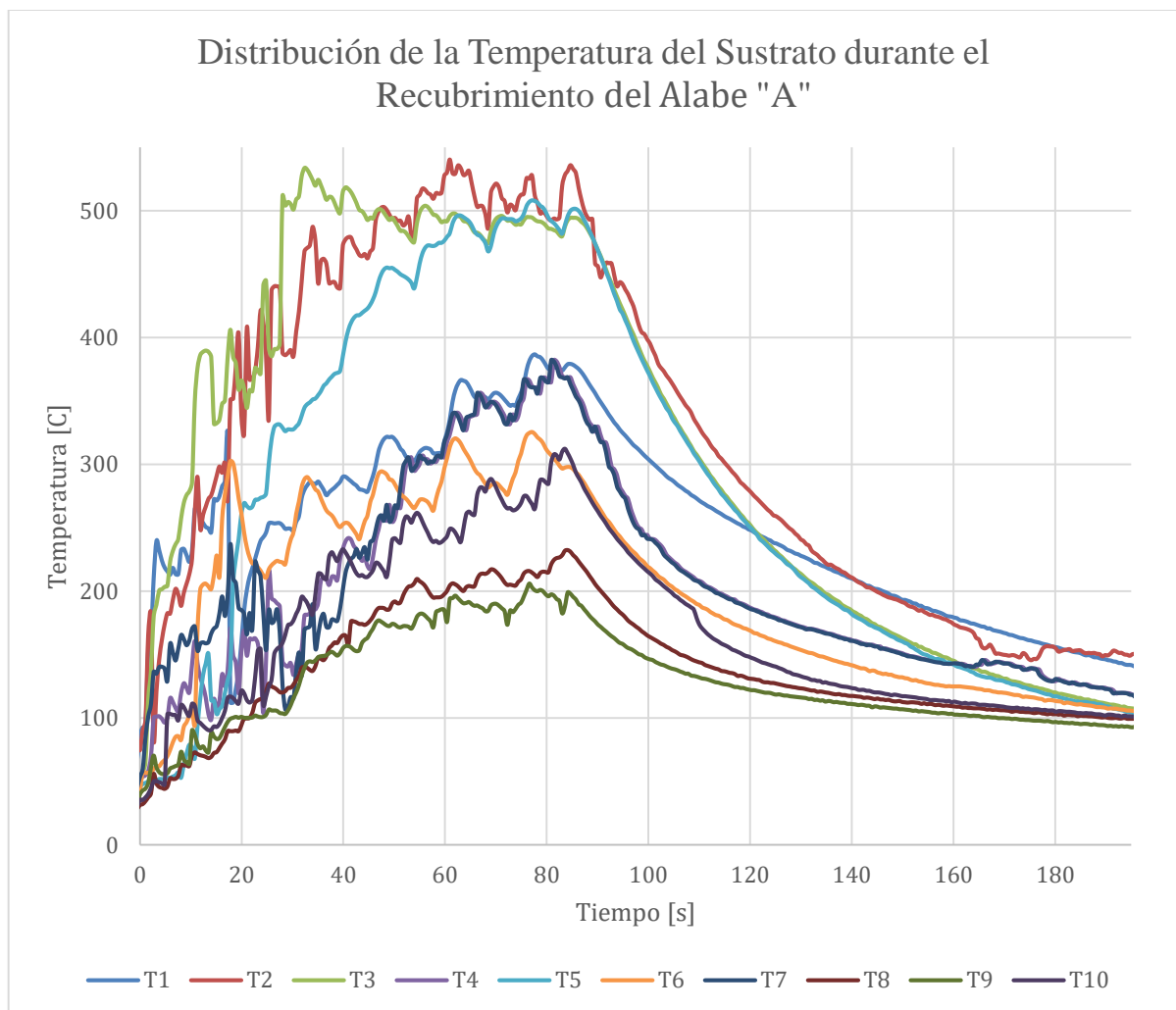

Figura 26 Distribución de la Temperatura del Sustrato durante el Enfriamiento del Alabe "A"

Una vez medidas las temperaturas en cada sector de nuestro modelo se pudo generar la simulación para encontrar los esfuerzos residuales después del proceso de metalización, con esta simulación se pudo observar en la Figura 27, que, los esfuerzos residuales generados en S11 son de **112 [MPa]**, los mayores esfuerzos se encuentran situados en las zonas externas de nuestro modelo donde la superficie del material tiene un cambio de dirección. De igual manera,

se observa en la Figura 28, que los esfuerzos residuales en S22 son de **186 [MPa]**, los mayores esfuerzos se encuentran en la zona central de nuestro modelo donde comienza a tener un cambio en la dirección de la superficie. Finalmente, como se observa en la Figura 29, los esfuerzos residuales en S33 son de **113 [MPa]**, estos están situados en las paredes del modelo donde la superficie del material cambia completamente. Por otro lado, podemos observar que existen esfuerzos cortantes como se muestran en la Figura 30, 31 y 32, donde los esfuerzos llegan a **118, 133 y 146 [MPa]** respectivamente en los planos S12, S13 y S23. Asimismo, en la Figura 33, podemos observar los esfuerzos mediante VonMises en los que el esfuerzo mayor es de **340 [MPa]**, todo este análisis muestra que no existe fallo en el material debido a que estos valores no superan el del UTS del Níquel.

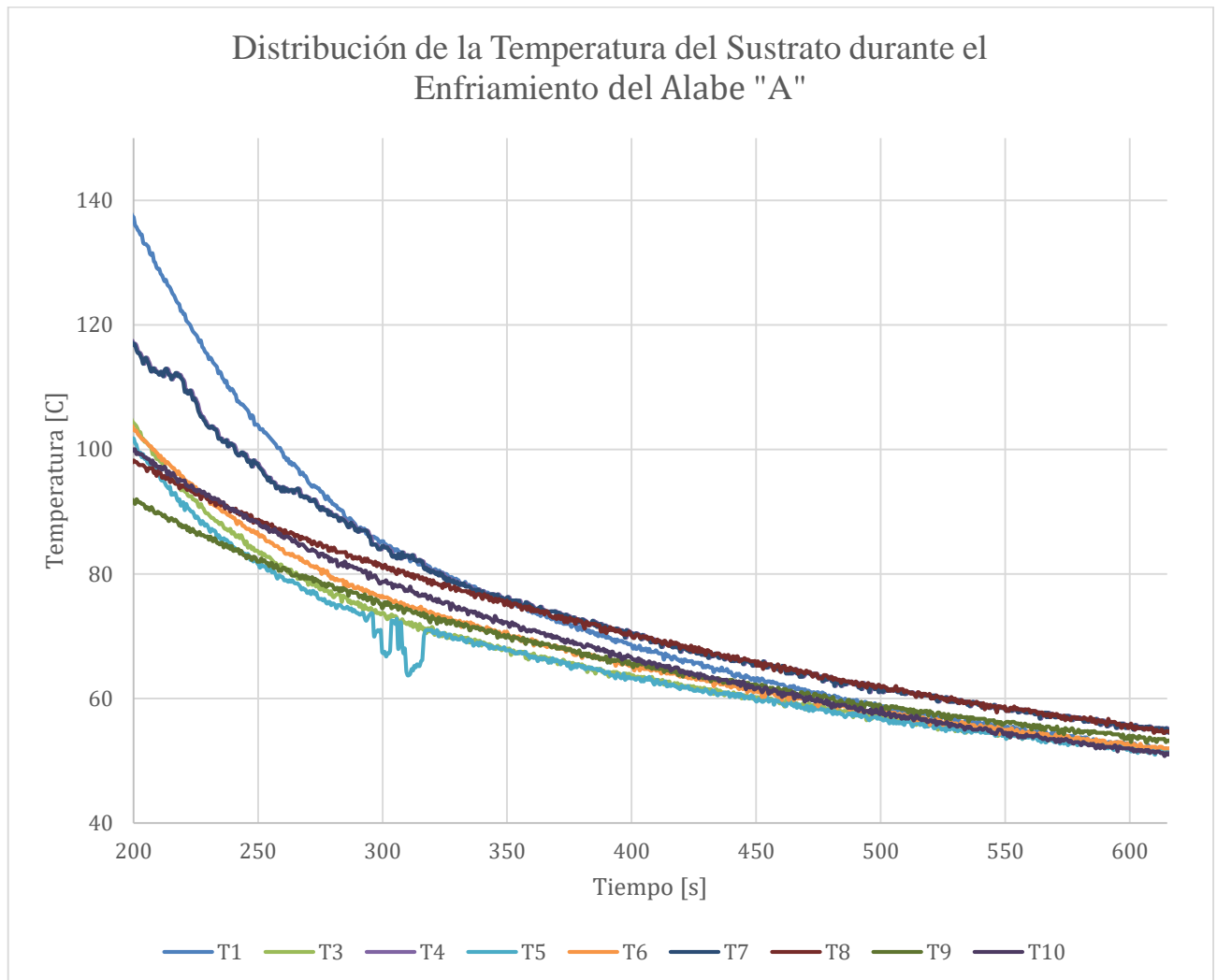

Figura 27 Simulación de Esfuerzos Residuales para la Trayectoria A (Esfuerzos en S11)



Figura 28 Simulación de Esfuerzos Residuales para la Trayectoria A (Esfuerzos en S22)

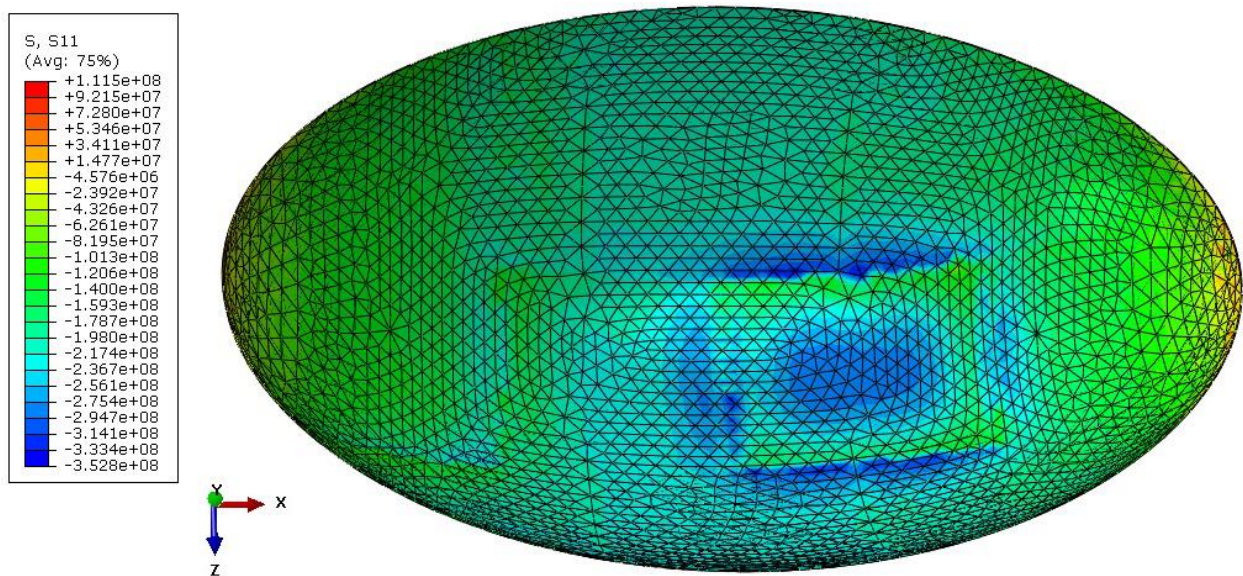

Figura 29 Simulación de Esfuerzos Residuales para la Trayectoria A (Esfuerzos en S33)

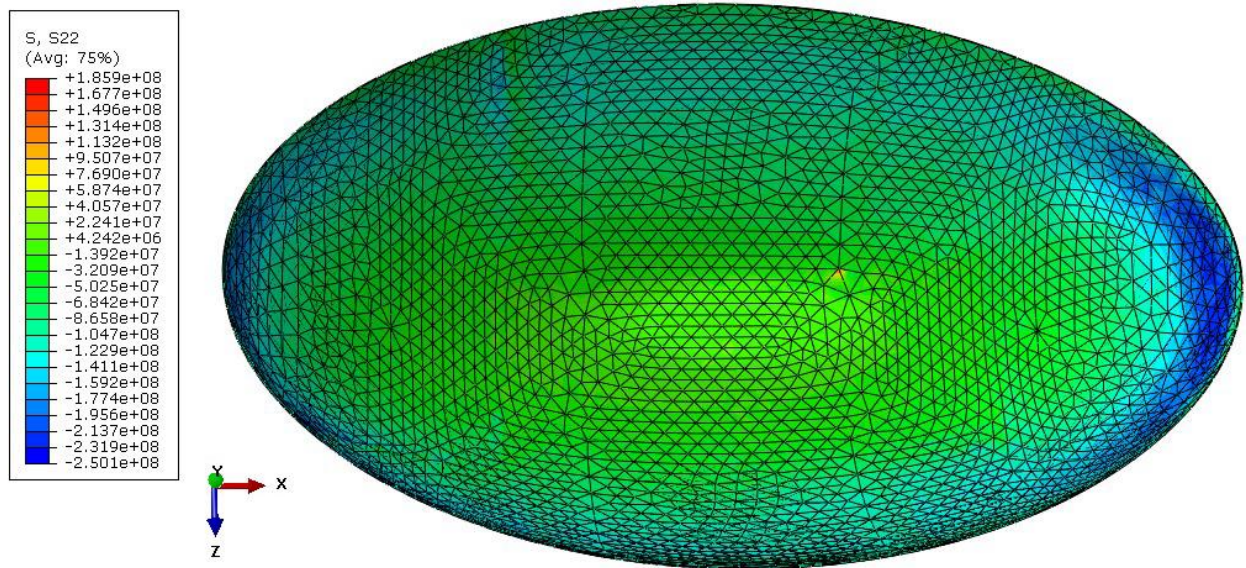

Figura 30 Simulación de Esfuerzos Residuales para la Trayectoria A (Esfuerzos en S12)

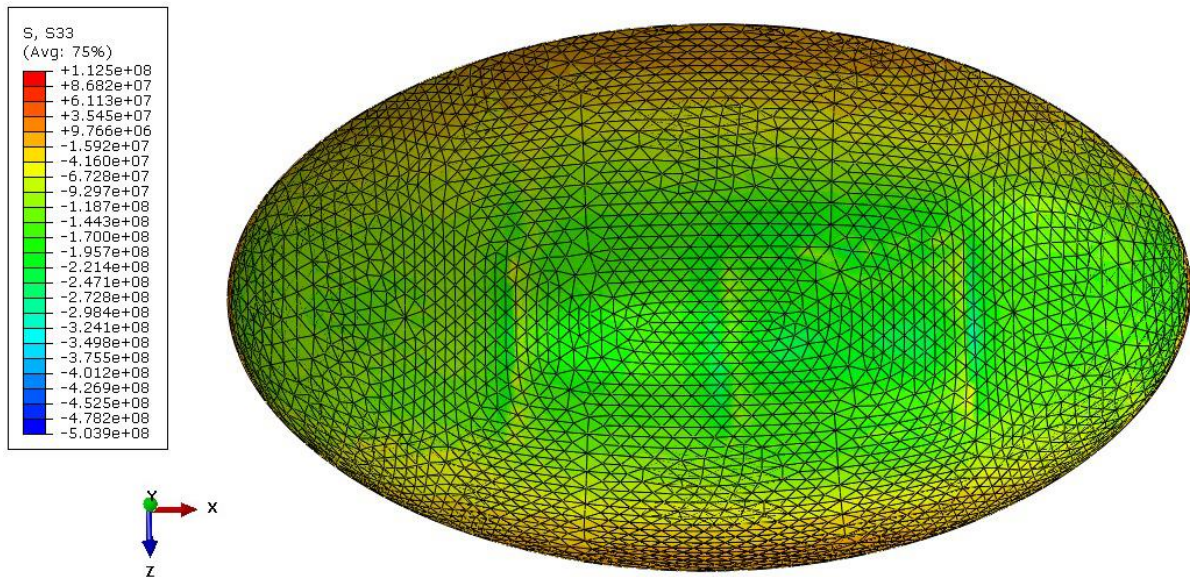

Figura 31 Simulación de Esfuerzos Residuales para la Trayectoria A (Esfuerzos en S13)

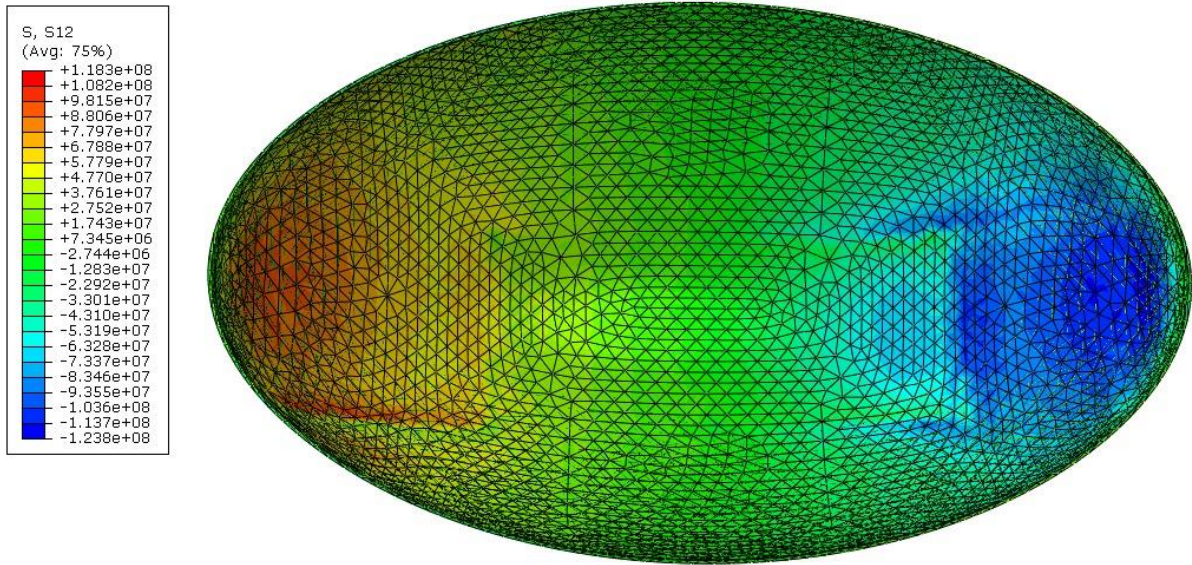

Figura 32 Simulación de Esfuerzos Residuales para la Trayectoria A (Esfuerzos en S23)

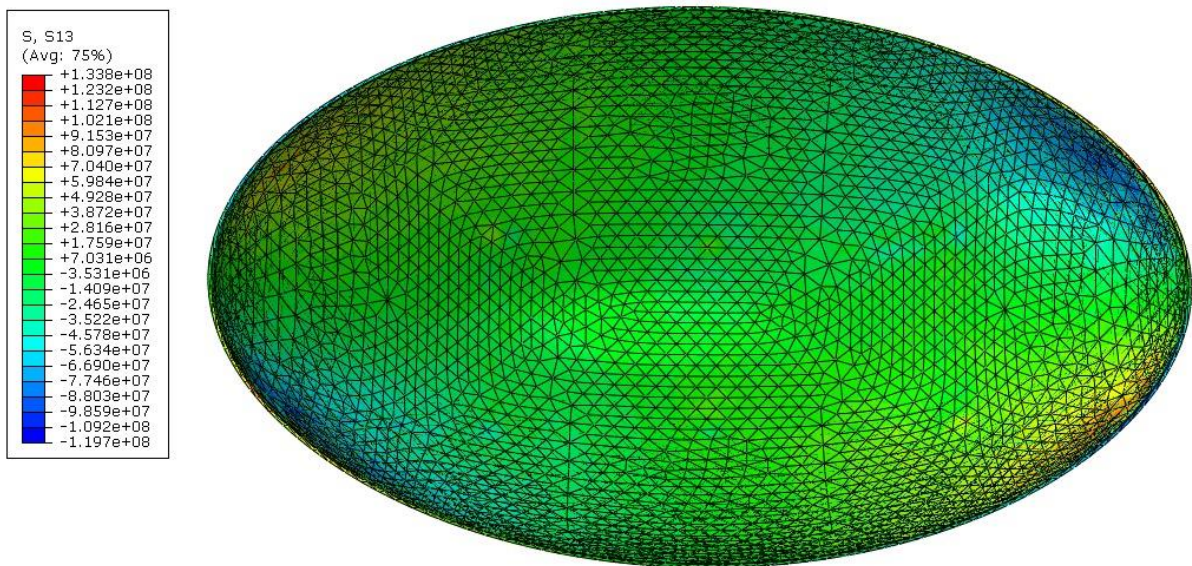

Figura 33 Simulación de Esfuerzos Residuales para la Trayectoria A (Esfuerzos de VonMises)

Trayectoria B

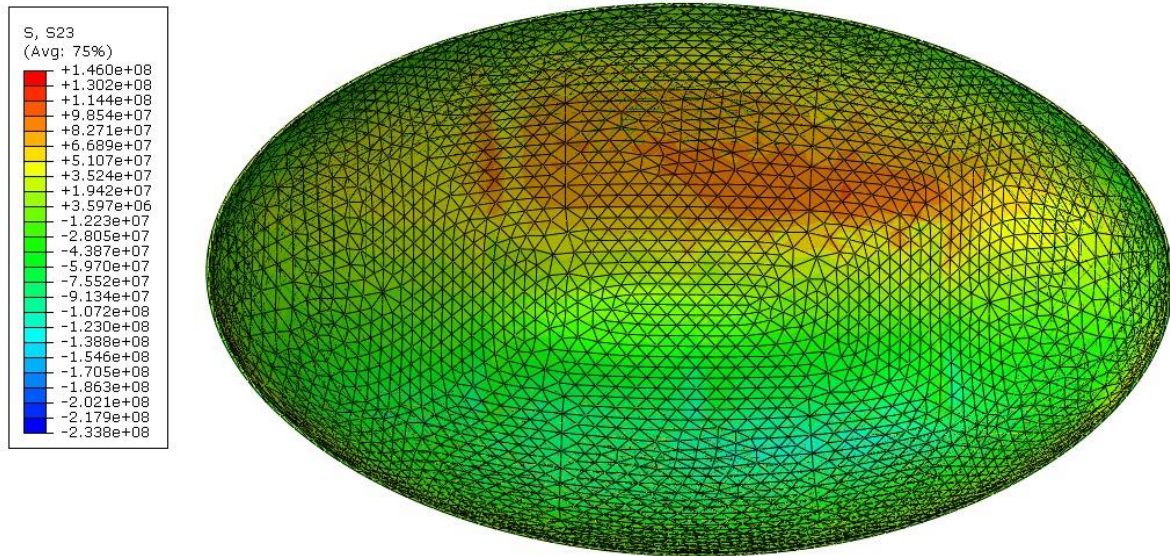
Después de realizar el análisis de espesores del recubrimiento en el álabe para el caso de la Trayectoria B (Figura 20), se pudo obtener un espesor promedio de **592.21 micras** dando como resultado para cada pasada un espesor de **49.35 micras** de espesor de recubrimiento.

En la Figura 34, podemos observar que en las zonas C, D, E y F, y en los sectores del 7 al 12 los espesores del recubrimiento son muy altos debido a la geometría del álabe que es muy cerrada y por lo cual la trayectoria generada se encuentra muy concentrada en esas zonas.

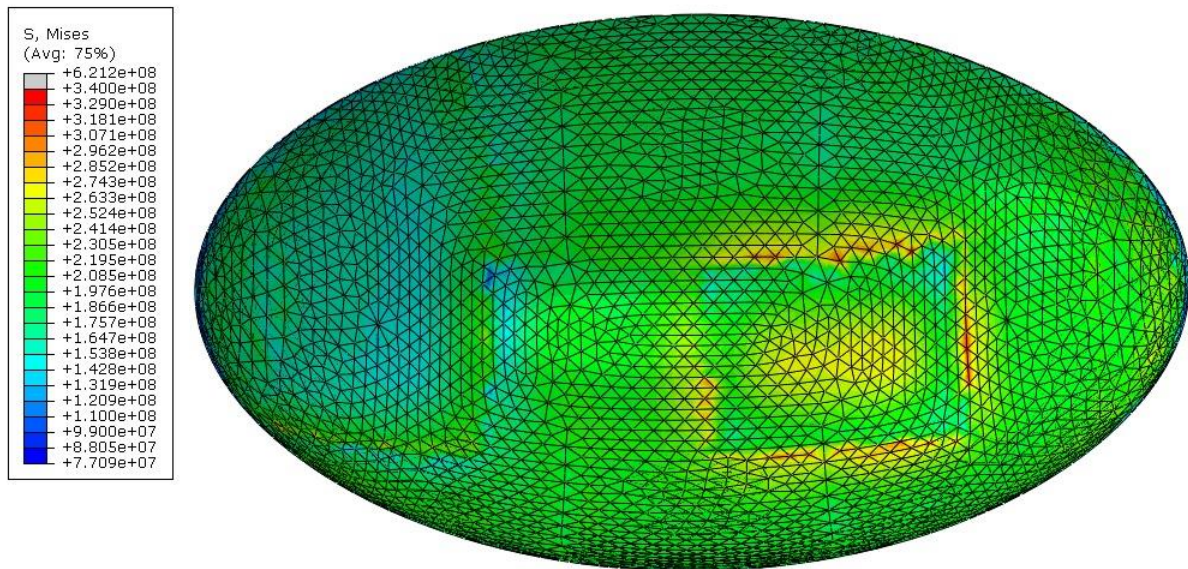

Figura 34 Espesores del Recubrimiento a lo largo del Alabe “B”

En la Figura 35, y teniendo en cuenta la Figura 22, que es la que nos indica la trayectoria adoptada para este recubrimiento, podemos observar que la temperatura en cada sector sube y decae abruptamente en los primeros ciclos para después seguir incrementando y disminuyendo la temperatura en los últimos ciclos, pero de manera más constante. Además, podemos observar que la temperatura máxima alcanzada en esta trayectoria es de **600 grados Centígrados** registrada por la termocupla 3, y como se mencionó en la Figura 9, esta termocupla se encuentra en el sector central donde la trayectoria generada se encuentra más acumulada.

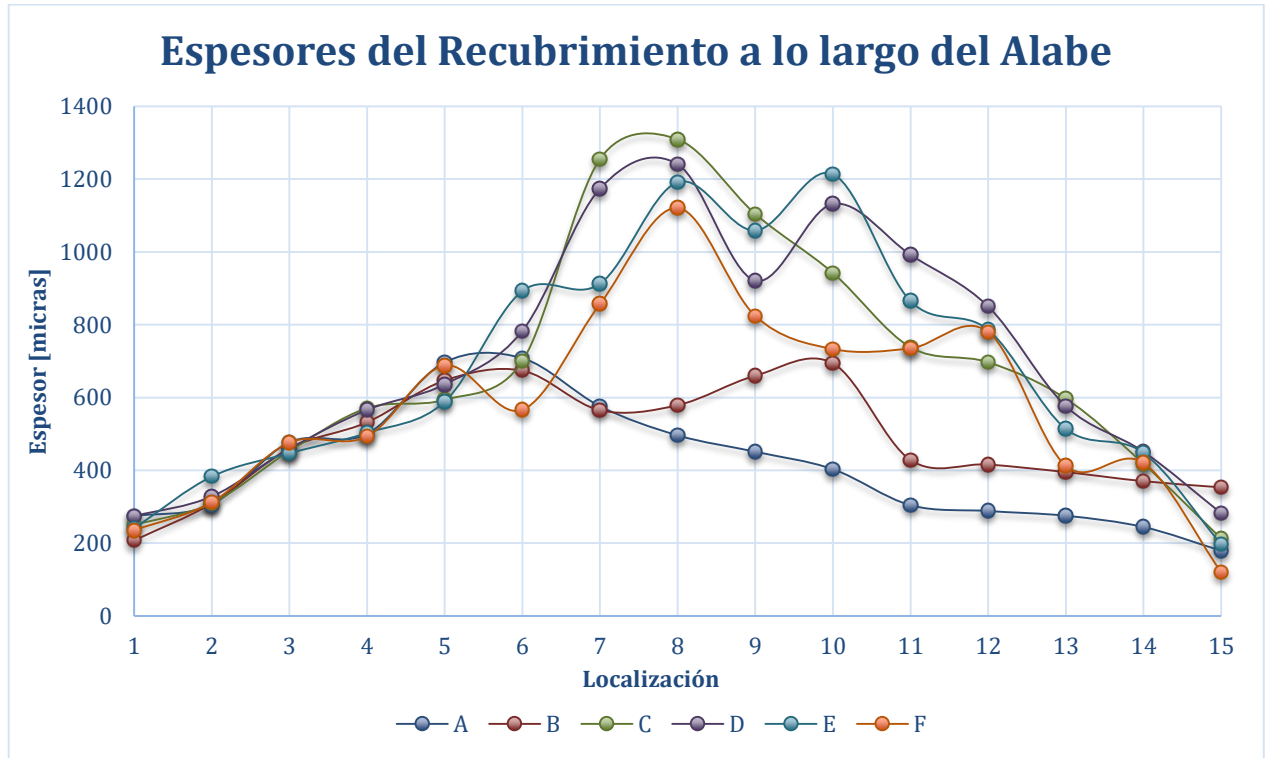

Figura 35 Distribución de la Temperatura del Sustrato durante el Recubrimiento del Alabe "B"

De igual manera que en la Trayectoria A, en la Trayectoria B como se muestra en la Figura 36 se puede observar que el enfriamiento de nuestro modelo se da de manera constante.

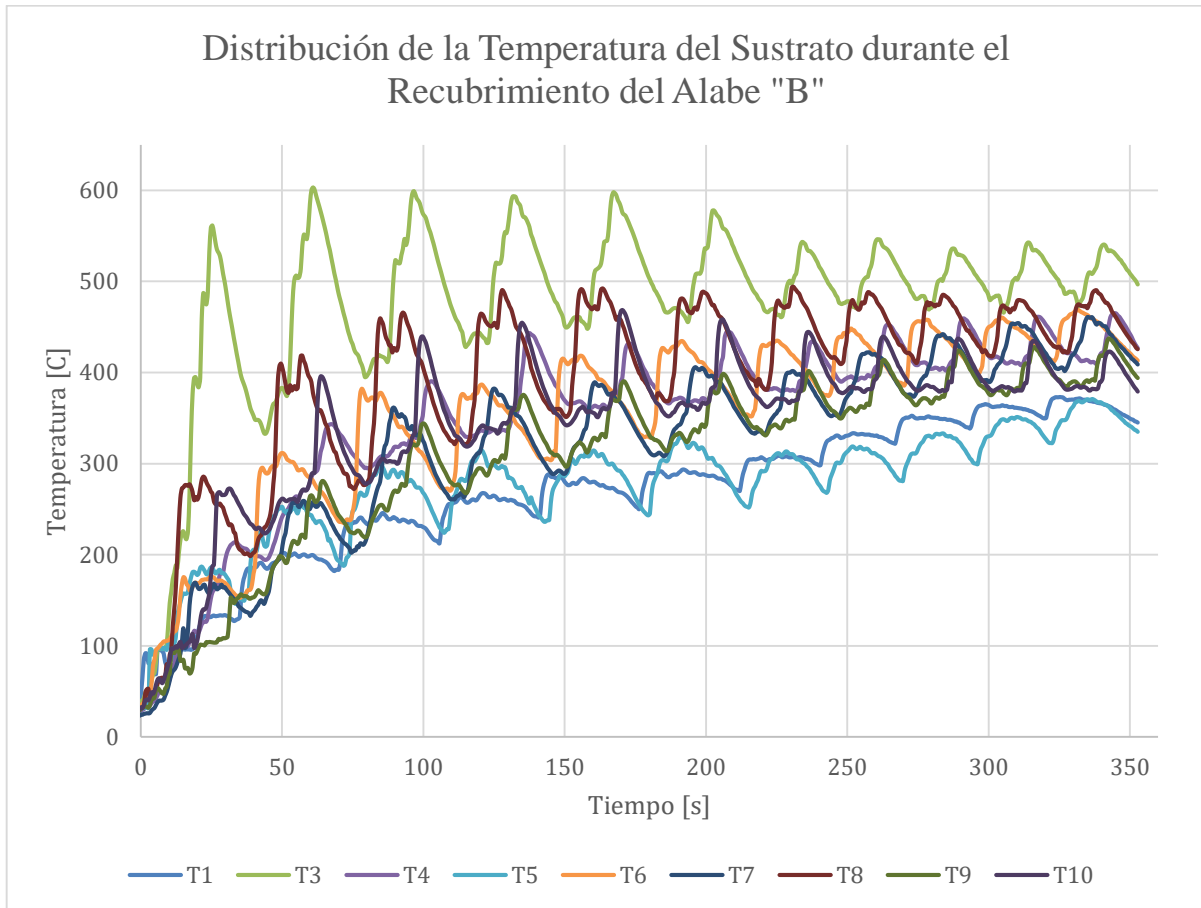

Figura 36 Distribución de la Temperatura del Sustrato durante el Enfriamiento del Alabe "B"

De la misma manera, al medir las temperaturas en cada sector de nuestro modelo para la Trayectoria B se pudo generar la simulación para encontrar los esfuerzos residuales después del proceso de metalización, con esta simulación se pudo observar en la Figura 37 que los esfuerzos residuales en S11 son de **144 [MPa]**, esto es debido a que en la zona central de nuestro modelo es donde más acumulación de calor se tuvo y en específico donde la superficie del material cambia de dirección. Asimismo, en la Figura 38, podemos observar que los esfuerzos residuales en S22 son de **119 [MPa]**, y estos se dan en la zona central de igual manera que en S11 puesto que aquí se tuvo la mayor concentración de calor y es donde la superficie del recubrimiento cambia de dirección. Por último, se observa en la Figura 39 que, los esfuerzos residuales en S33 son de **282 [MPa]**, estos esfuerzos se encuentran tanto en la zona central por la gran acumulación de calor y en las zonas externas debidas al cambio de

superficie. Con estos datos podemos saber que no existe falla ya que, los esfuerzos resultantes no sobrepasan el UTS del Níquel que es el recubrimiento. Por otro lado, podemos observar que existen esfuerzos cortantes como se muestran en la Figura 40, 41 y 42, donde los esfuerzos llegan a **145, 138 y 154 [MPa]** respectivamente en los planos S12, S13 y S23. Asimismo, en la Figura 43, podemos observar los esfuerzos mediante VonMises en los que el esfuerzo mayor es de **360 [MPa]**, todo este análisis muestra que no existe fallo en el material debido a que estos valores no superan el del UTS del Níquel.

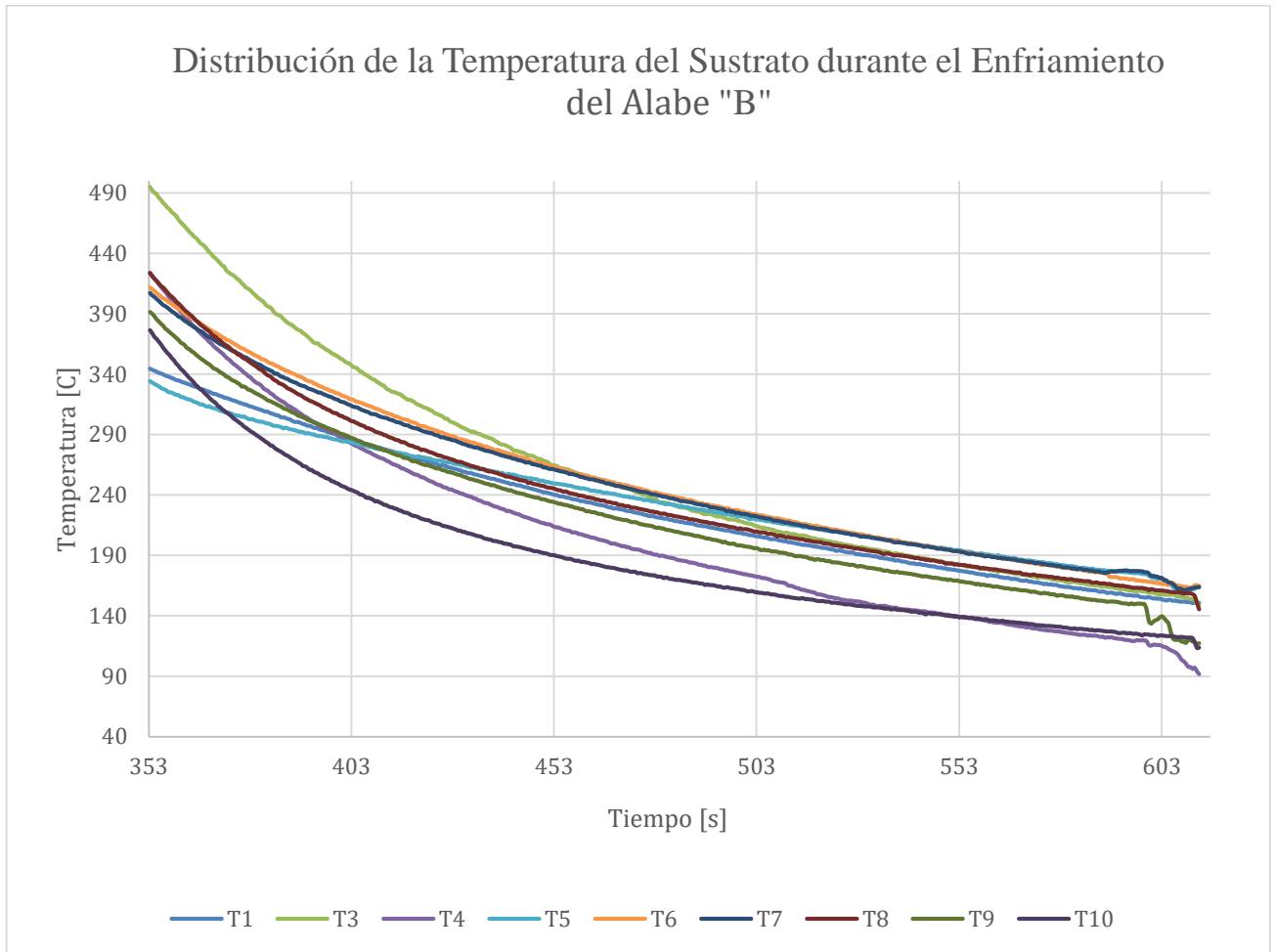

Figura 37 Simulación de Esfuerzos Residuales para la Trayectoria B (Esfuerzos en S11)



Figura 38 Simulación de Esfuerzos Residuales para la Trayectoria B (Esfuerzos en S22)

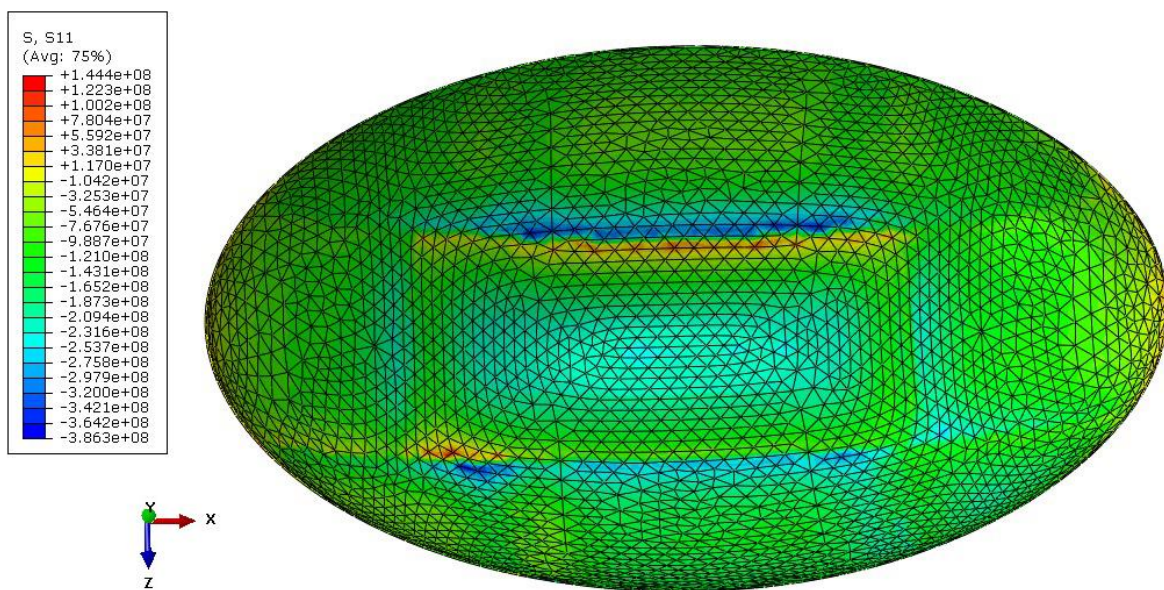

Figura 39 Simulación de Esfuerzos Residuales para la Trayectoria B (Esfuerzos en S33)

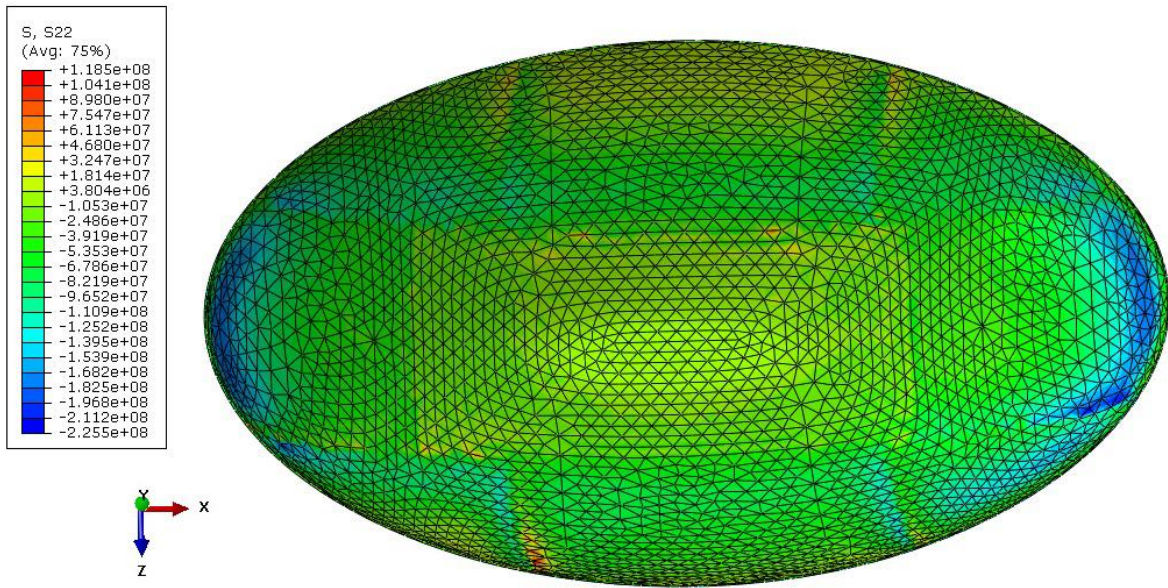

Figura 40 Simulación de Esfuerzos Residuales para la Trayectoria B (Esfuerzos en S12)

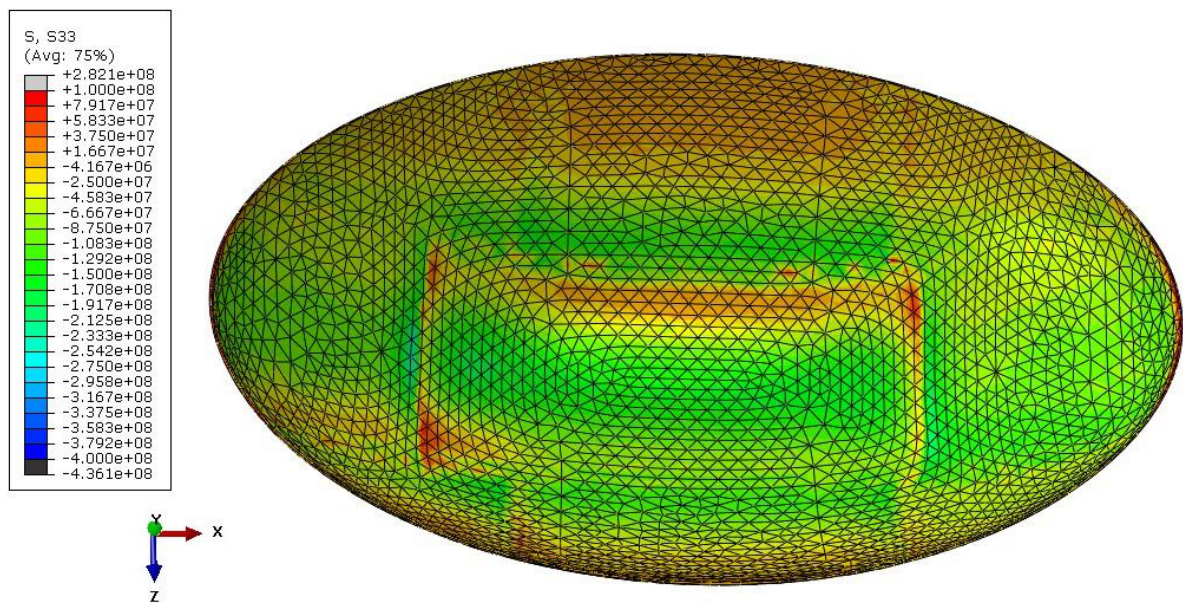

Figura 41 Simulación de Esfuerzos Residuales para la Trayectoria B (Esfuerzos en S13)

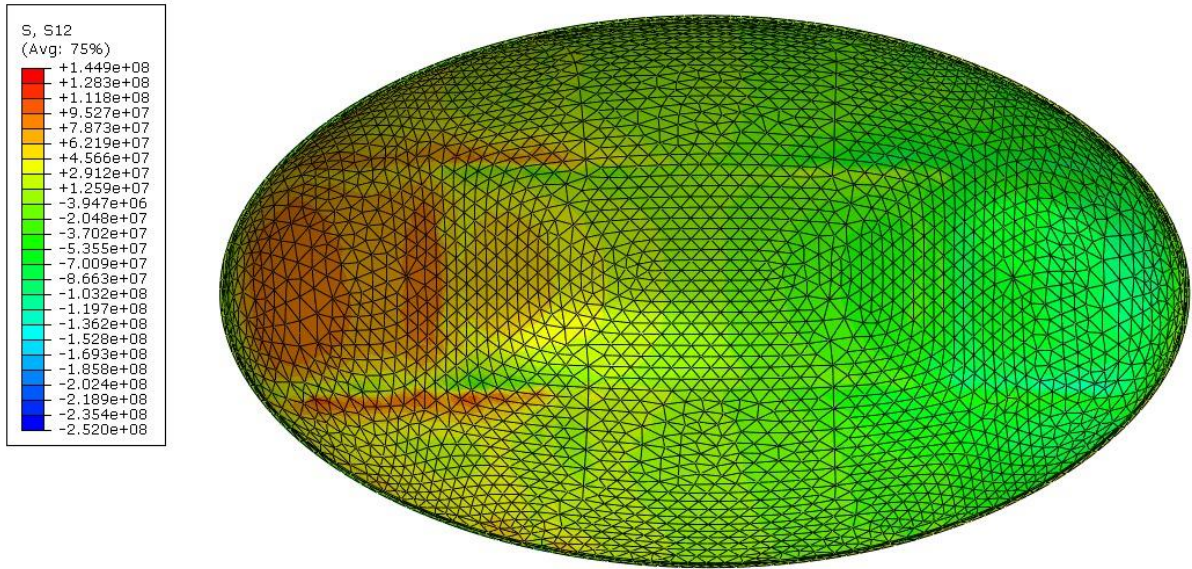

Figura 42 Simulación de Esfuerzos Residuales para la Trayectoria B (Esfuerzos en S23)

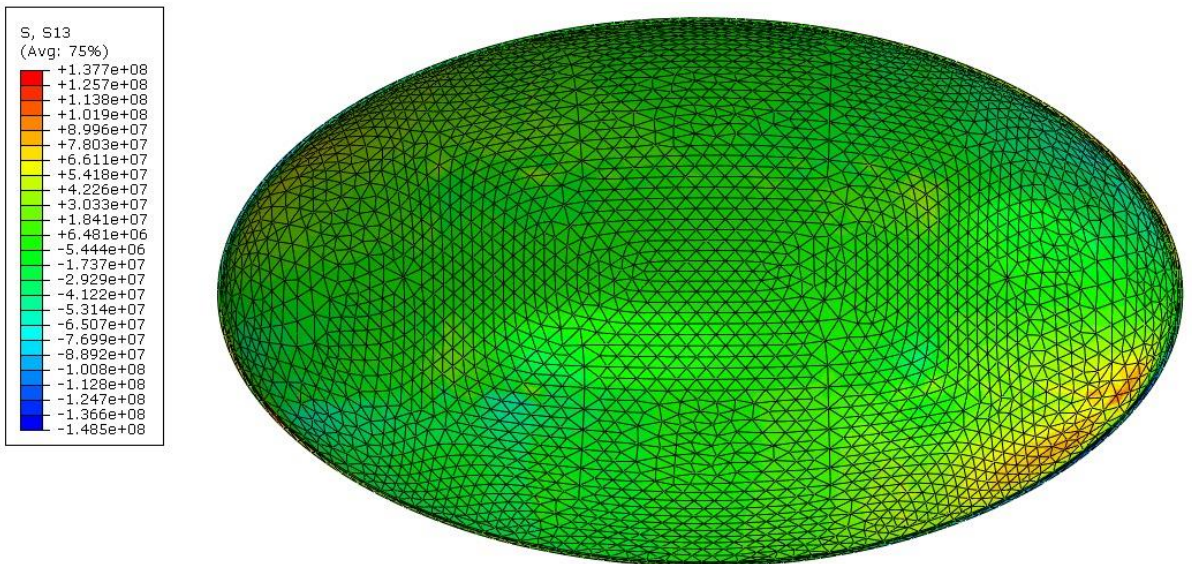

Figura 43 Simulación de Esfuerzos Residuales para la Trayectoria B (Esfuerzos de VonMises)

Discusión

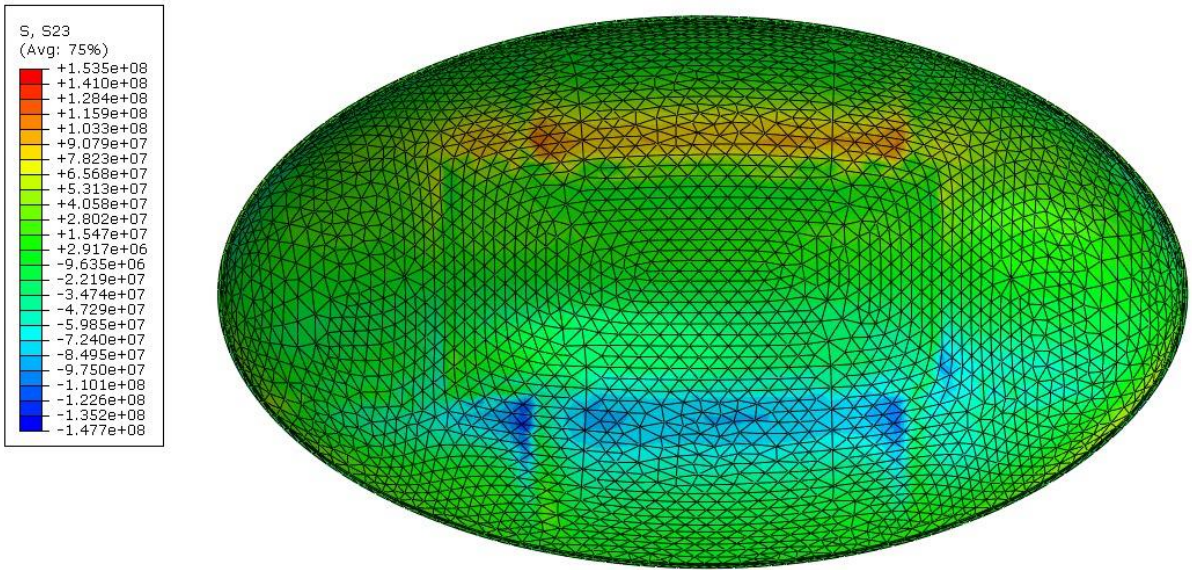
Trayectoria A

Al hablar de la Trayectoria A misma que consta de 6 pasadas de esta, se puede observar que al dividir está en dos secciones para recubrir el álabe, las temperaturas que alcanza el sustrato en las zonas externas son de **200 grados centígrados** con respecto a la zona central que llegan hasta los **500 grados centígrados** como se puede observar en la Figura 25. De igual manera, los espesores del álabe se vieron incrementados en la zona D y F en los sectores del 2 al 4 como se muestra en la Figura 24 debido a la geometría del modelo con valores que llegaron hasta las **390 micras**. Finalmente, se observó gracias a la simulación realizada para esfuerzos residuales como se muestra en las Figuras 27, 28, 29, 30, 31, 32 y 33 que, los esfuerzos de S11, S22, S33, S12, S13 y S23 son de **112, 186, 113, 118, 133 y 146 [MPa]** respectivamente. Por otro lado, en la Figura 34, se observa los esfuerzos resultados mostrados por VonMises son de **340 [MPa]**, con estos datos podemos saber que no existe falla ya que, los esfuerzos resultantes no sobrepasan el UTS del Níquel que es el recubrimiento.

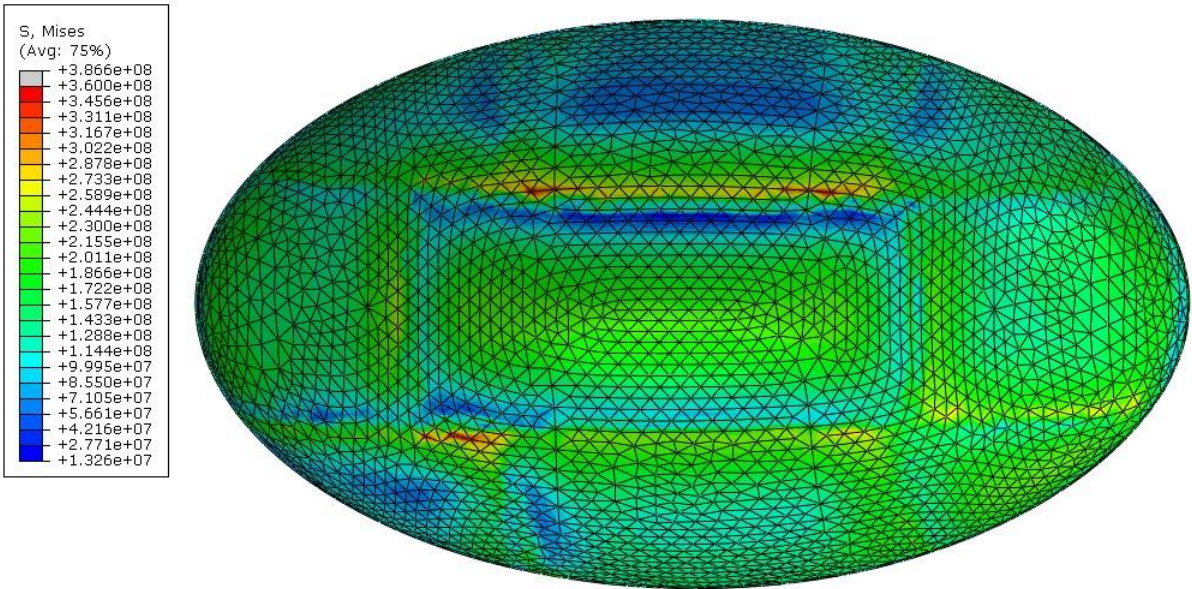
Trayectoria B

En cuanto a la Trayectoria B misma que consta de 12 pasadas de esta, se puede observar que, al ser una trayectoria de forma escalonada continua, las temperaturas que alcanza el sustrato en las zonas centrales llegan a los **600 grados centígrados**, pero, las zonas centrales llegan hasta una temperatura de **360 grados centígrados** como se puede observar en la Figura 31. De esta forma, los espesores del álabe se vieron incrementados en la zona central como se muestra en la Figura 7 con valores que llegaron hasta las **1300 micras**, esto tiene relación con el incremento de temperatura en esta zona. Por último, se pudo evidenciar gracias a la simulación realizada para esfuerzos residuales como se muestra en las Figuras 37, 38, 39, 40, 41 y 42 que, los esfuerzos de S11, S22, S33, S12, S13 y S23 son de **144, 119, 282, 145, 138 y 154 [MPa]** respectivamente. Por otro lado, en la Figura 43, se observa los esfuerzos resultados

mostrados por VonMises son de **360 [MPa]**, con estos datos podemos saber que no existe falla ya que, los esfuerzos resultantes no sobrepasan el UTS del Níquel que es el recubrimiento.

El estudio realizado en este proyecto tiene una gran importancia ya que, gracias a los análisis realizados sobre las trayectorias generadas se pueden determinar variantes de estas para conseguir una trayectoria óptima en la que el recubrimiento realizado sea homogéneo en toda la superficie del álabe, manteniendo temperaturas constantes para cada ciclo de recubrimiento y que esto haga que, los esfuerzos residuales generados en el recubrimiento no sean elevados y a su vez sean constantes en toda la extensión del recubrimiento realizando modificación en las velocidades de avance del robot en los sectores en los que se tienen ángulos o muy cerrados o muy abiertos puesto que como se observó en los resultados, estas zonas son aquellas en las que se tiene mayor acumulación de recubrimiento.

Conclusiones

En conclusión, las trayectorias generadas para recubrimientos por metalización en este estudio mediante el brazo del ROBOT KUKA KR20 adoptan los parámetros necesarios para generar recubrimientos en álabes de turbinas Pelton, y también tienen un grado de seguridad muy alto para quienes lo realicen puesto que, al tener un robot que se encargue de este proceso los operadores pueden estar alejados y libres de percibir cualquier gas nocivo que este proceso conlleva, además, de evitar quemaduras que se pueden generar por las altas temperaturas que la torcha de rociado térmico produce.

Por otro lado, se ha podido determinar y analizar el espesor del recubrimiento, llegando a la conclusión de que al tener una trayectoria que se divida en varias partes para abarcar toda la superficie del álabe, los espesores del recubrimiento se vuelven más homogéneos para la Trayectoria A (Figura 24). De igual manera, se ha podido medir la temperatura durante el proceso de metalización y al tener las trayectorias divididas la cantidad de calor proporcionado en el proceso de metalización no es tan elevado (Figura 25) y finalmente, se ha generado la

simulación de esfuerzos residuales generados en el recubrimiento, estos no llegan a valores altos como se muestran en las Figuras 27, 28, 29, 30, 31, 32, 33 y 34 ya que, al tener UTS del Níquel (Recubrimiento) de **470 [MPa]** estos esfuerzos no son críticos para el recubrimiento.

Trabajo Futuro

Para complementar este caso de estudio se recomienda estudiar y generar nuevas trayectorias que mejoren la homogeneidad del recubrimiento en los álabes y en superficies irregulares, así como en aquellas que su superficie presenta ángulos muy cerrados y/o muy abiertos.

Como se muestral en la Figura 44 y en el estudio de Duncan en 2005, esta trayectoria es una optimización muy buena para geometrías planas, en un futuro se puede adoptar este método para generar recubrimientos en los álabes.



Figura 44 Trayectoria generada por dos tramados.

(Duncan, 2005)

REFERENCIAS

- ASM HANDBOOK, Vol 7: "Powder Metal Technologies and Applications.
- ASTM C633 - 13(2017). Standard Test Method for Adhesion or Cohesion Strength of Thermal Spray Coatings
- Duncan, S. (2005). A Frequency-Domain Approach to Determining the Path Separation for Spray Coating. IEEE TRANSACTIONS ON AUTOMATION SCIENCE AND ENGINEERING, VOL. 2, NO. 3, JULY 2005.
- Deng, S., Liang, H., Zhenhua, C., Liao, H. & Montavon, G. (2014). Kinematic Optimization of Robot Trajectories for Thermal Spray Coating Application. DOI: 10.1007/s11666-014-0137-7
- Elcometer Limited. (2019). Medidor de Espesor de Revestimiento Independiente. elcometer equipos de inspección
- Eutectic Corporation. (2018). Superior Products for the Successful Practice of Maintenance & Repair Welding and Advanced Surface Coating Technologies. Technical Data Book.
- Fang, D., Deng, S., Liao, H. & Coddet, C. (2009). The Effect of Robot Kinematics on the Coating Thickness Uniformity. DOI: 10.1007/s11666-010-9470-7
- Fang, D., Zheng, Y., Zhang, B., Li, X., Ju, P., Li, H. & Zeng, C. (2018). Automatic Robot Trajectory for Thermal-Sprayed Complex Surfaces.
<https://doi.org/10.1155/2018/8697056>
- Joshi, S. & Nysten, P. (2019). Advanced Coatings by Thermal Spray Processes. Department of Engineering Science, University West, 46153 Trollhättan, Sweden;
per.nysten@hv.se

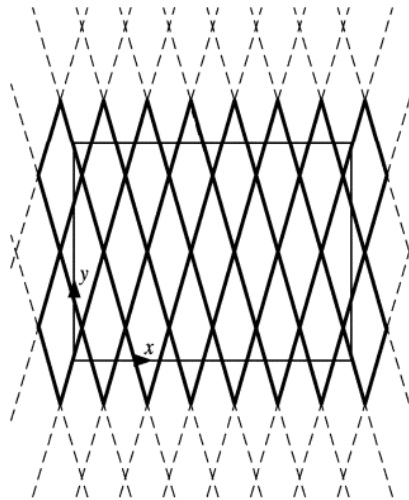
Kout, A. & Müller, H. (2009). Parameter optimization for spray coating. *Advances in Engineering Software* 40 (2009) 1078–1086. Dortmund University of Technology, Informatik VII, Otto-Hahn-Str. 16, D-44227 Dortmund, Germany

Manual de Operaciones de KUKA: KR 20-3 With C Variants Assembly Instructions.

ANEXOS

Código para la programación de la Trayectoria A

Extensión .src

```

&ACCESS RVP
&REL 175
&PARAM EDITMASK = *
&PARAM TEMPLATE = C:\KRC\Roboter\Template\vorgabe
DEF pelton3( )
:FOLD INI;% {PE}
  :FOLD BASISTECH INI
    GLOBAL INTERRUPT DECL 3 WHEN $STOPMESS==TRUE DO IR_STOPM ( )
    INTERRUPT ON 3
    BAS (#INITMOV,0 )
  :ENDFOLD (BASISTECH INI)
  :FOLD USER INI
    ;Make your modifications here

  :ENDFOLD (USER INI)
:ENDFOLD (INI)

:FOLD PTP P1 Vel=100 % PDAT1 Tool[10]:b1 Base[14]:b1;% {PE}%R 8.3.44,%MKUKATPBASIS,%CMOVE,%VPTP,%P 1:PTP, 2:P1,
3:, 5:100, 7:PDAT1
$BWDSTART=FALSE
PDAT_ACT=PPDAT1
FDAT_ACT=FP1
BAS(#PTP_PARAMS,100)
PTP XP1
:ENDFOLD
LOOP
:FOLD LIN P2 Vel=1 m/s CPDAT1 Tool[10]:b1 Base[14]:b1;% {PE}%R 8.3.44,%MKUKATPBASIS,%CMOVE,%VLIN,%P 1:LIN, 2:P2,
3:, 5:1, 7:CPDAT1
$BWDSTART=FALSE
LDAT_ACT=LCPDAT1
FDAT_ACT=FP2
BAS(#CP_PARAMS,1)
LIN XP2
:ENDFOLD

:FOLD LIN P41 CONT Vel=1 m/s CPDAT40 Tool[10]:b1 Base[14]:b1;% {PE}%R 8.3.44,%MKUKATPBASIS,%CMOVE,%VLIN,%P
1:LIN, 2:P41, 3:C_DIS C_DIS, 5:1, 7:CPDAT40
$BWDSTART=FALSE
LDAT_ACT=LCPDAT40
FDAT_ACT=FP41
BAS(#CP_PARAMS,1)
LIN XP41 C_DIS C_DIS
:ENDFOLD

:FOLD LIN P43 CONT Vel=1 m/s CPDAT42 Tool[10]:b1 Base[14]:b1;% {PE}%R 8.3.44,%MKUKATPBASIS,%CMOVE,%VLIN,%P
1:LIN, 2:P43, 3:C_DIS C_DIS, 5:1, 7:CPDAT42
$BWDSTART=FALSE
LDAT_ACT=LCPDAT42
FDAT_ACT=FP43
BAS(#CP_PARAMS,1)
LIN XP43 C_DIS C_DIS
:ENDFOLD

:FOLD LIN P44 CONT Vel=1 m/s CPDAT43 Tool[10]:b1 Base[14]:b1;% {PE}%R 8.3.44,%MKUKATPBASIS,%CMOVE,%VLIN,%P
1:LIN, 2:P44, 3:C_DIS C_DIS, 5:1, 7:CPDAT43
$BWDSTART=FALSE
LDAT_ACT=LCPDAT43
FDAT_ACT=FP44
BAS(#CP_PARAMS,1)
LIN XP44 C_DIS C_DIS
:ENDFOLD

:FOLD LIN P45 CONT Vel=1 m/s CPDAT44 Tool[10]:b1 Base[14]:b1;% {PE}%R 8.3.44,%MKUKATPBASIS,%CMOVE,%VLIN,%P
1:LIN, 2:P45, 3:C_DIS C_DIS, 5:1, 7:CPDAT44
$BWDSTART=FALSE
LDAT_ACT=LCPDAT44
FDAT_ACT=FP45

```

```

BAS(#CP_PARAMS,1)
LIN XP45 C_DIS C_DIS
:ENDFOLD
:FOLD LIN P46 CONT Vel=1 m/s CPDAT45 Tool[10]:b1 Base[14]:b1;%{PE}%R 8.3.44,%MKUKATPBASIS,%CMOVE,%VLIN,%P
1:LIN, 2:P46, 3:C_DIS C_DIS, 5:1, 7:CPDAT45
$BWDSTART=FALSE
LDAT_ACT=LCPDAT45
FDAT_ACT=FP46
BAS(#CP_PARAMS,1)
LIN XP46 C_DIS C_DIS
:ENDFOLD
:FOLD LIN P47 CONT Vel=1 m/s CPDAT46 Tool[10]:b1 Base[14]:b1;%{PE}%R 8.3.44,%MKUKATPBASIS,%CMOVE,%VLIN,%P
1:LIN, 2:P47, 3:C_DIS C_DIS, 5:1, 7:CPDAT46
$BWDSTART=FALSE
LDAT_ACT=LCPDAT46
FDAT_ACT=FP47
BAS(#CP_PARAMS,1)
LIN XP47 C_DIS C_DIS
:ENDFOLD
:FOLD LIN P48 CONT Vel=1 m/s CPDAT47 Tool[10]:b1 Base[14]:b1;%{PE}%R 8.3.44,%MKUKATPBASIS,%CMOVE,%VLIN,%P
1:LIN, 2:P48, 3:C_DIS C_DIS, 5:1, 7:CPDAT47
$BWDSTART=FALSE
LDAT_ACT=LCPDAT47
FDAT_ACT=FP48
BAS(#CP_PARAMS,1)
LIN XP48 C_DIS C_DIS
:ENDFOLD
:FOLD LIN P49 CONT Vel=1 m/s CPDAT48 Tool[10]:b1 Base[14]:b1;%{PE}%R 8.3.44,%MKUKATPBASIS,%CMOVE,%VLIN,%P
1:LIN, 2:P49, 3:C_DIS C_DIS, 5:1, 7:CPDAT48
$BWDSTART=FALSE
LDAT_ACT=LCPDAT48
FDAT_ACT=FP49
BAS(#CP_PARAMS,1)
LIN XP49 C_DIS C_DIS
:ENDFOLD
:FOLD LIN P50 CONT Vel=1 m/s CPDAT49 Tool[10]:b1 Base[14]:b1;%{PE}%R 8.3.44,%MKUKATPBASIS,%CMOVE,%VLIN,%P
1:LIN, 2:P50, 3:C_DIS C_DIS, 5:1, 7:CPDAT49
$BWDSTART=FALSE
LDAT_ACT=LCPDAT49
FDAT_ACT=FP50
BAS(#CP_PARAMS,1)
LIN XP50 C_DIS C_DIS
:ENDFOLD
:FOLD LIN P52 CONT Vel=1 m/s CPDAT51 Tool[10]:b1 Base[14]:b1;%{PE}%R 8.3.44,%MKUKATPBASIS,%CMOVE,%VLIN,%P
1:LIN, 2:P52, 3:C_DIS C_DIS, 5:1, 7:CPDAT51
$BWDSTART=FALSE
LDAT_ACT=LCPDAT51
FDAT_ACT=FP52
BAS(#CP_PARAMS,1)
LIN XP52 C_DIS C_DIS
:ENDFOLD
:FOLD LIN P53 CONT Vel=1 m/s CPDAT52 Tool[10]:b1 Base[14]:b1;%{PE}%R 8.3.44,%MKUKATPBASIS,%CMOVE,%VLIN,%P
1:LIN, 2:P53, 3:C_DIS C_DIS, 5:1, 7:CPDAT52
$BWDSTART=FALSE
LDAT_ACT=LCPDAT52
FDAT_ACT=FP53
BAS(#CP_PARAMS,1)
LIN XP53 C_DIS C_DIS
:ENDFOLD
:FOLD LIN P54 CONT Vel=1 m/s CPDAT53 Tool[10]:b1 Base[14]:b1;%{PE}%R 8.3.44,%MKUKATPBASIS,%CMOVE,%VLIN,%P
1:LIN, 2:P54, 3:C_DIS C_DIS, 5:1, 7:CPDAT53
$BWDSTART=FALSE
LDAT_ACT=LCPDAT53
FDAT_ACT=FP54
BAS(#CP_PARAMS,1)
LIN XP54 C_DIS C_DIS
:ENDFOLD
:FOLD LIN P55 CONT Vel=1 m/s CPDAT54 Tool[10]:b1 Base[14]:b1;%{PE}%R 8.3.44,%MKUKATPBASIS,%CMOVE,%VLIN,%P
1:LIN, 2:P55, 3:C_DIS C_DIS, 5:1, 7:CPDAT54
$BWDSTART=FALSE
LDAT_ACT=LCPDAT54
FDAT_ACT=FP55
BAS(#CP_PARAMS,1)
LIN XP55 C_DIS C_DIS
:ENDFOLD

```

```

:FOLD LIN P56 CONT Vel=1 m/s CPDAT55 Tool[10]:b1 Base[14]:b1;% {PE}%R 8.3.44,%MKUKATPBASIS,%CMOVE,%VLIN,%P
1:LIN, 2:P56, 3:C_DIS C_DIS, 5:1, 7:CPDAT55
$BWDSTART=FALSE
LDAT_ACT=LCPDAT55
FDAT_ACT=FP56
BAS(#CP_PARAMS,1)
LIN XP56 C_DIS C_DIS
:ENDFOLD
:FOLD LIN P57 CONT Vel=1 m/s CPDAT56 Tool[10]:b1 Base[14]:b1;% {PE}%R 8.3.44,%MKUKATPBASIS,%CMOVE,%VLIN,%P
1:LIN, 2:P57, 3:C_DIS C_DIS, 5:1, 7:CPDAT56
$BWDSTART=FALSE
LDAT_ACT=LCPDAT56
FDAT_ACT=FP57
BAS(#CP_PARAMS,1)
LIN XP57 C_DIS C_DIS
:ENDFOLD
:FOLD LIN P58 CONT Vel=1 m/s CPDAT57 Tool[10]:b1 Base[14]:b1;% {PE}%R 8.3.44,%MKUKATPBASIS,%CMOVE,%VLIN,%P
1:LIN, 2:P58, 3:C_DIS C_DIS, 5:1, 7:CPDAT57
$BWDSTART=FALSE
LDAT_ACT=LCPDAT57
FDAT_ACT=FP58
BAS(#CP_PARAMS,1)
LIN XP58 C_DIS C_DIS
:ENDFOLD
:FOLD LIN P59 CONT Vel=1 m/s CPDAT58 Tool[10]:b1 Base[14]:b1;% {PE}%R 8.3.44,%MKUKATPBASIS,%CMOVE,%VLIN,%P
1:LIN, 2:P59, 3:C_DIS C_DIS, 5:1, 7:CPDAT58
$BWDSTART=FALSE
LDAT_ACT=LCPDAT58
FDAT_ACT=FP59
BAS(#CP_PARAMS,1)
LIN XP59 C_DIS C_DIS
:ENDFOLD
:FOLD LIN P60 CONT Vel=1 m/s CPDAT59 Tool[10]:b1 Base[14]:b1;% {PE}%R 8.3.44,%MKUKATPBASIS,%CMOVE,%VLIN,%P
1:LIN, 2:P60, 3:C_DIS C_DIS, 5:1, 7:CPDAT59
$BWDSTART=FALSE
LDAT_ACT=LCPDAT59
FDAT_ACT=FP60
BAS(#CP_PARAMS,1)
LIN XP60 C_DIS C_DIS
:ENDFOLD
:FOLD LIN P111 CONT Vel=1 m/s CPDAT110 Tool[10]:b1 Base[14]:b1;% {PE}%R 8.3.44,%MKUKATPBASIS,%CMOVE,%VLIN,%P
1:LIN, 2:P111, 3:C_DIS C_DIS, 5:1, 7:CPDAT110
$BWDSTART=FALSE
LDAT_ACT=LCPDAT110
FDAT_ACT=FP111
BAS(#CP_PARAMS,1)
LIN XP111 C_DIS C_DIS
:ENDFOLD
:FOLD LIN P112 CONT Vel=1 m/s CPDAT111 Tool[10]:b1 Base[14]:b1;% {PE}%R 8.3.44,%MKUKATPBASIS,%CMOVE,%VLIN,%P
1:LIN, 2:P112, 3:C_DIS C_DIS, 5:1, 7:CPDAT111
$BWDSTART=FALSE
LDAT_ACT=LCPDAT111
FDAT_ACT=FP112
BAS(#CP_PARAMS,1)
LIN XP112 C_DIS C_DIS
:ENDFOLD
:FOLD LIN P113 CONT Vel=1 m/s CPDAT112 Tool[10]:b1 Base[14]:b1;% {PE}%R 8.3.44,%MKUKATPBASIS,%CMOVE,%VLIN,%P
1:LIN, 2:P113, 3:C_DIS C_DIS, 5:1, 7:CPDAT112
$BWDSTART=FALSE
LDAT_ACT=LCPDAT112
FDAT_ACT=FP113
BAS(#CP_PARAMS,1)
LIN XP113 C_DIS C_DIS
:ENDFOLD
:FOLD LIN P114 CONT Vel=1 m/s CPDAT113 Tool[10]:b1 Base[14]:b1;% {PE}%R 8.3.44,%MKUKATPBASIS,%CMOVE,%VLIN,%P
1:LIN, 2:P114, 3:C_DIS C_DIS, 5:1, 7:CPDAT113
$BWDSTART=FALSE
LDAT_ACT=LCPDAT113
FDAT_ACT=FP114
BAS(#CP_PARAMS,1)
LIN XP114 C_DIS C_DIS
:ENDFOLD
:FOLD LIN P115 CONT Vel=1 m/s CPDAT114 Tool[10]:b1 Base[14]:b1;% {PE}%R 8.3.44,%MKUKATPBASIS,%CMOVE,%VLIN,%P
1:LIN, 2:P115, 3:C_DIS C_DIS, 5:1, 7:CPDAT114
$BWDSTART=FALSE

```

```

LDAT_ACT=LCPDAT114
FDAT_ACT=FP115
BAS(#CP_PARAMS,1)
LIN XP115 C_DIS C_DIS
:ENDFOLD
:FOLD LIN P116 CONT Vel=1 m/s CPDAT115 Tool[10]:b1 Base[14]:b1;% {PE}%R 8.3.44,%MKUKATPBASIS,%CMOVE,%VLIN,%P
1:LIN, 2:P116, 3:C_DIS C_DIS, 5:1, 7:CPDAT115
$BWDSTART=FALSE
LDAT_ACT=LCPDAT115
FDAT_ACT=FP116
BAS(#CP_PARAMS,1)
LIN XP116 C_DIS C_DIS
:ENDFOLD
:FOLD LIN P117 CONT Vel=1 m/s CPDAT116 Tool[10]:b1 Base[14]:b1;% {PE}%R 8.3.44,%MKUKATPBASIS,%CMOVE,%VLIN,%P
1:LIN, 2:P117, 3:C_DIS C_DIS, 5:1, 7:CPDAT116
$BWDSTART=FALSE
LDAT_ACT=LCPDAT116
FDAT_ACT=FP117
BAS(#CP_PARAMS,1)
LIN XP117 C_DIS C_DIS
:ENDFOLD
:FOLD LIN P118 CONT Vel=1 m/s CPDAT117 Tool[10]:b1 Base[14]:b1;% {PE}%R 8.3.44,%MKUKATPBASIS,%CMOVE,%VLIN,%P
1:LIN, 2:P118, 3:C_DIS C_DIS, 5:1, 7:CPDAT117
$BWDSTART=FALSE
LDAT_ACT=LCPDAT117
FDAT_ACT=FP118
BAS(#CP_PARAMS,1)
LIN XP118 C_DIS C_DIS
:ENDFOLD
:FOLD LIN P119 CONT Vel=1 m/s CPDAT118 Tool[10]:b1 Base[14]:b1;% {PE}%R 8.3.44,%MKUKATPBASIS,%CMOVE,%VLIN,%P
1:LIN, 2:P119, 3:C_DIS C_DIS, 5:1, 7:CPDAT118
$BWDSTART=FALSE
LDAT_ACT=LCPDAT118
FDAT_ACT=FP119
BAS(#CP_PARAMS,1)
LIN XP119 C_DIS C_DIS
:ENDFOLD
:FOLD LIN P120 CONT Vel=1 m/s CPDAT119 Tool[10]:b1 Base[14]:b1;% {PE}%R 8.3.44,%MKUKATPBASIS,%CMOVE,%VLIN,%P
1:LIN, 2:P120, 3:C_DIS C_DIS, 5:1, 7:CPDAT119
$BWDSTART=FALSE
LDAT_ACT=LCPDAT119
FDAT_ACT=FP120
BAS(#CP_PARAMS,1)
LIN XP120 C_DIS C_DIS
:ENDFOLD
:FOLD LIN P121 CONT Vel=1 m/s CPDAT120 Tool[10]:b1 Base[14]:b1;% {PE}%R 8.3.44,%MKUKATPBASIS,%CMOVE,%VLIN,%P
1:LIN, 2:P121, 3:C_DIS C_DIS, 5:1, 7:CPDAT120
$BWDSTART=FALSE
LDAT_ACT=LCPDAT120
FDAT_ACT=FP121
BAS(#CP_PARAMS,1)
LIN XP121 C_DIS C_DIS
:ENDFOLD
:FOLD LIN P122 CONT Vel=1 m/s CPDAT121 Tool[10]:b1 Base[14]:b1;% {PE}%R 8.3.44,%MKUKATPBASIS,%CMOVE,%VLIN,%P
1:LIN, 2:P122, 3:C_DIS C_DIS, 5:1, 7:CPDAT121
$BWDSTART=FALSE
LDAT_ACT=LCPDAT121
FDAT_ACT=FP122
BAS(#CP_PARAMS,1)
LIN XP122 C_DIS C_DIS
:ENDFOLD
:FOLD LIN P123 CONT Vel=1 m/s CPDAT122 Tool[10]:b1 Base[14]:b1;% {PE}%R 8.3.44,%MKUKATPBASIS,%CMOVE,%VLIN,%P
1:LIN, 2:P123, 3:C_DIS C_DIS, 5:1, 7:CPDAT122
$BWDSTART=FALSE
LDAT_ACT=LCPDAT122
FDAT_ACT=FP123
BAS(#CP_PARAMS,1)
LIN XP123 C_DIS C_DIS
:ENDFOLD
:FOLD LIN P62 CONT Vel=1 m/s CPDAT61 Tool[10]:b1 Base[14]:b1;% {PE}%R 8.3.44,%MKUKATPBASIS,%CMOVE,%VLIN,%P
1:LIN, 2:P62, 3:C_DIS C_DIS, 5:1, 7:CPDAT61
$BWDSTART=FALSE
LDAT_ACT=LCPDAT61
FDAT_ACT=FP62
BAS(#CP_PARAMS,1)

```

```

LIN XP62 C_DIS C_DIS
:ENDFOLD
:FOLD LIN P63 CONT Vel=1 m/s CPDAT62 Tool[10]:b1 Base[14]:b1;% {PE}%R 8.3.44,%MKUKATPBASIS,%CMOVE,%VLIN,%P
1:LIN, 2:P63, 3:C_DIS C_DIS, 5:1, 7:CPDAT62
$BWDSTART=FALSE
LDAT_ACT=LCPDAT62
FDAT_ACT=FP63
BAS(#CP_PARAMS,1)
LIN XP63 C_DIS C_DIS
:ENDFOLD
:FOLD LIN P64 CONT Vel=1 m/s CPDAT63 Tool[10]:b1 Base[14]:b1;% {PE}%R 8.3.44,%MKUKATPBASIS,%CMOVE,%VLIN,%P
1:LIN, 2:P64, 3:C_DIS C_DIS, 5:1, 7:CPDAT63
$BWDSTART=FALSE
LDAT_ACT=LCPDAT63
FDAT_ACT=FP64
BAS(#CP_PARAMS,1)
LIN XP64 C_DIS C_DIS
:ENDFOLD
:FOLD LIN P68 CONT Vel=1 m/s CPDAT67 Tool[10]:b1 Base[14]:b1;% {PE}%R 8.3.44,%MKUKATPBASIS,%CMOVE,%VLIN,%P
1:LIN, 2:P68, 3:C_DIS C_DIS, 5:1, 7:CPDAT67
$BWDSTART=FALSE
LDAT_ACT=LCPDAT67
FDAT_ACT=FP68
BAS(#CP_PARAMS,1)
LIN XP68 C_DIS C_DIS
:ENDFOLD
:FOLD LIN P69 CONT Vel=1 m/s CPDAT68 Tool[10]:b1 Base[14]:b1;% {PE}%R 8.3.44,%MKUKATPBASIS,%CMOVE,%VLIN,%P
1:LIN, 2:P69, 3:C_DIS C_DIS, 5:1, 7:CPDAT68
$BWDSTART=FALSE
LDAT_ACT=LCPDAT68
FDAT_ACT=FP69
BAS(#CP_PARAMS,1)
LIN XP69 C_DIS C_DIS
:ENDFOLD
:FOLD LIN P70 CONT Vel=1 m/s CPDAT69 Tool[10]:b1 Base[14]:b1;% {PE}%R 8.3.44,%MKUKATPBASIS,%CMOVE,%VLIN,%P
1:LIN, 2:P70, 3:C_DIS C_DIS, 5:1, 7:CPDAT69
$BWDSTART=FALSE
LDAT_ACT=LCPDAT69
FDAT_ACT=FP70
BAS(#CP_PARAMS,1)
LIN XP70 C_DIS C_DIS
:ENDFOLD
:FOLD LIN P71 CONT Vel=1 m/s CPDAT70 Tool[10]:b1 Base[14]:b1;% {PE}%R 8.3.44,%MKUKATPBASIS,%CMOVE,%VLIN,%P
1:LIN, 2:P71, 3:C_DIS C_DIS, 5:1, 7:CPDAT70
$BWDSTART=FALSE
LDAT_ACT=LCPDAT70
FDAT_ACT=FP71
BAS(#CP_PARAMS,1)
LIN XP71 C_DIS C_DIS
:ENDFOLD
:FOLD LIN P72 CONT Vel=1 m/s CPDAT71 Tool[10]:b1 Base[14]:b1;% {PE}%R 8.3.44,%MKUKATPBASIS,%CMOVE,%VLIN,%P
1:LIN, 2:P72, 3:C_DIS C_DIS, 5:1, 7:CPDAT71
$BWDSTART=FALSE
LDAT_ACT=LCPDAT71
FDAT_ACT=FP72
BAS(#CP_PARAMS,1)
LIN XP72 C_DIS C_DIS
:ENDFOLD
:FOLD LIN P73 CONT Vel=1 m/s CPDAT72 Tool[10]:b1 Base[14]:b1;% {PE}%R 8.3.44,%MKUKATPBASIS,%CMOVE,%VLIN,%P
1:LIN, 2:P73, 3:C_DIS C_DIS, 5:1, 7:CPDAT72
$BWDSTART=FALSE
LDAT_ACT=LCPDAT72
FDAT_ACT=FP73
BAS(#CP_PARAMS,1)
LIN XP73 C_DIS C_DIS
:ENDFOLD
:FOLD LIN P74 CONT Vel=1 m/s CPDAT73 Tool[10]:b1 Base[14]:b1;% {PE}%R 8.3.44,%MKUKATPBASIS,%CMOVE,%VLIN,%P
1:LIN, 2:P74, 3:C_DIS C_DIS, 5:1, 7:CPDAT73
$BWDSTART=FALSE
LDAT_ACT=LCPDAT73
FDAT_ACT=FP74
BAS(#CP_PARAMS,1)
LIN XP74 C_DIS C_DIS
:ENDFOLD

```

```

:FOLD LIN P75 CONT Vel=1 m/s CPDAT74 Tool[10]:b1 Base[14]:b1;% {PE}%R 8.3.44,%MKUKATPBASIS,%CMOVE,%VLIN,%P
1:LIN, 2:P75, 3:C_DIS C_DIS, 5:1, 7:CPDAT74
$BWDSTART=FALSE
LDAT_ACT=LCPDAT74
FDAT_ACT=FP75
BAS(#CP_PARAMS,1)
LIN XP75 C_DIS C_DIS
:ENDFOLD
:FOLD LIN P77 CONT Vel=1 m/s CPDAT76 Tool[10]:b1 Base[14]:b1;% {PE}%R 8.3.44,%MKUKATPBASIS,%CMOVE,%VLIN,%P
1:LIN, 2:P77, 3:C_DIS C_DIS, 5:1, 7:CPDAT76
$BWDSTART=FALSE
LDAT_ACT=LCPDAT76
FDAT_ACT=FP77
BAS(#CP_PARAMS,1)
LIN XP77 C_DIS C_DIS
:ENDFOLD
:FOLD LIN P78 CONT Vel=1 m/s CPDAT77 Tool[10]:b1 Base[14]:b1;% {PE}%R 8.3.44,%MKUKATPBASIS,%CMOVE,%VLIN,%P
1:LIN, 2:P78, 3:C_DIS C_DIS, 5:1, 7:CPDAT77
$BWDSTART=FALSE
LDAT_ACT=LCPDAT77
FDAT_ACT=FP78
BAS(#CP_PARAMS,1)
LIN XP78 C_DIS C_DIS
:ENDFOLD
:FOLD LIN P79 CONT Vel=1 m/s CPDAT78 Tool[10]:b1 Base[14]:b1;% {PE}%R 8.3.44,%MKUKATPBASIS,%CMOVE,%VLIN,%P
1:LIN, 2:P79, 3:C_DIS C_DIS, 5:1, 7:CPDAT78
$BWDSTART=FALSE
LDAT_ACT=LCPDAT78
FDAT_ACT=FP79
BAS(#CP_PARAMS,1)
LIN XP79 C_DIS C_DIS
:ENDFOLD
:FOLD LIN P80 CONT Vel=1 m/s CPDAT79 Tool[10]:b1 Base[14]:b1;% {PE}%R 8.3.44,%MKUKATPBASIS,%CMOVE,%VLIN,%P
1:LIN, 2:P80, 3:C_DIS C_DIS, 5:1, 7:CPDAT79
$BWDSTART=FALSE
LDAT_ACT=LCPDAT79
FDAT_ACT=FP80
BAS(#CP_PARAMS,1)
LIN XP80 C_DIS C_DIS
:ENDFOLD
:FOLD LIN P81 CONT Vel=1 m/s CPDAT80 Tool[10]:b1 Base[14]:b1;% {PE}%R 8.3.44,%MKUKATPBASIS,%CMOVE,%VLIN,%P
1:LIN, 2:P81, 3:C_DIS C_DIS, 5:1, 7:CPDAT80
$BWDSTART=FALSE
LDAT_ACT=LCPDAT80
FDAT_ACT=FP81
BAS(#CP_PARAMS,1)
LIN XP81 C_DIS C_DIS
:ENDFOLD
:FOLD LIN P82 CONT Vel=1 m/s CPDAT81 Tool[10]:b1 Base[14]:b1;% {PE}%R 8.3.44,%MKUKATPBASIS,%CMOVE,%VLIN,%P
1:LIN, 2:P82, 3:C_DIS C_DIS, 5:1, 7:CPDAT81
$BWDSTART=FALSE
LDAT_ACT=LCPDAT81
FDAT_ACT=FP82
BAS(#CP_PARAMS,1)
LIN XP82 C_DIS C_DIS
:ENDFOLD
:FOLD LIN P83 CONT Vel=1 m/s CPDAT82 Tool[10]:b1 Base[14]:b1;% {PE}%R 8.3.44,%MKUKATPBASIS,%CMOVE,%VLIN,%P
1:LIN, 2:P83, 3:C_DIS C_DIS, 5:1, 7:CPDAT82
$BWDSTART=FALSE
LDAT_ACT=LCPDAT82
FDAT_ACT=FP83
BAS(#CP_PARAMS,1)
LIN XP83 C_DIS C_DIS
:ENDFOLD
:FOLD LIN P84 CONT Vel=1 m/s CPDAT83 Tool[10]:b1 Base[14]:b1;% {PE}%R 8.3.44,%MKUKATPBASIS,%CMOVE,%VLIN,%P
1:LIN, 2:P84, 3:C_DIS C_DIS, 5:1, 7:CPDAT83
$BWDSTART=FALSE
LDAT_ACT=LCPDAT83
FDAT_ACT=FP84
BAS(#CP_PARAMS,1)
LIN XP84 C_DIS C_DIS
:ENDFOLD
:FOLD LIN P85 CONT Vel=1 m/s CPDAT84 Tool[10]:b1 Base[14]:b1;% {PE}%R 8.3.44,%MKUKATPBASIS,%CMOVE,%VLIN,%P
1:LIN, 2:P85, 3:C_DIS C_DIS, 5:1, 7:CPDAT84
$BWDSTART=FALSE

```



```

LDAT_ACT=LCPDAT84
FDAT_ACT=FP85
BAS(#CP_PARAMS,1)
LIN XP85 C_DIS C_DIS
:ENDFOLD
:FOLD LIN P86 CONT Vel=1 m/s CPDAT85 Tool[10]:b1 Base[14]:b1;% {PE}%R 8.3.44,%MKUKATPBASIS,%CMOVE,%VLIN,%P
1:LIN, 2:P86, 3:C_DIS C_DIS, 5:1, 7:CPDAT85
$BWDSTART=FALSE
LDAT_ACT=LCPDAT85
FDAT_ACT=FP86
BAS(#CP_PARAMS,1)
LIN XP86 C_DIS C_DIS
:ENDFOLD
:FOLD LIN P87 CONT Vel=1 m/s CPDAT86 Tool[10]:b1 Base[14]:b1;% {PE}%R 8.3.44,%MKUKATPBASIS,%CMOVE,%VLIN,%P
1:LIN, 2:P87, 3:C_DIS C_DIS, 5:1, 7:CPDAT86
$BWDSTART=FALSE
LDAT_ACT=LCPDAT86
FDAT_ACT=FP87
BAS(#CP_PARAMS,1)
LIN XP87 C_DIS C_DIS
:ENDFOLD
:FOLD LIN P88 CONT Vel=1 m/s CPDAT87 Tool[10]:b1 Base[14]:b1;% {PE}%R 8.3.44,%MKUKATPBASIS,%CMOVE,%VLIN,%P
1:LIN, 2:P88, 3:C_DIS C_DIS, 5:1, 7:CPDAT87
$BWDSTART=FALSE
LDAT_ACT=LCPDAT87
FDAT_ACT=FP88
BAS(#CP_PARAMS,1)
LIN XP88 C_DIS C_DIS
:ENDFOLD
:FOLD LIN P89 CONT Vel=1 m/s CPDAT88 Tool[10]:b1 Base[14]:b1;% {PE}%R 8.3.44,%MKUKATPBASIS,%CMOVE,%VLIN,%P
1:LIN, 2:P89, 3:C_DIS C_DIS, 5:1, 7:CPDAT88
$BWDSTART=FALSE
LDAT_ACT=LCPDAT88
FDAT_ACT=FP89
BAS(#CP_PARAMS,1)
LIN XP89 C_DIS C_DIS
:ENDFOLD
:FOLD LIN P90 CONT Vel=1 m/s CPDAT89 Tool[10]:b1 Base[14]:b1;% {PE}%R 8.3.44,%MKUKATPBASIS,%CMOVE,%VLIN,%P
1:LIN, 2:P90, 3:C_DIS C_DIS, 5:1, 7:CPDAT89
$BWDSTART=FALSE
LDAT_ACT=LCPDAT89
FDAT_ACT=FP90
BAS(#CP_PARAMS,1)
LIN XP90 C_DIS C_DIS
:ENDFOLD
:FOLD LIN P91 CONT Vel=1 m/s CPDAT90 Tool[10]:b1 Base[14]:b1;% {PE}%R 8.3.44,%MKUKATPBASIS,%CMOVE,%VLIN,%P
1:LIN, 2:P91, 3:C_DIS C_DIS, 5:1, 7:CPDAT90
$BWDSTART=FALSE
LDAT_ACT=LCPDAT90
FDAT_ACT=FP91
BAS(#CP_PARAMS,1)
LIN XP91 C_DIS C_DIS
:ENDFOLD
:FOLD LIN P92 CONT Vel=1 m/s CPDAT91 Tool[10]:b1 Base[14]:b1;% {PE}%R 8.3.44,%MKUKATPBASIS,%CMOVE,%VLIN,%P
1:LIN, 2:P92, 3:C_DIS C_DIS, 5:1, 7:CPDAT91
$BWDSTART=FALSE
LDAT_ACT=LCPDAT91
FDAT_ACT=FP92
BAS(#CP_PARAMS,1)
LIN XP92 C_DIS C_DIS
:ENDFOLD
:FOLD LIN P93 CONT Vel=1 m/s CPDAT92 Tool[10]:b1 Base[14]:b1;% {PE}%R 8.3.44,%MKUKATPBASIS,%CMOVE,%VLIN,%P
1:LIN, 2:P93, 3:C_DIS C_DIS, 5:1, 7:CPDAT92
$BWDSTART=FALSE
LDAT_ACT=LCPDAT92
FDAT_ACT=FP93
BAS(#CP_PARAMS,1)
LIN XP93 C_DIS C_DIS
:ENDFOLD
:FOLD LIN P94 CONT Vel=1 m/s CPDAT93 Tool[10]:b1 Base[14]:b1;% {PE}%R 8.3.44,%MKUKATPBASIS,%CMOVE,%VLIN,%P
1:LIN, 2:P94, 3:C_DIS C_DIS, 5:1, 7:CPDAT93
$BWDSTART=FALSE
LDAT_ACT=LCPDAT93
FDAT_ACT=FP94
BAS(#CP_PARAMS,1)

```

```

LIN XP94 C_DIS C_DIS
:ENDFOLD
:FOLD LIN P95 CONT Vel=1 m/s CPDAT94 Tool[10]:b1 Base[14]:b1;% {PE}%R 8.3.44,%MKUKATPBASIS,%CMOVE,%VLIN,%P
1:LIN, 2:P95, 3:C_DIS C_DIS, 5:1, 7:CPDAT94
$BWDSTART=FALSE
LDAT_ACT=LCPDAT94
FDAT_ACT=FP95
BAS(#CP_PARAMS,1)
LIN XP95 C_DIS C_DIS
:ENDFOLD
:FOLD LIN P96 CONT Vel=1 m/s CPDAT95 Tool[10]:b1 Base[14]:b1;% {PE}%R 8.3.44,%MKUKATPBASIS,%CMOVE,%VLIN,%P
1:LIN, 2:P96, 3:C_DIS C_DIS, 5:1, 7:CPDAT95
$BWDSTART=FALSE
LDAT_ACT=LCPDAT95
FDAT_ACT=FP96
BAS(#CP_PARAMS,1)
LIN XP96 C_DIS C_DIS
:ENDFOLD
:FOLD LIN P97 CONT Vel=1 m/s CPDAT96 Tool[10]:b1 Base[14]:b1;% {PE}%R 8.3.44,%MKUKATPBASIS,%CMOVE,%VLIN,%P
1:LIN, 2:P97, 3:C_DIS C_DIS, 5:1, 7:CPDAT96
$BWDSTART=FALSE
LDAT_ACT=LCPDAT96
FDAT_ACT=FP97
BAS(#CP_PARAMS,1)
LIN XP97 C_DIS C_DIS
:ENDFOLD
:FOLD LIN P98 CONT Vel=1 m/s CPDAT97 Tool[10]:b1 Base[14]:b1;% {PE}%R 8.3.44,%MKUKATPBASIS,%CMOVE,%VLIN,%P
1:LIN, 2:P98, 3:C_DIS C_DIS, 5:1, 7:CPDAT97
$BWDSTART=FALSE
LDAT_ACT=LCPDAT97
FDAT_ACT=FP98
BAS(#CP_PARAMS,1)
LIN XP98 C_DIS C_DIS
:ENDFOLD
:FOLD LIN P99 CONT Vel=1 m/s CPDAT98 Tool[10]:b1 Base[14]:b1;% {PE}%R 8.3.44,%MKUKATPBASIS,%CMOVE,%VLIN,%P
1:LIN, 2:P99, 3:C_DIS C_DIS, 5:1, 7:CPDAT98
$BWDSTART=FALSE
LDAT_ACT=LCPDAT98
FDAT_ACT=FP99
BAS(#CP_PARAMS,1)
LIN XP99 C_DIS C_DIS
:ENDFOLD
:FOLD LIN P100 CONT Vel=1 m/s CPDAT99 Tool[10]:b1 Base[14]:b1;% {PE}%R 8.3.44,%MKUKATPBASIS,%CMOVE,%VLIN,%P
1:LIN, 2:P100, 3:C_DIS C_DIS, 5:1, 7:CPDAT99
$BWDSTART=FALSE
LDAT_ACT=LCPDAT99
FDAT_ACT=FP100
BAS(#CP_PARAMS,1)
LIN XP100 C_DIS C_DIS
:ENDFOLD
:FOLD LIN P101 CONT Vel=1 m/s CPDAT100 Tool[10]:b1 Base[14]:b1;% {PE}%R 8.3.44,%MKUKATPBASIS,%CMOVE,%VLIN,%P
1:LIN, 2:P101, 3:C_DIS C_DIS, 5:1, 7:CPDAT100
$BWDSTART=FALSE
LDAT_ACT=LCPDAT100
FDAT_ACT=FP101
BAS(#CP_PARAMS,1)
LIN XP101 C_DIS C_DIS
:ENDFOLD
:FOLD LIN P102 CONT Vel=1 m/s CPDAT101 Tool[10]:b1 Base[14]:b1;% {PE}%R 8.3.44,%MKUKATPBASIS,%CMOVE,%VLIN,%P
1:LIN, 2:P102, 3:C_DIS C_DIS, 5:1, 7:CPDAT101
$BWDSTART=FALSE
LDAT_ACT=LCPDAT101
FDAT_ACT=FP102
BAS(#CP_PARAMS,1)
LIN XP102 C_DIS C_DIS
:ENDFOLD
:FOLD LIN P103 CONT Vel=1 m/s CPDAT102 Tool[10]:b1 Base[14]:b1;% {PE}%R 8.3.44,%MKUKATPBASIS,%CMOVE,%VLIN,%P
1:LIN, 2:P103, 3:C_DIS C_DIS, 5:1, 7:CPDAT102
$BWDSTART=FALSE
LDAT_ACT=LCPDAT102
FDAT_ACT=FP103
BAS(#CP_PARAMS,1)
LIN XP103 C_DIS C_DIS
:ENDFOLD

```

```
;FOLD LIN P104 CONT Vel=1 m/s CPDAT103 Tool[10]:b1 Base[14]:b1;% {PE}%R 8.3.44,%MKUKATPBASIS,%CMOVE,%VLIN,%P
1:LIN, 2:P104, 3:C_DIS C_DIS, 5:1, 7:CPDAT103
$BWDSTART=FALSE
LDAT_ACT=LCPDAT103
FDAT_ACT=FP104
BAS(#CP_PARAMS,1)
LIN XP104 C_DIS C_DIS
;ENDFOLD
;FOLD LIN P105 CONT Vel=1 m/s CPDAT104 Tool[10]:b1 Base[14]:b1;% {PE}%R 8.3.44,%MKUKATPBASIS,%CMOVE,%VLIN,%P
1:LIN, 2:P105, 3:C_DIS C_DIS, 5:1, 7:CPDAT104
$BWDSTART=FALSE
LDAT_ACT=LCPDAT104
FDAT_ACT=FP105
BAS(#CP_PARAMS,1)
LIN XP105 C_DIS C_DIS
;ENDFOLD
;FOLD LIN P106 CONT Vel=1 m/s CPDAT105 Tool[10]:b1 Base[14]:b1;% {PE}%R 8.3.44,%MKUKATPBASIS,%CMOVE,%VLIN,%P
1:LIN, 2:P106, 3:C_DIS C_DIS, 5:1, 7:CPDAT105
$BWDSTART=FALSE
LDAT_ACT=LCPDAT105
FDAT_ACT=FP106
BAS(#CP_PARAMS,1)
LIN XP106 C_DIS C_DIS
;ENDFOLD
;FOLD LIN P107 CONT Vel=1 m/s CPDAT106 Tool[10]:b1 Base[14]:b1;% {PE}%R 8.3.44,%MKUKATPBASIS,%CMOVE,%VLIN,%P
1:LIN, 2:P107, 3:C_DIS C_DIS, 5:1, 7:CPDAT106
$BWDSTART=FALSE
LDAT_ACT=LCPDAT106
FDAT_ACT=FP107
BAS(#CP_PARAMS,1)
LIN XP107 C_DIS C_DIS
;ENDFOLD
;FOLD LIN P108 CONT Vel=1 m/s CPDAT107 Tool[10]:b1 Base[14]:b1;% {PE}%R 8.3.44,%MKUKATPBASIS,%CMOVE,%VLIN,%P
1:LIN, 2:P108, 3:C_DIS C_DIS, 5:1, 7:CPDAT107
$BWDSTART=FALSE
LDAT_ACT=LCPDAT107
FDAT_ACT=FP108
BAS(#CP_PARAMS,1)
LIN XP108 C_DIS C_DIS
;ENDFOLD
;FOLD LIN P109 CONT Vel=1 m/s CPDAT108 Tool[10]:b1 Base[14]:b1;% {PE}%R 8.3.44,%MKUKATPBASIS,%CMOVE,%VLIN,%P
1:LIN, 2:P109, 3:C_DIS C_DIS, 5:1, 7:CPDAT108
$BWDSTART=FALSE
LDAT_ACT=LCPDAT108
FDAT_ACT=FP109
BAS(#CP_PARAMS,1)
LIN XP109 C_DIS C_DIS
;ENDFOLD
;FOLD LIN P110 CONT Vel=1 m/s CPDAT109 Tool[10]:b1 Base[14]:b1;% {PE}%R 8.3.44,%MKUKATPBASIS,%CMOVE,%VLIN,%P
1:LIN, 2:P110, 3:C_DIS C_DIS, 5:1, 7:CPDAT109
$BWDSTART=FALSE
LDAT_ACT=LCPDAT109
FDAT_ACT=FP110
BAS(#CP_PARAMS,1)
LIN XP110 C_DIS C_DIS
;ENDFOLD
ENDLOOP
END
```

Extensión .dat

```

&ACCESS RVP
&REL 175
&PARAM EDITMASK = *
&PARAM TEMPLATE = C:\KRC\Roboter\Template\vorgabe
DEFDAT pelton3
:FOLD EXTERNAL DECLARATIONS;% {PE}%MKUKATPBASIS,%CEXT,%VCOMMON,%P
:FOLD BASIS TECH EXT;% {PE}%MKUKATPBASIS,%CEXT,%VEXT,%P
EXT BAS (BAS_COMMAND :IN,REAL :IN)
DECL INT SUCCESS
:ENDFOLD (BASIS TECH EXT)
:FOLD USER EXT;% {E}%MKUKATPUSER,%CEXT,%VEXT,%P
:Make your modifications here

:ENDFOLD (USER EXT)
:ENDFOLD (EXTERNAL DECLARATIONS)
DECL BASIS_SUGG_T LAST_BASIS={POINT1[] "P123",POINT2[] "P123",CP_PARAMS[] "CPDAT122",PTP_PARAMS[] "PDAT1",CONT[] "C_DIS C_DIS",CP_VEL[] "1",PTP_VEL[] "100",SYNC_PARAMS[] "SYNCDAT",SPL_NAME[] "S0",A_PARAMS[] "ADATO"}
DECL E6POS XP1={X -887.927368,Y -946.831299,Z 596.597107,A 1.91744304,B 87.5199,C -165.420044,S 2,T 10,E1 0.0,E2 0.0,E3 0.0,E4 0.0,E5 0.0,E6 0.0}
DECL FDAT FP1={TOOL_NO 10,BASE_NO 14,IPO_FRAME #BASE,POINT2[] " ",TQ_STATE FALSE}
DECL LDAT LCPDAT1={VEL 100.000,ACC 100.000,APO_DIST 100.000,APO_MODE #CDIS,GEAR_JERK 50.0000,EXAX_IGN 0}
DECL E6POS XP2={X -534.573303,Y -420.671417,Z 325.696289,A -111.378609,B 86.9559631,C 29.8301353,S 2,T 10,E1 0.0,E2 0.0,E3 0.0,E4 0.0,E5 0.0,E6 0.0}
DECL FDAT FP2={TOOL_NO 10,BASE_NO 14,IPO_FRAME #BASE,POINT2[] " ",TQ_STATE FALSE}
DECL LDAT LCPDAT1={VEL 2.00000,ACC 100.000,APO_DIST 100.000,APO_FAC 50.0000,AXIS_VEL 100.000,AXIS_ACC 100.000,ORI_TYP #JOINT,CIRC_TYP #BASE,JERK_FAC 50.0000,GEAR_JERK 50.0000,EXAX_IGN 0}
DECL E6POS XP3={X -1078.09314,Y -120.208549,Z 619.537720,A 36.8889542,B 88.9764481,C 170.440277,S 2,T 10,E1 0.0,E2 0.0,E3 0.0,E4 0.0,E5 0.0,E6 0.0}
DECL FDAT FP3={TOOL_NO 10,BASE_NO 14,IPO_FRAME #BASE,POINT2[] " ",TQ_STATE FALSE}
DECL LDAT LCPDAT2={VEL 2.00000,ACC 100.000,APO_DIST 100.000,APO_FAC 50.0000,AXIS_VEL 100.000,AXIS_ACC 100.000,ORI_TYP #JOINT,CIRC_TYP #BASE,JERK_FAC 50.0000,GEAR_JERK 50.0000,EXAX_IGN 0}
DECL E6POS XP4={X -1085.68823,Y -117.416176,Z 564.769226,A 36.8889351,B 88.9764481,C 170.440247,S 2,T 10,E1 0.0,E2 0.0,E3 0.0,E4 0.0,E5 0.0,E6 0.0}
DECL FDAT FP4={TOOL_NO 10,BASE_NO 14,IPO_FRAME #BASE,POINT2[] " ",TQ_STATE FALSE}
DECL LDAT LCPDAT3={VEL 2.00000,ACC 100.000,APO_DIST 100.000,APO_FAC 50.0000,AXIS_VEL 100.000,AXIS_ACC 100.000,ORI_TYP #JOINT,CIRC_TYP #BASE,JERK_FAC 50.0000,GEAR_JERK 50.0000,EXAX_IGN 0}
DECL E6POS XP5={X -1087.82764,Y -117.384911,Z 461.266479,A 36.8889,B 88.9764481,C 170.440216,S 2,T 10,E1 0.0,E2 0.0,E3 0.0,E4 0.0,E5 0.0,E6 0.0}
DECL FDAT FP5={TOOL_NO 10,BASE_NO 14,IPO_FRAME #BASE,POINT2[] " ",TQ_STATE FALSE}
DECL LDAT LCPDAT4={VEL 2.00000,ACC 100.000,APO_DIST 100.000,APO_FAC 50.0000,AXIS_VEL 100.000,AXIS_ACC 100.000,ORI_TYP #JOINT,CIRC_TYP #BASE,JERK_FAC 50.0000,GEAR_JERK 50.0000,EXAX_IGN 0}
DECL E6POS XP6={X -1086.52734,Y -115.216957,Z 450.176025,A 36.8888779,B 88.9764481,C 170.440186,S 2,T 10,E1 0.0,E2 0.0,E3 0.0,E4 0.0,E5 0.0,E6 0.0}
DECL FDAT FP6={TOOL_NO 10,BASE_NO 14,IPO_FRAME #BASE,POINT2[] " ",TQ_STATE FALSE}
DECL LDAT LCPDAT5={VEL 2.00000,ACC 100.000,APO_DIST 100.000,APO_FAC 50.0000,AXIS_VEL 100.000,AXIS_ACC 100.000,ORI_TYP #JOINT,CIRC_TYP #BASE,JERK_FAC 50.0000,GEAR_JERK 50.0000,EXAX_IGN 0}
DECL E6POS XP7={X -1065.42822,Y -110.646759,Z 358.573,A 35.0310440,B 88.9688721,C 170.644455,S 2,T 10,E1 0.0,E2 0.0,E3 0.0,E4 0.0,E5 0.0,E6 0.0}
DECL FDAT FP7={TOOL_NO 10,BASE_NO 14,IPO_FRAME #BASE,POINT2[] " ",TQ_STATE FALSE}
DECL LDAT LCPDAT6={VEL 2.00000,ACC 100.000,APO_DIST 100.000,APO_FAC 50.0000,AXIS_VEL 100.000,AXIS_ACC 100.000,ORI_TYP #JOINT,CIRC_TYP #BASE,JERK_FAC 50.0000,GEAR_JERK 50.0000,EXAX_IGN 0}
DECL E6POS XP8={X -1100.48242,Y -82.2532120,Z 338.693268,A 38.3104553,B 88.9815750,C 170.298721,S 2,T 10,E1 0.0,E2 0.0,E3 0.0,E4 0.0,E5 0.0,E6 0.0}
DECL FDAT FP8={TOOL_NO 10,BASE_NO 14,IPO_FRAME #BASE,POINT2[] " ",TQ_STATE FALSE}
DECL LDAT LCPDAT7={VEL 2.00000,ACC 100.000,APO_DIST 100.000,APO_FAC 50.0000,AXIS_VEL 100.000,AXIS_ACC 100.000,ORI_TYP #JOINT,CIRC_TYP #BASE,JERK_FAC 50.0000,GEAR_JERK 50.0000,EXAX_IGN 0}
DECL E6POS XP9={X -1109.52930,Y -102.643143,Z 454.052643,A 38.3104553,B 88.9815674,C 170.298721,S 2,T 10,E1 0.0,E2 0.0,E3 0.0,E4 0.0,E5 0.0,E6 0.0}
DECL FDAT FP9={TOOL_NO 10,BASE_NO 14,IPO_FRAME #BASE,POINT2[] " ",TQ_STATE FALSE}
DECL LDAT LCPDAT8={VEL 2.00000,ACC 100.000,APO_DIST 100.000,APO_FAC 50.0000,AXIS_VEL 100.000,AXIS_ACC 100.000,ORI_TYP #JOINT,CIRC_TYP #BASE,JERK_FAC 50.0000,GEAR_JERK 50.0000,EXAX_IGN 0}
DECL E6POS XP10={X -1111.79883,Y -104.110413,Z 466.955597,A 38.3104439,B 88.9815674,C 170.298706,S 2,T 10,E1 0.0,E2 0.0,E3 0.0,E4 0.0,E5 0.0,E6 0.0}
DECL FDAT FP10={TOOL_NO 10,BASE_NO 14,IPO_FRAME #BASE,POINT2[] " ",TQ_STATE FALSE}
DECL LDAT LCPDAT9={VEL 2.00000,ACC 100.000,APO_DIST 100.000,APO_FAC 50.0000,AXIS_VEL 100.000,AXIS_ACC 100.000,ORI_TYP #JOINT,CIRC_TYP #BASE,JERK_FAC 50.0000,GEAR_JERK 50.0000,EXAX_IGN 0}
DECL E6POS XP11={X -1111.92957,Y -104.469955,Z 559.872559,A 38.3104248,B 88.9815674,C 170.298676,S 2,T 10,E1 0.0,E2 0.0,E3 0.0,E4 0.0,E5 0.0,E6 0.0}
DECL FDAT FP11={TOOL_NO 10,BASE_NO 14,IPO_FRAME #BASE,POINT2[] " ",TQ_STATE FALSE}
DECL LDAT LCPDAT10={VEL 2.00000,ACC 100.000,APO_DIST 100.000,APO_FAC 50.0000,AXIS_VEL 100.000,AXIS_ACC 100.000,ORI_TYP #JOINT,CIRC_TYP #BASE,JERK_FAC 50.0000,GEAR_JERK 50.0000,EXAX_IGN 0}

```

```

DECL E6POS XP12={X -1110.52576,Y -102.681427,Z 571.352722,A 38.3103905,B 88.9815674,C 170.298645,S 2,T 10,E1 0.0,E2 0.0,E3
0.0,E4 0.0,E5 0.0,E6 0.0}
DECL FDAT FP12={TOOL_NO 10,BASE_NO 14,IPO_FRAME #BASE,POINT2[] " ",TQ_STATE FALSE}
DECL LDAT LCPDAT11={VEL 2.00000,ACC 100.000,APO_DIST 100.000,APO_FAC 50.0000,AXIS_VEL 100.000,AXIS_ACC
100.000,ORI_TYP #JOINT,CIRC_TYP #BASE,JERK_FAC 50.0000,GEAR_JERK 50.0000,EXAX_IGN 0}
DECL E6POS XP13={X -1106.10059,Y -97.7631531,Z 580.714722,A 38.3166428,B 88.9809723,C 170.304718,S 2,T 10,E1 0.0,E2 0.0,E3
0.0,E4 0.0,E5 0.0,E6 0.0}
DECL FDAT FP13={TOOL_NO 10,BASE_NO 14,IPO_FRAME #BASE,POINT2[] " ",TQ_STATE FALSE}
DECL LDAT LCPDAT12={VEL 2.00000,ACC 100.000,APO_DIST 100.000,APO_FAC 50.0000,AXIS_VEL 100.000,AXIS_ACC
100.000,ORI_TYP #JOINT,CIRC_TYP #BASE,JERK_FAC 50.0000,GEAR_JERK 50.0000,EXAX_IGN 0}
DECL E6POS XP14={X -1106.23096,Y -97.7525787,Z 637.665649,A 37.7874794,B 88.9844513,C 169.776825,S 2,T 10,E1 0.0,E2 0.0,E3
0.0,E4 0.0,E5 0.0,E6 0.0}
DECL FDAT FP14={TOOL_NO 10,BASE_NO 14,IPO_FRAME #BASE,POINT2[] " ",TQ_STATE FALSE}
DECL LDAT LCPDAT13={VEL 2.00000,ACC 100.000,APO_DIST 100.000,APO_FAC 50.0000,AXIS_VEL 100.000,AXIS_ACC
100.000,ORI_TYP #JOINT,CIRC_TYP #BASE,JERK_FAC 50.0000,GEAR_JERK 50.0000,EXAX_IGN 0}
DECL E6POS XP15={X -1106.03882,Y -97.7917862,Z 637.520203,A 38.0708847,B 88.9628296,C -170.184586,S 2,T 10,E1 0.0,E2 0.0,E3
0.0,E4 0.0,E5 0.0,E6 0.0}
DECL FDAT FP15={TOOL_NO 10,BASE_NO 14,IPO_FRAME #BASE,POINT2[] " ",TQ_STATE FALSE}
DECL LDAT LCPDAT14={VEL 2.00000,ACC 100.000,APO_DIST 100.000,APO_FAC 50.0000,AXIS_VEL 100.000,AXIS_ACC
100.000,ORI_TYP #JOINT,CIRC_TYP #BASE,JERK_FAC 50.0000,GEAR_JERK 50.0000,EXAX_IGN 0}
DECL E6POS XP16={X -935.314,Y -259.262024,Z 732.871033,A 38.0649834,B 88.9591675,C -161.016449,S 2,T 10,E1 0.0,E2 0.0,E3
0.0,E4 0.0,E5 0.0,E6 0.0}
DECL FDAT FP16={TOOL_NO 10,BASE_NO 14,IPO_FRAME #BASE,POINT2[] " ",TQ_STATE FALSE}
DECL LDAT LCPDAT15={VEL 2.00000,ACC 100.000,APO_DIST 100.000,APO_FAC 50.0000,AXIS_VEL 100.000,AXIS_ACC
100.000,ORI_TYP #JOINT,CIRC_TYP #BASE,JERK_FAC 50.0000,GEAR_JERK 50.0000,EXAX_IGN 0}
DECL E6POS XP17={X -948.793335,Y -274.205109,Z 408.050354,A -159.124527,B 68.7416458,C 2.62374234,S 2,T 10,E1 0.0,E2 0.0,E3
0.0,E4 0.0,E5 0.0,E6 0.0}
DECL FDAT FP17={TOOL_NO 10,BASE_NO 14,IPO_FRAME #BASE,POINT2[] " ",TQ_STATE FALSE}
DECL LDAT LCPDAT16={VEL 2.00000,ACC 100.000,APO_DIST 100.000,APO_FAC 50.0000,AXIS_VEL 100.000,AXIS_ACC
100.000,ORI_TYP #JOINT,CIRC_TYP #BASE,JERK_FAC 50.0000,GEAR_JERK 50.0000,EXAX_IGN 0}
DECL E6POS XP18={X -951.588623,Y -275.271088,Z 400.360779,A -159.124527,B 68.7416458,C 2.62374306,S 2,T 10,E1 0.0,E2 0.0,E3
0.0,E4 0.0,E5 0.0,E6 0.0}
DECL FDAT FP18={TOOL_NO 10,BASE_NO 14,IPO_FRAME #BASE,POINT2[] " ",TQ_STATE FALSE}
DECL LDAT LCPDAT17={VEL 2.00000,ACC 100.000,APO_DIST 100.000,APO_FAC 50.0000,AXIS_VEL 100.000,AXIS_ACC
100.000,ORI_TYP #JOINT,CIRC_TYP #BASE,JERK_FAC 50.0000,GEAR_JERK 50.0000,EXAX_IGN 0}
DECL E6POS XP19={X -956.489258,Y -276.580811,Z 399.698303,A -159.124527,B 68.7416458,C 2.62374473,S 2,T 10,E1 0.0,E2 0.0,E3
0.0,E4 0.0,E5 0.0,E6 0.0}
DECL FDAT FP19={TOOL_NO 10,BASE_NO 14,IPO_FRAME #BASE,POINT2[] " ",TQ_STATE FALSE}
DECL LDAT LCPDAT18={VEL 2.00000,ACC 100.000,APO_DIST 100.000,APO_FAC 50.0000,AXIS_VEL 100.000,AXIS_ACC
100.000,ORI_TYP #JOINT,CIRC_TYP #BASE,JERK_FAC 50.0000,GEAR_JERK 50.0000,EXAX_IGN 0}
DECL E6POS XP20={X -968.925781,Y -282.051178,Z 394.851074,A -159.124512,B 68.7416458,C 2.62374592,S 2,T 10,E1 0.0,E2 0.0,E3
0.0,E4 0.0,E5 0.0,E6 0.0}
DECL FDAT FP20={TOOL_NO 10,BASE_NO 14,IPO_FRAME #BASE,POINT2[] " ",TQ_STATE FALSE}
DECL LDAT LCPDAT19={VEL 2.00000,ACC 100.000,APO_DIST 100.000,APO_FAC 50.0000,AXIS_VEL 100.000,AXIS_ACC
100.000,ORI_TYP #JOINT,CIRC_TYP #BASE,JERK_FAC 50.0000,GEAR_JERK 50.0000,EXAX_IGN 0}
DECL E6POS XP21={X -974.438721,Y -285.666626,Z 397.135742,A -158.885834,B 70.4819183,C 2.84749794,S 2,T 10,E1 0.0,E2 0.0,E3
0.0,E4 0.0,E5 0.0,E6 0.0}
DECL FDAT FP21={TOOL_NO 10,BASE_NO 14,IPO_FRAME #BASE,POINT2[] " ",TQ_STATE FALSE}
DECL LDAT LCPDAT20={VEL 2.00000,ACC 100.000,APO_DIST 100.000,APO_FAC 50.0000,AXIS_VEL 100.000,AXIS_ACC
100.000,ORI_TYP #JOINT,CIRC_TYP #BASE,JERK_FAC 50.0000,GEAR_JERK 50.0000,EXAX_IGN 0}
DECL E6POS XP22={X -971.345764,Y -284.656097,Z 395.983948,A -158.665253,B 71.8624878,C 3.05629635,S 2,T 10,E1 0.0,E2 0.0,E3
0.0,E4 0.0,E5 0.0,E6 0.0}
DECL FDAT FP22={TOOL_NO 10,BASE_NO 14,IPO_FRAME #BASE,POINT2[] " ",TQ_STATE FALSE}
DECL LDAT LCPDAT21={VEL 2.00000,ACC 100.000,APO_DIST 100.000,APO_FAC 50.0000,AXIS_VEL 100.000,AXIS_ACC
100.000,ORI_TYP #JOINT,CIRC_TYP #BASE,JERK_FAC 50.0000,GEAR_JERK 50.0000,EXAX_IGN 0}
DECL E6POS XP23={X -966.328613,Y -283.014404,Z 394.257416,A -158.290817,B 73.8170547,C 3.41412020,S 2,T 10,E1 0.0,E2 0.0,E3
0.0,E4 0.0,E5 0.0,E6 0.0}
DECL FDAT FP23={TOOL_NO 10,BASE_NO 14,IPO_FRAME #BASE,POINT2[] " ",TQ_STATE FALSE}
DECL LDAT LCPDAT22={VEL 2.00000,ACC 100.000,APO_DIST 100.000,APO_FAC 50.0000,AXIS_VEL 100.000,AXIS_ACC
100.000,ORI_TYP #JOINT,CIRC_TYP #BASE,JERK_FAC 50.0000,GEAR_JERK 50.0000,EXAX_IGN 0}
DECL E6POS XP24={X -959.060547,Y -280.631165,Z 392.041962,A -157.462738,B 76.9511,C 4.21568966,S 2,T 10,E1 0.0,E2 0.0,E3
0.0,E4 0.0,E5 0.0,E6 0.0}
DECL FDAT FP24={TOOL_NO 10,BASE_NO 14,IPO_FRAME #BASE,POINT2[] " ",TQ_STATE FALSE}
DECL LDAT LCPDAT23={VEL 2.00000,ACC 100.000,APO_DIST 100.000,APO_FAC 50.0000,AXIS_VEL 100.000,AXIS_ACC
100.000,ORI_TYP #JOINT,CIRC_TYP #BASE,JERK_FAC 50.0000,GEAR_JERK 50.0000,EXAX_IGN 0}
DECL E6POS XP25={X -953.591,Y -278.831787,Z 390.711243,A -156.217789,B 79.9090958,C 5.43575382,S 2,T 10,E1 0.0,E2 0.0,E3
0.0,E4 0.0,E5 0.0,E6 0.0}
DECL FDAT FP25={TOOL_NO 10,BASE_NO 14,IPO_FRAME #BASE,POINT2[] " ",TQ_STATE FALSE}
DECL LDAT LCPDAT24={VEL 2.00000,ACC 100.000,APO_DIST 100.000,APO_FAC 50.0000,AXIS_VEL 100.000,AXIS_ACC
100.000,ORI_TYP #JOINT,CIRC_TYP #BASE,JERK_FAC 50.0000,GEAR_JERK 50.0000,EXAX_IGN 0}
DECL E6POS XP26={X -944.840271,Y -274.925537,Z 389.245026,A -153.008514,B 83.6373215,C 8.61367416,S 2,T 10,E1 0.0,E2 0.0,E3
0.0,E4 0.0,E5 0.0,E6 0.0}
DECL FDAT FP26={TOOL_NO 10,BASE_NO 14,IPO_FRAME #BASE,POINT2[] " ",TQ_STATE FALSE}
DECL LDAT LCPDAT25={VEL 2.00000,ACC 100.000,APO_DIST 100.000,APO_FAC 50.0000,AXIS_VEL 100.000,AXIS_ACC
100.000,ORI_TYP #JOINT,CIRC_TYP #BASE,JERK_FAC 50.0000,GEAR_JERK 50.0000,EXAX_IGN 0}

```

```

DECL E6POS XP27={X -923.039,Y -250.574493,Z 266.302917,A -153.010757,B 83.6374283,C 8.61242199,S 2,T 10,E1 0.0,E2 0.0,E3
0.0,E4 0.0,E5 0.0,E6 0.0}
DECL FDAT FP27={TOOL_NO 10,BASE_NO 14,IPO_FRAME #BASE,POINT2[] " ",TQ_STATE FALSE}
DECL LDAT LCPDAT26={VEL 2.00000,ACC 100.000,APO_DIST 100.000,APO_FAC 50.0000,AXIS_VEL 100.000,AXIS_ACC
100.000,ORI_TYP #JOINT,CIRC_TYP #BASE,JERK_FAC 50.0000,GEAR_JERK 50.0000,EXAX_IGN 0}
DECL E6POS XP28={X -906.724426,Y -384.504272,Z 312.058258,A -152.986160,B 83.6415100,C 24.7224121,S 2,T 10,E1 0.0,E2 0.0,E3
0.0,E4 0.0,E5 0.0,E6 0.0}
DECL FDAT FP28={TOOL_NO 10,BASE_NO 14,IPO_FRAME #BASE,POINT2[] " ",TQ_STATE FALSE}
DECL LDAT LCPDAT27={VEL 2.00000,ACC 100.000,APO_DIST 100.000,APO_FAC 50.0000,AXIS_VEL 100.000,AXIS_ACC
100.000,ORI_TYP #JOINT,CIRC_TYP #BASE,JERK_FAC 50.0000,GEAR_JERK 50.0000,EXAX_IGN 0}
DECL E6POS XP29={X -894.315918,Y -389.934875,Z 389.752197,A -152.988052,B 83.6415482,C 24.7210979,S 2,T 10,E1 0.0,E2 0.0,E3
0.0,E4 0.0,E5 0.0,E6 0.0}
DECL FDAT FP29={TOOL_NO 10,BASE_NO 14,IPO_FRAME #BASE,POINT2[] " ",TQ_STATE FALSE}
DECL LDAT LCPDAT28={VEL 2.00000,ACC 100.000,APO_DIST 100.000,APO_FAC 50.0000,AXIS_VEL 100.000,AXIS_ACC
100.000,ORI_TYP #JOINT,CIRC_TYP #BASE,JERK_FAC 50.0000,GEAR_JERK 50.0000,EXAX_IGN 0}
DECL E6POS XP30={X -902.982666,Y -389.815277,Z 400.235535,A -152.988022,B 83.6415482,C 24.7211094,S 2,T 10,E1 0.0,E2 0.0,E3
0.0,E4 0.0,E5 0.0,E6 0.0}
DECL FDAT FP30={TOOL_NO 10,BASE_NO 14,IPO_FRAME #BASE,POINT2[] " ",TQ_STATE FALSE}
DECL LDAT LCPDAT29={VEL 2.00000,ACC 100.000,APO_DIST 100.000,APO_FAC 50.0000,AXIS_VEL 100.000,AXIS_ACC
100.000,ORI_TYP #JOINT,CIRC_TYP #BASE,JERK_FAC 50.0000,GEAR_JERK 50.0000,EXAX_IGN 0}
DECL E6POS XP31={X -908.324524,Y -389.228973,Z 426.308838,A -152.988022,B 83.6415482,C 24.3503056,S 2,T 10,E1 0.0,E2 0.0,E3
0.0,E4 0.0,E5 0.0,E6 0.0}
DECL FDAT FP31={TOOL_NO 10,BASE_NO 14,IPO_FRAME #BASE,POINT2[] " ",TQ_STATE FALSE}
DECL LDAT LCPDAT30={VEL 2.00000,ACC 100.000,APO_DIST 100.000,APO_FAC 50.0000,AXIS_VEL 100.000,AXIS_ACC
100.000,ORI_TYP #JOINT,CIRC_TYP #BASE,JERK_FAC 50.0000,GEAR_JERK 50.0000,EXAX_IGN 0}
DECL E6POS XP32={X -909.401550,Y -388.483582,Z 447.999023,A -152.987961,B 83.6415482,C 24.3503437,S 2,T 10,E1 0.0,E2 0.0,E3
0.0,E4 0.0,E5 0.0,E6 0.0}
DECL FDAT FP32={TOOL_NO 10,BASE_NO 14,IPO_FRAME #BASE,POINT2[] " ",TQ_STATE FALSE}
DECL LDAT LCPDAT31={VEL 2.00000,ACC 100.000,APO_DIST 100.000,APO_FAC 50.0000,AXIS_VEL 100.000,AXIS_ACC
100.000,ORI_TYP #JOINT,CIRC_TYP #BASE,JERK_FAC 50.0000,GEAR_JERK 50.0000,EXAX_IGN 0}
DECL E6POS XP33={X -912.844849,Y -388.625671,Z 448.568420,A -162.863770,B 80.3017,C 14.5728159,S 2,T 10,E1 0.0,E2 0.0,E3
0.0,E4 0.0,E5 0.0,E6 0.0}
DECL FDAT FP33={TOOL_NO 10,BASE_NO 14,IPO_FRAME #BASE,POINT2[] " ",TQ_STATE FALSE}
DECL LDAT LCPDAT32={VEL 2.00000,ACC 100.000,APO_DIST 100.000,APO_FAC 50.0000,AXIS_VEL 100.000,AXIS_ACC
100.000,ORI_TYP #JOINT,CIRC_TYP #BASE,JERK_FAC 50.0000,GEAR_JERK 50.0000,EXAX_IGN 0}
DECL E6POS XP34={X -914.130310,Y -386.869385,Z 448.743744,A -165.840775,B 77.8821411,C 11.6489096,S 2,T 10,E1 0.0,E2 0.0,E3
0.0,E4 0.0,E5 0.0,E6 0.0}
DECL FDAT FP34={TOOL_NO 10,BASE_NO 14,IPO_FRAME #BASE,POINT2[] " ",TQ_STATE FALSE}
DECL LDAT LCPDAT33={VEL 2.00000,ACC 100.000,APO_DIST 100.000,APO_FAC 50.0000,AXIS_VEL 100.000,AXIS_ACC
100.000,ORI_TYP #JOINT,CIRC_TYP #BASE,JERK_FAC 50.0000,GEAR_JERK 50.0000,EXAX_IGN 0}
DECL E6POS XP35={X -907.203064,Y -383.261444,Z 447.008820,A -167.666428,B 75.6853,C 10.0163851,S 2,T 10,E1 0.0,E2 0.0,E3
0.0,E4 0.0,E5 0.0,E6 0.0}
DECL FDAT FP35={TOOL_NO 10,BASE_NO 14,IPO_FRAME #BASE,POINT2[] " ",TQ_STATE FALSE}
DECL LDAT LCPDAT34={VEL 2.00000,ACC 100.000,APO_DIST 100.000,APO_FAC 50.0000,AXIS_VEL 100.000,AXIS_ACC
100.000,ORI_TYP #JOINT,CIRC_TYP #BASE,JERK_FAC 50.0000,GEAR_JERK 50.0000,EXAX_IGN 0}
DECL E6POS XP36={X -899.180542,Y -379.183685,Z 444.786682,A -168.064331,B 75.1058578,C 9.63132095,S 2,T 10,E1 0.0,E2 0.0,E3
0.0,E4 0.0,E5 0.0,E6 0.0}
DECL FDAT FP36={TOOL_NO 10,BASE_NO 14,IPO_FRAME #BASE,POINT2[] " ",TQ_STATE FALSE}
DECL LDAT LCPDAT35={VEL 2.00000,ACC 100.000,APO_DIST 100.000,APO_FAC 50.0000,AXIS_VEL 100.000,AXIS_ACC
100.000,ORI_TYP #JOINT,CIRC_TYP #BASE,JERK_FAC 50.0000,GEAR_JERK 50.0000,EXAX_IGN 0}
DECL E6POS XP37={X -882.934753,Y -374.697357,Z 440.269806,A -169.009201,B 74.2224731,C 8.72010136,S 2,T 10,E1 0.0,E2 0.0,E3
0.0,E4 0.0,E5 0.0,E6 0.0}
DECL FDAT FP37={TOOL_NO 10,BASE_NO 14,IPO_FRAME #BASE,POINT2[] " ",TQ_STATE FALSE}
DECL LDAT LCPDAT36={VEL 2.00000,ACC 100.000,APO_DIST 100.000,APO_FAC 50.0000,AXIS_VEL 100.000,AXIS_ACC
100.000,ORI_TYP #JOINT,CIRC_TYP #BASE,JERK_FAC 50.0000,GEAR_JERK 50.0000,EXAX_IGN 0}
DECL E6POS XP38={X -876.612183,Y -374.483765,Z 438.504608,A -169.485413,B 73.3313293,C 8.26283550,S 2,T 10,E1 0.0,E2 0.0,E3
0.0,E4 0.0,E5 0.0,E6 0.0}
DECL FDAT FP38={TOOL_NO 10,BASE_NO 14,IPO_FRAME #BASE,POINT2[] " ",TQ_STATE FALSE}
DECL LDAT LCPDAT37={VEL 2.00000,ACC 100.000,APO_DIST 100.000,APO_FAC 50.0000,AXIS_VEL 100.000,AXIS_ACC
100.000,ORI_TYP #JOINT,CIRC_TYP #BASE,JERK_FAC 50.0000,GEAR_JERK 50.0000,EXAX_IGN 0}
DECL E6POS XP39={X -839.516,Y -367.803223,Z 559.578613,A -169.485535,B 73.3313293,C 8.26279545,S 2,T 10,E1 0.0,E2 0.0,E3
0.0,E4 0.0,E5 0.0,E6 0.0}
DECL FDAT FP39={TOOL_NO 10,BASE_NO 14,IPO_FRAME #BASE,POINT2[] " ",TQ_STATE FALSE}
DECL LDAT LCPDAT38={VEL 2.00000,ACC 100.000,APO_DIST 100.000,APO_FAC 50.0000,AXIS_VEL 100.000,AXIS_ACC
100.000,ORI_TYP #JOINT,CIRC_TYP #BASE,JERK_FAC 50.0000,GEAR_JERK 50.0000,EXAX_IGN 0}
DECL E6POS XP40={X -947.141846,Y -807.211731,Z 595.642578,A 147.374741,B 79.5138474,C 23.8043423,S 2,T 10,E1 0.0,E2 0.0,E3
0.0,E4 0.0,E5 0.0,E6 0.0}
DECL FDAT FP40={TOOL_NO 10,BASE_NO 14,IPO_FRAME #BASE,POINT2[] " ",TQ_STATE FALSE}
DECL LDAT LCPDAT39={VEL 2.00000,ACC 100.000,APO_DIST 100.000,APO_FAC 50.0000,AXIS_VEL 100.000,AXIS_ACC
100.000,ORI_TYP #JOINT,CIRC_TYP #BASE,JERK_FAC 50.0000,GEAR_JERK 50.0000,EXAX_IGN 0}
DECL E6POS XP41={X -995.335388,Y -126.065819,Z 320.161621,A -111.302368,B 86.9543076,C 29.9094753,S 2,T 10,E1 0.0,E2 0.0,E3
0.0,E4 0.0,E5 0.0,E6 0.0}
DECL FDAT FP41={TOOL_NO 10,BASE_NO 14,IPO_FRAME #BASE,POINT2[] " ",TQ_STATE FALSE}
DECL LDAT LCPDAT40={VEL 2.00000,ACC 100.000,APO_DIST 100.000,APO_FAC 50.0000,AXIS_VEL 100.000,AXIS_ACC
100.000,ORI_TYP #JOINT,CIRC_TYP #BASE,JERK_FAC 50.0000,GEAR_JERK 50.0000,EXAX_IGN 0}

```

```

DECL E6POS XP42={X -1043.63354,Y -154.865036,Z 400.398071,A -122.211861,B 85.3378601,C 19.0234203,S 2,T 10,E1 0.0,E2 0.0,E3
0.0,E4 0.0,E5 0.0,E6 0.0}
DECL FDAT FP42={TOOL_NO 10,BASE_NO 14,IPO_FRAME #BASE,POINT2[] " ",TQ_STATE FALSE}
DECL LDAT LCPDAT41={VEL 2.00000,ACC 100.000,APO_DIST 100.000,APO_FAC 50.0000,AXIS_VEL 100.000,AXIS_ACC
100.000,ORI_TYP #JOINT,CIRC_TYP #BASE,JERK_FAC 50.0000,GEAR_JERK 50.0000,EXAX_IGN 0}
DECL E6POS XP43={X -1048.44153,Y -158.707581,Z 401.172424,A -129.288376,B 82.6692276,C 11.9836378,S 2,T 10,E1 0.0,E2 0.0,E3
0.0,E4 0.0,E5 0.0,E6 0.0}
DECL FDAT FP43={TOOL_NO 10,BASE_NO 14,IPO_FRAME #BASE,POINT2[] " ",TQ_STATE FALSE}
DECL LDAT LCPDAT42={VEL 2.00000,ACC 100.000,APO_DIST 100.000,APO_FAC 50.0000,AXIS_VEL 100.000,AXIS_ACC
100.000,ORI_TYP #JOINT,CIRC_TYP #BASE,JERK_FAC 50.0000,GEAR_JERK 50.0000,EXAX_IGN 0}
DECL E6POS XP44={X -1049.02844,Y -157.734589,Z 443.658722,A -129.288376,B 82.6692276,C 11.9836397,S 2,T 10,E1 0.0,E2 0.0,E3
0.0,E4 0.0,E5 0.0,E6 0.0}
DECL FDAT FP44={TOOL_NO 10,BASE_NO 14,IPO_FRAME #BASE,POINT2[] " ",TQ_STATE FALSE}
DECL LDAT LCPDAT43={VEL 2.00000,ACC 100.000,APO_DIST 100.000,APO_FAC 50.0000,AXIS_VEL 100.000,AXIS_ACC
100.000,ORI_TYP #JOINT,CIRC_TYP #BASE,JERK_FAC 50.0000,GEAR_JERK 50.0000,EXAX_IGN 0}
DECL E6POS XP45={X -1053.83081,Y -161.559418,Z 444.818115,A -133.192825,B 79.1975632,C 8.12620068,S 2,T 10,E1 0.0,E2 0.0,E3
0.0,E4 0.0,E5 0.0,E6 0.0}
DECL FDAT FP45={TOOL_NO 10,BASE_NO 14,IPO_FRAME #BASE,POINT2[] " ",TQ_STATE FALSE}
DECL LDAT LCPDAT44={VEL 2.00000,ACC 100.000,APO_DIST 100.000,APO_FAC 50.0000,AXIS_VEL 100.000,AXIS_ACC
100.000,ORI_TYP #JOINT,CIRC_TYP #BASE,JERK_FAC 50.0000,GEAR_JERK 50.0000,EXAX_IGN 0}
DECL E6POS XP46={X -1055.55811,Y -164.695313,Z 445.648773,A -134.873672,B 76.4290390,C 6.48276234,S 2,T 10,E1 0.0,E2 0.0,E3
0.0,E4 0.0,E5 0.0,E6 0.0}
DECL FDAT FP46={TOOL_NO 10,BASE_NO 14,IPO_FRAME #BASE,POINT2[] " ",TQ_STATE FALSE}
DECL LDAT LCPDAT45={VEL 2.00000,ACC 100.000,APO_DIST 100.000,APO_FAC 50.0000,AXIS_VEL 100.000,AXIS_ACC
100.000,ORI_TYP #JOINT,CIRC_TYP #BASE,JERK_FAC 50.0000,GEAR_JERK 50.0000,EXAX_IGN 0}
DECL E6POS XP47={X -1052.80127,Y -163.239777,Z 444.908905,A -135.382477,B 75.2914429,C 5.98933411,S 2,T 10,E1 0.0,E2 0.0,E3
0.0,E4 0.0,E5 0.0,E6 0.0}
DECL FDAT FP47={TOOL_NO 10,BASE_NO 14,IPO_FRAME #BASE,POINT2[] " ",TQ_STATE FALSE}
DECL LDAT LCPDAT46={VEL 2.00000,ACC 100.000,APO_DIST 100.000,APO_FAC 50.0000,AXIS_VEL 100.000,AXIS_ACC
100.000,ORI_TYP #JOINT,CIRC_TYP #BASE,JERK_FAC 50.0000,GEAR_JERK 50.0000,EXAX_IGN 0}
DECL E6POS XP48={X -1045.46094,Y -159.610840,Z 442.650665,A -135.950592,B 73.0549545,C 5.44130754,S 2,T 10,E1 0.0,E2 0.0,E3
0.0,E4 0.0,E5 0.0,E6 0.0}
DECL FDAT FP48={TOOL_NO 10,BASE_NO 14,IPO_FRAME #BASE,POINT2[] " ",TQ_STATE FALSE}
DECL LDAT LCPDAT47={VEL 2.00000,ACC 100.000,APO_DIST 100.000,APO_FAC 50.0000,AXIS_VEL 100.000,AXIS_ACC
100.000,ORI_TYP #JOINT,CIRC_TYP #BASE,JERK_FAC 50.0000,GEAR_JERK 50.0000,EXAX_IGN 0}
DECL E6POS XP49={X -1020.15204,Y -135.128143,Z 558.222900,A -135.950592,B 73.0549545,C 5.44130754,S 2,T 10,E1 0.0,E2 0.0,E3
0.0,E4 0.0,E5 0.0,E6 0.0}
DECL FDAT FP49={TOOL_NO 10,BASE_NO 14,IPO_FRAME #BASE,POINT2[] " ",TQ_STATE FALSE}
DECL LDAT LCPDAT48={VEL 2.00000,ACC 100.000,APO_DIST 100.000,APO_FAC 50.0000,AXIS_VEL 100.000,AXIS_ACC
100.000,ORI_TYP #JOINT,CIRC_TYP #BASE,JERK_FAC 50.0000,GEAR_JERK 50.0000,EXAX_IGN 0}
DECL E6POS XP50={X -948.602966,Y -265.819885,Z 557.303284,A -154.393066,B 67.7244873,C 4.74446917,S 2,T 10,E1 0.0,E2 0.0,E3
0.0,E4 0.0,E5 0.0,E6 0.0}
DECL FDAT FP50={TOOL_NO 10,BASE_NO 14,IPO_FRAME #BASE,POINT2[] " ",TQ_STATE FALSE}
DECL LDAT LCPDAT49={VEL 2.00000,ACC 100.000,APO_DIST 100.000,APO_FAC 50.0000,AXIS_VEL 100.000,AXIS_ACC
100.000,ORI_TYP #JOINT,CIRC_TYP #BASE,JERK_FAC 50.0000,GEAR_JERK 50.0000,EXAX_IGN 0}
DECL E6POS XP51={X -980.115723,Y -269.074158,Z 359.096222,A -155.240433,B 63.0980186,C 3.97339845,S 2,T 10,E1 0.0,E2 0.0,E3
0.0,E4 0.0,E5 0.0,E6 0.0}
DECL FDAT FP51={TOOL_NO 10,BASE_NO 14,IPO_FRAME #BASE,POINT2[] " ",TQ_STATE FALSE}
DECL LDAT LCPDAT50={VEL 2.00000,ACC 100.000,APO_DIST 100.000,APO_FAC 50.0000,AXIS_VEL 100.000,AXIS_ACC
100.000,ORI_TYP #JOINT,CIRC_TYP #BASE,JERK_FAC 50.0000,GEAR_JERK 50.0000,EXAX_IGN 0}
DECL E6POS XP52={X -976.998718,Y -268.008820,Z 354.797699,A -155.240433,B 63.0980186,C 3.97339869,S 2,T 10,E1 0.0,E2 0.0,E3
0.0,E4 0.0,E5 0.0,E6 0.0}
DECL FDAT FP52={TOOL_NO 10,BASE_NO 14,IPO_FRAME #BASE,POINT2[] " ",TQ_STATE FALSE}
DECL LDAT LCPDAT51={VEL 2.00000,ACC 100.000,APO_DIST 100.000,APO_FAC 50.0000,AXIS_VEL 100.000,AXIS_ACC
100.000,ORI_TYP #JOINT,CIRC_TYP #BASE,JERK_FAC 50.0000,GEAR_JERK 50.0000,EXAX_IGN 0}
DECL E6POS XP53={X -986.673462,Y -273.851929,Z 360.371796,A -155.106873,B 63.9426422,C 4.09295273,S 2,T 10,E1 0.0,E2 0.0,E3
0.0,E4 0.0,E5 0.0,E6 0.0}
DECL FDAT FP53={TOOL_NO 10,BASE_NO 14,IPO_FRAME #BASE,POINT2[] " ",TQ_STATE FALSE}
DECL LDAT LCPDAT52={VEL 2.00000,ACC 100.000,APO_DIST 100.000,APO_FAC 50.0000,AXIS_VEL 100.000,AXIS_ACC
100.000,ORI_TYP #JOINT,CIRC_TYP #BASE,JERK_FAC 50.0000,GEAR_JERK 50.0000,EXAX_IGN 0}
DECL E6POS XP54={X -994.710876,Y -278.333069,Z 364.445496,A -154.731018,B 66.0729828,C 4.43368101,S 2,T 10,E1 0.0,E2 0.0,E3
0.0,E4 0.0,E5 0.0,E6 0.0}
DECL FDAT FP54={TOOL_NO 10,BASE_NO 14,IPO_FRAME #BASE,POINT2[] " ",TQ_STATE FALSE}
DECL LDAT LCPDAT53={VEL 2.00000,ACC 100.000,APO_DIST 100.000,APO_FAC 50.0000,AXIS_VEL 100.000,AXIS_ACC
100.000,ORI_TYP #JOINT,CIRC_TYP #BASE,JERK_FAC 50.0000,GEAR_JERK 50.0000,EXAX_IGN 0}
DECL E6POS XP55={X -993.604187,Y -277.922699,Z 363.873505,A -154.526245,B 67.1005173,C 4.62159681,S 2,T 10,E1 0.0,E2 0.0,E3
0.0,E4 0.0,E5 0.0,E6 0.0}
DECL FDAT FP55={TOOL_NO 10,BASE_NO 14,IPO_FRAME #BASE,POINT2[] " ",TQ_STATE FALSE}
DECL LDAT LCPDAT54={VEL 2.00000,ACC 100.000,APO_DIST 100.000,APO_FAC 50.0000,AXIS_VEL 100.000,AXIS_ACC
100.000,ORI_TYP #JOINT,CIRC_TYP #BASE,JERK_FAC 50.0000,GEAR_JERK 50.0000,EXAX_IGN 0}
DECL E6POS XP56={X -987.594055,Y -275.680542,Z 361.174255,A -154.100143,B 68.9901657,C 5.01685381,S 2,T 10,E1 0.0,E2 0.0,E3
0.0,E4 0.0,E5 0.0,E6 0.0}
DECL FDAT FP56={TOOL_NO 10,BASE_NO 14,IPO_FRAME #BASE,POINT2[] " ",TQ_STATE FALSE}
DECL LDAT LCPDAT55={VEL 2.00000,ACC 100.000,APO_DIST 100.000,APO_FAC 50.0000,AXIS_VEL 100.000,AXIS_ACC
100.000,ORI_TYP #JOINT,CIRC_TYP #BASE,JERK_FAC 50.0000,GEAR_JERK 50.0000,EXAX_IGN 0}

```

```

DECL E6POS XP57={X -978.665833,Y -272.337494,Z 357.528870,A -153.215820,B 72.0878220,C 5.85095215,S 2,T 10,E1 0.0,E2 0.0,E3
0.0,E4 0.0,E5 0.0,E6 0.0}
DECL FDAT FP57={TOOL_NO 10,BASE_NO 14,IPO_FRAME #BASE,POINT2[] " ",TQ_STATE FALSE}
DECL LDAT LCPDAT56={VEL 2.00000,ACC 100.000,APO_DIST 100.000,APO_FAC 50.0000,AXIS_VEL 100.000,AXIS_ACC
100.000,ORI_TYP #JOINT,CIRC_TYP #BASE,JERK_FAC 50.0000,GEAR_JERK 50.0000,EXAX_IGN 0}
DECL E6POS XP58={X -969.382263,Y -268.841095,Z 354.340851,A -151.505981,B 76.0945129,C 7.49631262,S 2,T 10,E1 0.0,E2 0.0,E3
0.0,E4 0.0,E5 0.0,E6 0.0}
DECL FDAT FP58={TOOL_NO 10,BASE_NO 14,IPO_FRAME #BASE,POINT2[] " ",TQ_STATE FALSE}
DECL LDAT LCPDAT57={VEL 2.00000,ACC 100.000,APO_DIST 100.000,APO_FAC 50.0000,AXIS_VEL 100.000,AXIS_ACC
100.000,ORI_TYP #JOINT,CIRC_TYP #BASE,JERK_FAC 50.0000,GEAR_JERK 50.0000,EXAX_IGN 0}
DECL E6POS XP59={X -963.229065,Y -263.063263,Z 352.386810,A -149.747482,B 78.7068939,C 9.21292877,S 2,T 10,E1 0.0,E2 0.0,E3
0.0,E4 0.0,E5 0.0,E6 0.0}
DECL FDAT FP59={TOOL_NO 10,BASE_NO 14,IPO_FRAME #BASE,POINT2[] " ",TQ_STATE FALSE}
DECL LDAT LCPDAT58={VEL 2.00000,ACC 100.000,APO_DIST 100.000,APO_FAC 50.0000,AXIS_VEL 100.000,AXIS_ACC
100.000,ORI_TYP #JOINT,CIRC_TYP #BASE,JERK_FAC 50.0000,GEAR_JERK 50.0000,EXAX_IGN 0}
DECL E6POS XP60={X -889.631653,Y -234.554810,Z 350.596405,A -97.4611664,B 87.9523392,C 61.3392410,S 2,T 10,E1 0.0,E2 0.0,E3
0.0,E4 0.0,E5 0.0,E6 0.0}
DECL FDAT FP60={TOOL_NO 10,BASE_NO 14,IPO_FRAME #BASE,POINT2[] " ",TQ_STATE FALSE}
DECL LDAT LCPDAT59={VEL 2.00000,ACC 100.000,APO_DIST 100.000,APO_FAC 50.0000,AXIS_VEL 100.000,AXIS_ACC
100.000,ORI_TYP #JOINT,CIRC_TYP #BASE,JERK_FAC 50.0000,GEAR_JERK 50.0000,EXAX_IGN 0}
DECL E6POS XP61={X -895.079773,Y -667.712341,Z 365.923218,A -96.3040924,B 87.9178848,C 143.462524,S 2,T 10,E1 0.0,E2 0.0,E3
0.0,E4 0.0,E5 0.0,E6 0.0}
DECL FDAT FP61={TOOL_NO 10,BASE_NO 14,IPO_FRAME #BASE,POINT2[] " ",TQ_STATE FALSE}
DECL LDAT LCPDAT60={VEL 2.00000,ACC 100.000,APO_DIST 100.000,APO_FAC 50.0000,AXIS_VEL 100.000,AXIS_ACC
100.000,ORI_TYP #JOINT,CIRC_TYP #BASE,JERK_FAC 50.0000,GEAR_JERK 50.0000,EXAX_IGN 0}
DECL E6POS XP62={X -889.568420,Y -234.613159,Z 350.531036,A -96.9931793,B 87.9425278,C 100.027748,S 2,T 10,E1 0.0,E2 0.0,E3
0.0,E4 0.0,E5 0.0,E6 0.0}
DECL FDAT FP62={TOOL_NO 10,BASE_NO 14,IPO_FRAME #BASE,POINT2[] " ",TQ_STATE FALSE}
DECL LDAT LCPDAT61={VEL 2.00000,ACC 100.000,APO_DIST 100.000,APO_FAC 50.0000,AXIS_VEL 100.000,AXIS_ACC
100.000,ORI_TYP #JOINT,CIRC_TYP #BASE,JERK_FAC 50.0000,GEAR_JERK 50.0000,EXAX_IGN 0}
DECL E6POS XP63={X -851.119873,Y -576.693420,Z 362.554810,A -96.3202057,B 87.9245834,C 142.332016,S 2,T 10,E1 0.0,E2 0.0,E3
0.0,E4 0.0,E5 0.0,E6 0.0}
DECL FDAT FP63={TOOL_NO 10,BASE_NO 14,IPO_FRAME #BASE,POINT2[] " ",TQ_STATE FALSE}
DECL LDAT LCPDAT62={VEL 2.00000,ACC 100.000,APO_DIST 100.000,APO_FAC 50.0000,AXIS_VEL 100.000,AXIS_ACC
100.000,ORI_TYP #JOINT,CIRC_TYP #BASE,JERK_FAC 50.0000,GEAR_JERK 50.0000,EXAX_IGN 0}
DECL E6POS XP64={X -843.540588,Y -746.790,Z 368.633881,A -96.2597351,B 87.9241714,C 133.548676,S 2,T 10,E1 0.0,E2 0.0,E3
0.0,E4 0.0,E5 0.0,E6 0.0}
DECL FDAT FP64={TOOL_NO 10,BASE_NO 14,IPO_FRAME #BASE,POINT2[] " ",TQ_STATE FALSE}
DECL LDAT LCPDAT63={VEL 2.00000,ACC 100.000,APO_DIST 100.000,APO_FAC 50.0000,AXIS_VEL 100.000,AXIS_ACC
100.000,ORI_TYP #JOINT,CIRC_TYP #BASE,JERK_FAC 50.0000,GEAR_JERK 50.0000,EXAX_IGN 0}
DECL E6POS XP65={X -875.002075,Y -685.445,Z 366.920288,A -94.8788071,B 87.9030685,C 117.088234,S 2,T 10,E1 0.0,E2 0.0,E3
0.0,E4 0.0,E5 0.0,E6 0.0}
DECL FDAT FP65={TOOL_NO 10,BASE_NO 14,IPO_FRAME #BASE,POINT2[] " ",TQ_STATE FALSE}
DECL LDAT LCPDAT64={VEL 2.00000,ACC 100.000,APO_DIST 100.000,APO_FAC 50.0000,AXIS_VEL 100.000,AXIS_ACC
100.000,ORI_TYP #JOINT,CIRC_TYP #BASE,JERK_FAC 50.0000,GEAR_JERK 50.0000,EXAX_IGN 0}
DECL E6POS XP66={X -899.602295,Y -667.358093,Z 438.690094,A -94.9377747,B 87.9017105,C 117.019127,S 2,T 10,E1 0.0,E2 0.0,E3
0.0,E4 0.0,E5 0.0,E6 0.0}
DECL FDAT FP66={TOOL_NO 10,BASE_NO 14,IPO_FRAME #BASE,POINT2[] " ",TQ_STATE FALSE}
DECL LDAT LCPDAT65={VEL 2.00000,ACC 100.000,APO_DIST 100.000,APO_FAC 50.0000,AXIS_VEL 100.000,AXIS_ACC
100.000,ORI_TYP #JOINT,CIRC_TYP #BASE,JERK_FAC 50.0000,GEAR_JERK 50.0000,EXAX_IGN 0}
DECL E6POS XP67={X -899.591736,Y -667.235413,Z 442.050446,A -94.9377518,B 87.9017105,C 117.019157,S 2,T 10,E1 0.0,E2 0.0,E3
0.0,E4 0.0,E5 0.0,E6 0.0}
DECL FDAT FP67={TOOL_NO 10,BASE_NO 14,IPO_FRAME #BASE,POINT2[] " ",TQ_STATE FALSE}
DECL LDAT LCPDAT66={VEL 2.00000,ACC 100.000,APO_DIST 100.000,APO_FAC 50.0000,AXIS_VEL 100.000,AXIS_ACC
100.000,ORI_TYP #JOINT,CIRC_TYP #BASE,JERK_FAC 50.0000,GEAR_JERK 50.0000,EXAX_IGN 0}
DECL E6POS XP68={X -909.144348,Y -679.915039,Z 457.596588,A -50.1725349,B 67.6202774,C 164.859375,S 2,T 10,E1 0.0,E2 0.0,E3
0.0,E4 0.0,E5 0.0,E6 0.0}
DECL FDAT FP68={TOOL_NO 10,BASE_NO 14,IPO_FRAME #BASE,POINT2[] " ",TQ_STATE FALSE}
DECL LDAT LCPDAT67={VEL 2.00000,ACC 100.000,APO_DIST 100.000,APO_FAC 50.0000,AXIS_VEL 100.000,AXIS_ACC
100.000,ORI_TYP #JOINT,CIRC_TYP #BASE,JERK_FAC 50.0000,GEAR_JERK 50.0000,EXAX_IGN 0}
DECL E6POS XP69={X -926.238770,Y -679.294922,Z 592.337585,A -50.1714706,B 67.6208725,C 164.853745,S 2,T 10,E1 0.0,E2 0.0,E3
0.0,E4 0.0,E5 0.0,E6 0.0}
DECL FDAT FP69={TOOL_NO 10,BASE_NO 14,IPO_FRAME #BASE,POINT2[] " ",TQ_STATE FALSE}
DECL LDAT LCPDAT68={VEL 2.00000,ACC 100.000,APO_DIST 100.000,APO_FAC 50.0000,AXIS_VEL 100.000,AXIS_ACC
100.000,ORI_TYP #JOINT,CIRC_TYP #BASE,JERK_FAC 50.0000,GEAR_JERK 50.0000,EXAX_IGN 0}
DECL E6POS XP70={X -930.393250,Y -670.122559,Z 602.580872,A -50.1714363,B 67.6208496,C 164.853745,S 2,T 10,E1 0.0,E2 0.0,E3
0.0,E4 0.0,E5 0.0,E6 0.0}
DECL FDAT FP70={TOOL_NO 10,BASE_NO 14,IPO_FRAME #BASE,POINT2[] " ",TQ_STATE FALSE}
DECL LDAT LCPDAT69={VEL 2.00000,ACC 100.000,APO_DIST 100.000,APO_FAC 50.0000,AXIS_VEL 100.000,AXIS_ACC
100.000,ORI_TYP #JOINT,CIRC_TYP #BASE,JERK_FAC 50.0000,GEAR_JERK 50.0000,EXAX_IGN 0}
DECL E6POS XP71={X -937.518616,Y -665.035828,Z 599.472839,A -51.9339447,B 69.6947327,C 164.572647,S 2,T 10,E1 0.0,E2 0.0,E3
0.0,E4 0.0,E5 0.0,E6 0.0}
DECL FDAT FP71={TOOL_NO 10,BASE_NO 14,IPO_FRAME #BASE,POINT2[] " ",TQ_STATE FALSE}
DECL LDAT LCPDAT70={VEL 2.00000,ACC 100.000,APO_DIST 100.000,APO_FAC 50.0000,AXIS_VEL 100.000,AXIS_ACC
100.000,ORI_TYP #JOINT,CIRC_TYP #BASE,JERK_FAC 50.0000,GEAR_JERK 50.0000,EXAX_IGN 0}

```



```

DECL E6POS XP72={X -935.099915,Y -666.843628,Z 600.400879,A -54.0800972,B 72.0784302,C 163.485947,S 2,T 10,E1 0.0,E2 0.0,E3
0.0,E4 0.0,E5 0.0,E6 0.0}
DECL FDAT FP72={TOOL_NO 10,BASE_NO 14,IPO_FRAME #BASE,POINT2[] " ",TQ_STATE FALSE}
DECL LDAT LCPDAT71={VEL 2.00000,ACC 100.000,APO_DIST 100.000,APO_FAC 50.0000,AXIS_VEL 100.000,AXIS_ACC
100.000,ORI_TYP #JOINT,CIRC_TYP #BASE,JERK_FAC 50.0000,GEAR_JERK 50.0000,EXAX_IGN 0}
DECL E6POS XP73={X -925.015747,Y -674.480896,Z 603.954956,A -58.3092117,B 75.7465820,C 160.136398,S 2,T 10,E1 0.0,E2 0.0,E3
0.0,E4 0.0,E5 0.0,E6 0.0}
DECL FDAT FP73={TOOL_NO 10,BASE_NO 14,IPO_FRAME #BASE,POINT2[] " ",TQ_STATE FALSE}
DECL LDAT LCPDAT72={VEL 2.00000,ACC 100.000,APO_DIST 100.000,APO_FAC 50.0000,AXIS_VEL 100.000,AXIS_ACC
100.000,ORI_TYP #JOINT,CIRC_TYP #BASE,JERK_FAC 50.0000,GEAR_JERK 50.0000,EXAX_IGN 0}
DECL E6POS XP74={X -916.443237,Y -681.174255,Z 606.412720,A -65.8846436,B 79.4534607,C 152.199493,S 2,T 10,E1 0.0,E2 0.0,E3
0.0,E4 0.0,E5 0.0,E6 0.0}
DECL FDAT FP74={TOOL_NO 10,BASE_NO 14,IPO_FRAME #BASE,POINT2[] " ",TQ_STATE FALSE}
DECL LDAT LCPDAT73={VEL 2.00000,ACC 100.000,APO_DIST 100.000,APO_FAC 50.0000,AXIS_VEL 100.000,AXIS_ACC
100.000,ORI_TYP #JOINT,CIRC_TYP #BASE,JERK_FAC 50.0000,GEAR_JERK 50.0000,EXAX_IGN 0}
DECL E6POS XP75={X -910.027527,Y -686.147339,Z 607.750305,A -76.0528793,B 81.9215622,C 140.346252,S 2,T 10,E1 0.0,E2 0.0,E3
0.0,E4 0.0,E5 0.0,E6 0.0}
DECL FDAT FP75={TOOL_NO 10,BASE_NO 14,IPO_FRAME #BASE,POINT2[] " ",TQ_STATE FALSE}
DECL LDAT LCPDAT74={VEL 2.00000,ACC 100.000,APO_DIST 100.000,APO_FAC 50.0000,AXIS_VEL 100.000,AXIS_ACC
100.000,ORI_TYP #JOINT,CIRC_TYP #BASE,JERK_FAC 50.0000,GEAR_JERK 50.0000,EXAX_IGN 0}
DECL E6POS XP76={X -895.966125,Y -700.411072,Z 617.946411,A -76.0530930,B 81.9215851,C 140.345779,S 2,T 10,E1 0.0,E2 0.0,E3
0.0,E4 0.0,E5 0.0,E6 0.0}
DECL FDAT FP76={TOOL_NO 10,BASE_NO 14,IPO_FRAME #BASE,POINT2[] " ",TQ_STATE FALSE}
DECL LDAT LCPDAT75={VEL 2.00000,ACC 100.000,APO_DIST 100.000,APO_FAC 50.0000,AXIS_VEL 100.000,AXIS_ACC
100.000,ORI_TYP #JOINT,CIRC_TYP #BASE,JERK_FAC 50.0000,GEAR_JERK 50.0000,EXAX_IGN 0}
DECL E6POS XP77={X -900.686096,Y -681.394897,Z 756.094727,A -76.0451355,B 81.9210510,C 140.350021,S 2,T 10,E1 0.0,E2 0.0,E3
0.0,E4 0.0,E5 0.0,E6 0.0}
DECL FDAT FP77={TOOL_NO 10,BASE_NO 14,IPO_FRAME #BASE,POINT2[] " ",TQ_STATE FALSE}
DECL LDAT LCPDAT76={VEL 2.00000,ACC 100.000,APO_DIST 100.000,APO_FAC 50.0000,AXIS_VEL 100.000,AXIS_ACC
100.000,ORI_TYP #JOINT,CIRC_TYP #BASE,JERK_FAC 50.0000,GEAR_JERK 50.0000,EXAX_IGN 0}
DECL E6POS XP78={X -894.479919,Y -611.214172,Z 649.382202,A -163.325348,B 81.0575256,C 31.0410652,S 2,T 10,E1 0.0,E2 0.0,E3
0.0,E4 0.0,E5 0.0,E6 0.0}
DECL FDAT FP78={TOOL_NO 10,BASE_NO 14,IPO_FRAME #BASE,POINT2[] " ",TQ_STATE FALSE}
DECL LDAT LCPDAT77={VEL 2.00000,ACC 100.000,APO_DIST 100.000,APO_FAC 50.0000,AXIS_VEL 100.000,AXIS_ACC
100.000,ORI_TYP #JOINT,CIRC_TYP #BASE,JERK_FAC 50.0000,GEAR_JERK 50.0000,EXAX_IGN 0}
DECL E6POS XP79={X -864.163269,Y -640.011597,Z 514.540100,A -163.249069,B 81.0704346,C 41.2360344,S 2,T 10,E1 0.0,E2 0.0,E3
0.0,E4 0.0,E5 0.0,E6 0.0}
DECL FDAT FP79={TOOL_NO 10,BASE_NO 14,IPO_FRAME #BASE,POINT2[] " ",TQ_STATE FALSE}
DECL LDAT LCPDAT78={VEL 2.00000,ACC 100.000,APO_DIST 100.000,APO_FAC 50.0000,AXIS_VEL 100.000,AXIS_ACC
100.000,ORI_TYP #JOINT,CIRC_TYP #BASE,JERK_FAC 50.0000,GEAR_JERK 50.0000,EXAX_IGN 0}
DECL E6POS XP80={X -889.070740,Y -634.622,Z 458.484772,A 176.884583,B 74.5957184,C 23.4378777,S 2,T 10,E1 0.0,E2 0.0,E3
0.0,E4 0.0,E5 0.0,E6 0.0}
DECL FDAT FP80={TOOL_NO 10,BASE_NO 14,IPO_FRAME #BASE,POINT2[] " ",TQ_STATE FALSE}
DECL LDAT LCPDAT79={VEL 2.00000,ACC 100.000,APO_DIST 100.000,APO_FAC 50.0000,AXIS_VEL 100.000,AXIS_ACC
100.000,ORI_TYP #JOINT,CIRC_TYP #BASE,JERK_FAC 50.0000,GEAR_JERK 50.0000,EXAX_IGN 0}
DECL E6POS XP81={X -890.644531,Y -635.012268,Z 448.731567,A 176.884583,B 74.5957184,C 23.4378796,S 2,T 10,E1 0.0,E2 0.0,E3
0.0,E4 0.0,E5 0.0,E6 0.0}
DECL FDAT FP81={TOOL_NO 10,BASE_NO 14,IPO_FRAME #BASE,POINT2[] " ",TQ_STATE FALSE}
DECL LDAT LCPDAT80={VEL 2.00000,ACC 100.000,APO_DIST 100.000,APO_FAC 50.0000,AXIS_VEL 100.000,AXIS_ACC
100.000,ORI_TYP #JOINT,CIRC_TYP #BASE,JERK_FAC 50.0000,GEAR_JERK 50.0000,EXAX_IGN 0}
DECL E6POS XP82={X -896.016418,Y -632.239929,Z 450.220184,A 177.299561,B 74.8455734,C 23.8381844,S 2,T 10,E1 0.0,E2 0.0,E3
0.0,E4 0.0,E5 0.0,E6 0.0}
DECL FDAT FP82={TOOL_NO 10,BASE_NO 14,IPO_FRAME #BASE,POINT2[] " ",TQ_STATE FALSE}
DECL LDAT LCPDAT81={VEL 2.00000,ACC 100.000,APO_DIST 100.000,APO_FAC 50.0000,AXIS_VEL 100.000,AXIS_ACC
100.000,ORI_TYP #JOINT,CIRC_TYP #BASE,JERK_FAC 50.0000,GEAR_JERK 50.0000,EXAX_IGN 0}
DECL E6POS XP83={X -902.208496,Y -628.999,Z 451.881,A 177.980621,B 75.2373428,C 24.8667011,S 2,T 10,E1 0.0,E2 0.0,E3 0.0,E4
0.0,E5 0.0,E6 0.0}
DECL FDAT FP83={TOOL_NO 10,BASE_NO 14,IPO_FRAME #BASE,POINT2[] " ",TQ_STATE FALSE}
DECL LDAT LCPDAT82={VEL 2.00000,ACC 100.000,APO_DIST 100.000,APO_FAC 50.0000,AXIS_VEL 100.000,AXIS_ACC
100.000,ORI_TYP #JOINT,CIRC_TYP #BASE,JERK_FAC 50.0000,GEAR_JERK 50.0000,EXAX_IGN 0}
DECL E6POS XP84={X -915.052551,Y -622.123901,Z 455.001587,A -179.840958,B 76.3247452,C 27.7267609,S 2,T 10,E1 0.0,E2 0.0,E3
0.0,E4 0.0,E5 0.0,E6 0.0}
DECL FDAT FP84={TOOL_NO 10,BASE_NO 14,IPO_FRAME #BASE,POINT2[] " ",TQ_STATE FALSE}
DECL LDAT LCPDAT83={VEL 2.00000,ACC 100.000,APO_DIST 100.000,APO_FAC 50.0000,AXIS_VEL 100.000,AXIS_ACC
100.000,ORI_TYP #JOINT,CIRC_TYP #BASE,JERK_FAC 50.0000,GEAR_JERK 50.0000,EXAX_IGN 0}
DECL E6POS XP85={X -916.702148,Y -621.191223,Z 455.292053,A -171.876511,B 79.0393372,C 37.1016731,S 2,T 10,E1 0.0,E2 0.0,E3
0.0,E4 0.0,E5 0.0,E6 0.0}
DECL FDAT FP85={TOOL_NO 10,BASE_NO 14,IPO_FRAME #BASE,POINT2[] " ",TQ_STATE FALSE}
DECL LDAT LCPDAT84={VEL 2.00000,ACC 100.000,APO_DIST 100.000,APO_FAC 50.0000,AXIS_VEL 100.000,AXIS_ACC
100.000,ORI_TYP #JOINT,CIRC_TYP #BASE,JERK_FAC 50.0000,GEAR_JERK 50.0000,EXAX_IGN 0}
DECL E6POS XP86={X -915.992920,Y -621.557495,Z 454.881042,A -159.447784,B 81.3053207,C 50.1179237,S 2,T 10,E1 0.0,E2 0.0,E3
0.0,E4 0.0,E5 0.0,E6 0.0}
DECL FDAT FP86={TOOL_NO 10,BASE_NO 14,IPO_FRAME #BASE,POINT2[] " ",TQ_STATE FALSE}
DECL LDAT LCPDAT85={VEL 2.00000,ACC 100.000,APO_DIST 100.000,APO_FAC 50.0000,AXIS_VEL 100.000,AXIS_ACC
100.000,ORI_TYP #JOINT,CIRC_TYP #BASE,JERK_FAC 50.0000,GEAR_JERK 50.0000,EXAX_IGN 0}

```

```

DECL E6POS XP87={X -914.189697,Y -622.692139,Z 454.301758,A -125.617188,B 83.2974701,C 83.1345520,S 2,T 10,E1 0.0,E2 0.0,E3
0.0,E4 0.0,E5 0.0,E6 0.0}
DECL FDAT FP87={TOOL_NO 10,BASE_NO 14,IPO_FRAME #BASE,POINT2[] " ",TQ_STATE FALSE}
DECL LDAT LCPDAT86={VEL 2.00000,ACC 100.000,APO_DIST 100.000,APO_FAC 50.0000,AXIS_VEL 100.000,AXIS_ACC
100.000,ORI_TYP #JOINT,CIRC_TYP #BASE,JERK_FAC 50.0000,GEAR_JERK 50.0000,EXAX_IGN 0}
DECL E6POS XP88={X -904.041931,Y -628.270508,Z 454.139587,A -104.483147,B 83.1433,C 103.184074,S 2,T 10,E1 0.0,E2 0.0,E3
0.0,E4 0.0,E5 0.0,E6 0.0}
DECL FDAT FP88={TOOL_NO 10,BASE_NO 14,IPO_FRAME #BASE,POINT2[] " ",TQ_STATE FALSE}
DECL LDAT LCPDAT87={VEL 2.00000,ACC 100.000,APO_DIST 100.000,APO_FAC 50.0000,AXIS_VEL 100.000,AXIS_ACC
100.000,ORI_TYP #JOINT,CIRC_TYP #BASE,JERK_FAC 50.0000,GEAR_JERK 50.0000,EXAX_IGN 0}
DECL E6POS XP89={X -893.004395,Y -634.001343,Z 454.507904,A -93.6196442,B 82.6986084,C 112.809830,S 2,T 10,E1 0.0,E2 0.0,E3
0.0,E4 0.0,E5 0.0,E6 0.0}
DECL FDAT FP89={TOOL_NO 10,BASE_NO 14,IPO_FRAME #BASE,POINT2[] " ",TQ_STATE FALSE}
DECL LDAT LCPDAT88={VEL 2.00000,ACC 100.000,APO_DIST 100.000,APO_FAC 50.0000,AXIS_VEL 100.000,AXIS_ACC
100.000,ORI_TYP #JOINT,CIRC_TYP #BASE,JERK_FAC 50.0000,GEAR_JERK 50.0000,EXAX_IGN 0}
DECL E6POS XP90={X -869.530579,Y -645.346680,Z 457.595947,A -71.0537338,B 80.4395599,C 135.142273,S 2,T 10,E1 0.0,E2 0.0,E3
0.0,E4 0.0,E5 0.0,E6 0.0}
DECL FDAT FP90={TOOL_NO 10,BASE_NO 14,IPO_FRAME #BASE,POINT2[] " ",TQ_STATE FALSE}
DECL LDAT LCPDAT89={VEL 2.00000,ACC 100.000,APO_DIST 100.000,APO_FAC 50.0000,AXIS_VEL 100.000,AXIS_ACC
100.000,ORI_TYP #JOINT,CIRC_TYP #BASE,JERK_FAC 50.0000,GEAR_JERK 50.0000,EXAX_IGN 0}
DECL E6POS XP91={X -863.555,Y -662.770752,Z 348.195251,A -71.0750580,B 80.4431534,C 135.121292,S 2,T 10,E1 0.0,E2 0.0,E3
0.0,E4 0.0,E5 0.0,E6 0.0}
DECL FDAT FP91={TOOL_NO 10,BASE_NO 14,IPO_FRAME #BASE,POINT2[] " ",TQ_STATE FALSE}
DECL LDAT LCPDAT90={VEL 2.00000,ACC 100.000,APO_DIST 100.000,APO_FAC 50.0000,AXIS_VEL 100.000,AXIS_ACC
100.000,ORI_TYP #JOINT,CIRC_TYP #BASE,JERK_FAC 50.0000,GEAR_JERK 50.0000,EXAX_IGN 0}
DECL E6POS XP92={X -727.488342,Y -728.530701,Z 365.667542,A -71.0762787,B 80.4427109,C 135.118744,S 2,T 10,E1 0.0,E2 0.0,E3
0.0,E4 0.0,E5 0.0,E6 0.0}
DECL FDAT FP92={TOOL_NO 10,BASE_NO 14,IPO_FRAME #BASE,POINT2[] " ",TQ_STATE FALSE}
DECL LDAT LCPDAT91={VEL 2.00000,ACC 100.000,APO_DIST 100.000,APO_FAC 50.0000,AXIS_VEL 100.000,AXIS_ACC
100.000,ORI_TYP #JOINT,CIRC_TYP #BASE,JERK_FAC 50.0000,GEAR_JERK 50.0000,EXAX_IGN 0}
DECL E6POS XP93={X -842.941345,Y -393.904419,Z 305.268433,A -70.9147873,B 80.4134216,C 106.520287,S 2,T 10,E1 0.0,E2 0.0,E3
0.0,E4 0.0,E5 0.0,E6 0.0}
DECL FDAT FP93={TOOL_NO 10,BASE_NO 14,IPO_FRAME #BASE,POINT2[] " ",TQ_STATE FALSE}
DECL LDAT LCPDAT92={VEL 2.00000,ACC 100.000,APO_DIST 100.000,APO_FAC 50.0000,AXIS_VEL 100.000,AXIS_ACC
100.000,ORI_TYP #JOINT,CIRC_TYP #BASE,JERK_FAC 50.0000,GEAR_JERK 50.0000,EXAX_IGN 0}
DECL E6POS XP94={X -857.063110,Y -383.774384,Z 413.960602,A -10.1046391,B 76.0357819,C 166.545914,S 2,T 10,E1 0.0,E2 0.0,E3
0.0,E4 0.0,E5 0.0,E6 0.0}
DECL FDAT FP94={TOOL_NO 10,BASE_NO 14,IPO_FRAME #BASE,POINT2[] " ",TQ_STATE FALSE}
DECL LDAT LCPDAT93={VEL 2.00000,ACC 100.000,APO_DIST 100.000,APO_FAC 50.0000,AXIS_VEL 100.000,AXIS_ACC
100.000,ORI_TYP #JOINT,CIRC_TYP #BASE,JERK_FAC 50.0000,GEAR_JERK 50.0000,EXAX_IGN 0}
DECL E6POS XP95={X -893.729065,Y -379.038330,Z 531.930054,A -10.1047773,B 76.0358429,C 166.547058,S 2,T 10,E1 0.0,E2 0.0,E3
0.0,E4 0.0,E5 0.0,E6 0.0}
DECL FDAT FP95={TOOL_NO 10,BASE_NO 14,IPO_FRAME #BASE,POINT2[] " ",TQ_STATE FALSE}
DECL LDAT LCPDAT94={VEL 2.00000,ACC 100.000,APO_DIST 100.000,APO_FAC 50.0000,AXIS_VEL 100.000,AXIS_ACC
100.000,ORI_TYP #JOINT,CIRC_TYP #BASE,JERK_FAC 50.0000,GEAR_JERK 50.0000,EXAX_IGN 0}
DECL E6POS XP96={X -900.307861,Y -378.445740,Z 548.263184,A -10.1047783,B 76.0358429,C 166.950699,S 2,T 10,E1 0.0,E2 0.0,E3
0.0,E4 0.0,E5 0.0,E6 0.0}
DECL FDAT FP96={TOOL_NO 10,BASE_NO 14,IPO_FRAME #BASE,POINT2[] " ",TQ_STATE FALSE}
DECL LDAT LCPDAT95={VEL 2.00000,ACC 100.000,APO_DIST 100.000,APO_FAC 50.0000,AXIS_VEL 100.000,AXIS_ACC
100.000,ORI_TYP #JOINT,CIRC_TYP #BASE,JERK_FAC 50.0000,GEAR_JERK 50.0000,EXAX_IGN 0}
DECL E6POS XP97={X -907.524353,Y -378.794983,Z 546.732666,A -11.8604641,B 77.6503372,C 165.692657,S 2,T 10,E1 0.0,E2 0.0,E3
0.0,E4 0.0,E5 0.0,E6 0.0}
DECL FDAT FP97={TOOL_NO 10,BASE_NO 14,IPO_FRAME #BASE,POINT2[] " ",TQ_STATE FALSE}
DECL LDAT LCPDAT96={VEL 2.00000,ACC 100.000,APO_DIST 100.000,APO_FAC 50.0000,AXIS_VEL 100.000,AXIS_ACC
100.000,ORI_TYP #JOINT,CIRC_TYP #BASE,JERK_FAC 50.0000,GEAR_JERK 50.0000,EXAX_IGN 0}
DECL E6POS XP98={X -915.463135,Y -379.213654,Z 545.343750,A -14.6441574,B 79.6071701,C 162.662155,S 2,T 10,E1 0.0,E2 0.0,E3
0.0,E4 0.0,E5 0.0,E6 0.0}
DECL FDAT FP98={TOOL_NO 10,BASE_NO 14,IPO_FRAME #BASE,POINT2[] " ",TQ_STATE FALSE}
DECL LDAT LCPDAT97={VEL 2.00000,ACC 100.000,APO_DIST 100.000,APO_FAC 50.0000,AXIS_VEL 100.000,AXIS_ACC
100.000,ORI_TYP #JOINT,CIRC_TYP #BASE,JERK_FAC 50.0000,GEAR_JERK 50.0000,EXAX_IGN 0}
DECL E6POS XP99={X -916.010620,Y -379.238129,Z 545.275269,A -20.3170643,B 82.0725555,C 156.971909,S 2,T 10,E1 0.0,E2 0.0,E3
0.0,E4 0.0,E5 0.0,E6 0.0}
DECL FDAT FP99={TOOL_NO 10,BASE_NO 14,IPO_FRAME #BASE,POINT2[] " ",TQ_STATE FALSE}
DECL LDAT LCPDAT98={VEL 2.00000,ACC 100.000,APO_DIST 100.000,APO_FAC 50.0000,AXIS_VEL 100.000,AXIS_ACC
100.000,ORI_TYP #JOINT,CIRC_TYP #BASE,JERK_FAC 50.0000,GEAR_JERK 50.0000,EXAX_IGN 0}
DECL E6POS XP100={X -914.570740,Y -379.164886,Z 545.459778,A -26.4827518,B 83.6401367,C 150.853439,S 2,T 10,E1 0.0,E2 0.0,E3
0.0,E4 0.0,E5 0.0,E6 0.0}
DECL FDAT FP100={TOOL_NO 10,BASE_NO 14,IPO_FRAME #BASE,POINT2[] " ",TQ_STATE FALSE}
DECL LDAT LCPDAT99={VEL 2.00000,ACC 100.000,APO_DIST 100.000,APO_FAC 50.0000,AXIS_VEL 100.000,AXIS_ACC
100.000,ORI_TYP #JOINT,CIRC_TYP #BASE,JERK_FAC 50.0000,GEAR_JERK 50.0000,EXAX_IGN 0}
DECL E6POS XP101={X -910.489136,Y -378.967743,Z 545.792908,A -43.4872398,B 85.7046,C 133.918610,S 2,T 10,E1 0.0,E2 0.0,E3
0.0,E4 0.0,E5 0.0,E6 0.0}
DECL FDAT FP101={TOOL_NO 10,BASE_NO 14,IPO_FRAME #BASE,POINT2[] " ",TQ_STATE FALSE}
DECL LDAT LCPDAT100={VEL 2.00000,ACC 100.000,APO_DIST 100.000,APO_FAC 50.0000,AXIS_VEL 100.000,AXIS_ACC
100.000,ORI_TYP #JOINT,CIRC_TYP #BASE,JERK_FAC 50.0000,GEAR_JERK 50.0000,EXAX_IGN 0}

```

DECL E6POS XP102={X -905.139038,Y -380.274445,Z 517.248413,A -138.930313,B 85.0459824,C 38.6612244,S 2,T 10,E1 0.0,E2 0.0,E3 0.0,E4 0.0,E5 0.0,E6 0.0}
DECL FDAT FP102={TOOL_NO 10,BASE_NO 14,IPO_FRAME #BASE,POINT2[] " ",TQ_STATE FALSE}
DECL LDAT LCPDAT101={VEL 2.00000,ACC 100.000,APO_DIST 100.000,APO_FAC 50.0000,AXIS_VEL 100.000,AXIS_ACC 100.000,ORI_TYP #JOINT,CIRC_TYP #BASE,JERK_FAC 50.0000,GEAR_JERK 50.0000,EXAX_IGN 0}
DECL E6POS XP103={X -901.649048,Y -380.133942,Z 517.012390,A -145.805496,B 84.1351471,C 32.2512932,S 2,T 10,E1 0.0,E2 0.0,E3 0.0,E4 0.0,E5 0.0,E6 0.0}
DECL FDAT FP103={TOOL_NO 10,BASE_NO 14,IPO_FRAME #BASE,POINT2[] " ",TQ_STATE FALSE}
DECL LDAT LCPDAT102={VEL 2.00000,ACC 100.000,APO_DIST 100.000,APO_FAC 50.0000,AXIS_VEL 100.000,AXIS_ACC 100.000,ORI_TYP #JOINT,CIRC_TYP #BASE,JERK_FAC 50.0000,GEAR_JERK 50.0000,EXAX_IGN 0}
DECL E6POS XP104={X -889.715942,Y -379.771545,Z 515.931,A -149.714050,B 83.4095078,C 28.6564236,S 2,T 10,E1 0.0,E2 0.0,E3 0.0,E4 0.0,E5 0.0,E6 0.0}
DECL FDAT FP104={TOOL_NO 10,BASE_NO 14,IPO_FRAME #BASE,POINT2[] " ",TQ_STATE FALSE}
DECL LDAT LCPDAT103={VEL 2.00000,ACC 100.000,APO_DIST 100.000,APO_FAC 50.0000,AXIS_VEL 100.000,AXIS_ACC 100.000,ORI_TYP #JOINT,CIRC_TYP #BASE,JERK_FAC 50.0000,GEAR_JERK 50.0000,EXAX_IGN 0}
DECL E6POS XP105={X -876.855408,Y -379.441620,Z 514.628784,A -151.448837,B 83.0206680,C 26.9337692,S 2,T 10,E1 0.0,E2 0.0,E3 0.0,E4 0.0,E5 0.0,E6 0.0}
DECL FDAT FP105={TOOL_NO 10,BASE_NO 14,IPO_FRAME #BASE,POINT2[] " ",TQ_STATE FALSE}
DECL LDAT LCPDAT104={VEL 2.00000,ACC 100.000,APO_DIST 100.000,APO_FAC 50.0000,AXIS_VEL 100.000,AXIS_ACC 100.000,ORI_TYP #JOINT,CIRC_TYP #BASE,JERK_FAC 50.0000,GEAR_JERK 50.0000,EXAX_IGN 0}
DECL E6POS XP106={X -864.808960,Y -379.137665,Z 513.315674,A -153.714523,B 82.4272614,C 24.6862869,S 2,T 10,E1 0.0,E2 0.0,E3 0.0,E4 0.0,E5 0.0,E6 0.0}
DECL FDAT FP106={TOOL_NO 10,BASE_NO 14,IPO_FRAME #BASE,POINT2[] " ",TQ_STATE FALSE}
DECL LDAT LCPDAT105={VEL 2.00000,ACC 100.000,APO_DIST 100.000,APO_FAC 50.0000,AXIS_VEL 100.000,AXIS_ACC 100.000,ORI_TYP #JOINT,CIRC_TYP #BASE,JERK_FAC 50.0000,GEAR_JERK 50.0000,EXAX_IGN 0}
DECL E6POS XP107={X -855.614746,Y -378.933777,Z 511.793945,A -159.843643,B 80.0775452,C 18.6271820,S 2,T 10,E1 0.0,E2 0.0,E3 0.0,E4 0.0,E5 0.0,E6 0.0}
DECL FDAT FP107={TOOL_NO 10,BASE_NO 14,IPO_FRAME #BASE,POINT2[] " ",TQ_STATE FALSE}
DECL LDAT LCPDAT106={VEL 2.00000,ACC 100.000,APO_DIST 100.000,APO_FAC 50.0000,AXIS_VEL 100.000,AXIS_ACC 100.000,ORI_TYP #JOINT,CIRC_TYP #BASE,JERK_FAC 50.0000,GEAR_JERK 50.0000,EXAX_IGN 0}
DECL E6POS XP108={X -826.207092,Y -368.158569,Z 690.766174,A -159.846893,B 80.0775146,C 18.6258564,S 2,T 10,E1 0.0,E2 0.0,E3 0.0,E4 0.0,E5 0.0,E6 0.0}
DECL FDAT FP108={TOOL_NO 10,BASE_NO 14,IPO_FRAME #BASE,POINT2[] " ",TQ_STATE FALSE}
DECL LDAT LCPDAT107={VEL 2.00000,ACC 100.000,APO_DIST 100.000,APO_FAC 50.0000,AXIS_VEL 100.000,AXIS_ACC 100.000,ORI_TYP #JOINT,CIRC_TYP #BASE,JERK_FAC 50.0000,GEAR_JERK 50.0000,EXAX_IGN 0}
DECL E6POS XP109={X -723.609192,Y -717.368958,Z 486.168671,A -159.827774,B 80.0860,C 18.6484184,S 2,T 10,E1 0.0,E2 0.0,E3 0.0,E4 0.0,E5 0.0,E6 0.0}
DECL FDAT FP109={TOOL_NO 10,BASE_NO 14,IPO_FRAME #BASE,POINT2[] " ",TQ_STATE FALSE}
DECL LDAT LCPDAT108={VEL 2.00000,ACC 100.000,APO_DIST 100.000,APO_FAC 50.0000,AXIS_VEL 100.000,AXIS_ACC 100.000,ORI_TYP #JOINT,CIRC_TYP #BASE,JERK_FAC 50.0000,GEAR_JERK 50.0000,EXAX_IGN 0}
DECL E6POS XP110={X -747.384766,Y -726.121155,Z 340.262848,A -160.087494,B 80.0842133,C 18.4199047,S 2,T 10,E1 0.0,E2 0.0,E3 0.0,E4 0.0,E5 0.0,E6 0.0}
DECL FDAT FP110={TOOL_NO 10,BASE_NO 14,IPO_FRAME #BASE,POINT2[] " ",TQ_STATE FALSE}
DECL LDAT LCPDAT109={VEL 2.00000,ACC 100.000,APO_DIST 100.000,APO_FAC 50.0000,AXIS_VEL 100.000,AXIS_ACC 100.000,ORI_TYP #JOINT,CIRC_TYP #BASE,JERK_FAC 50.0000,GEAR_JERK 50.0000,EXAX_IGN 0}
DECL E6POS XP111={X -897.466125,Y -305.158295,Z 413.447418,A -24.7111206,B 87.4997,C 141.724976,S 2,T 10,E1 0.0,E2 0.0,E3 0.0,E4 0.0,E5 0.0,E6 0.0}
DECL FDAT FP111={TOOL_NO 10,BASE_NO 14,IPO_FRAME #BASE,POINT2[] " ",TQ_STATE FALSE}
DECL LDAT LCPDAT110={VEL 2.00000,ACC 100.000,APO_DIST 100.000,APO_FAC 50.0000,AXIS_VEL 100.000,AXIS_ACC 100.000,ORI_TYP #JOINT,CIRC_TYP #BASE,JERK_FAC 50.0000,GEAR_JERK 50.0000,EXAX_IGN 0}
DECL E6POS XP112={X -921.903076,Y -304.332703,Z 456.573303,A -24.7111244,B 87.4997,C 141.724976,S 2,T 10,E1 0.0,E2 0.0,E3 0.0,E4 0.0,E5 0.0,E6 0.0}
DECL FDAT FP112={TOOL_NO 10,BASE_NO 14,IPO_FRAME #BASE,POINT2[] " ",TQ_STATE FALSE}
DECL LDAT LCPDAT111={VEL 2.00000,ACC 100.000,APO_DIST 100.000,APO_FAC 50.0000,AXIS_VEL 100.000,AXIS_ACC 100.000,ORI_TYP #JOINT,CIRC_TYP #BASE,JERK_FAC 50.0000,GEAR_JERK 50.0000,EXAX_IGN 0}
DECL E6POS XP113={X -926.570740,Y -304.121246,Z 464.701019,A -24.7111282,B 87.4997,C 141.724976,S 2,T 10,E1 0.0,E2 0.0,E3 0.0,E4 0.0,E5 0.0,E6 0.0}
DECL FDAT FP113={TOOL_NO 10,BASE_NO 14,IPO_FRAME #BASE,POINT2[] " ",TQ_STATE FALSE}
DECL LDAT LCPDAT112={VEL 2.00000,ACC 100.000,APO_DIST 100.000,APO_FAC 50.0000,AXIS_VEL 100.000,AXIS_ACC 100.000,ORI_TYP #JOINT,CIRC_TYP #BASE,JERK_FAC 50.0000,GEAR_JERK 50.0000,EXAX_IGN 0}
DECL E6POS XP114={X -933.412903,Y -305.772980,Z 464.723083,A -83.0516052,B 88.4412308,C 83.2269592,S 2,T 10,E1 0.0,E2 0.0,E3 0.0,E4 0.0,E5 0.0,E6 0.0}
DECL FDAT FP114={TOOL_NO 10,BASE_NO 14,IPO_FRAME #BASE,POINT2[] " ",TQ_STATE FALSE}
DECL LDAT LCPDAT113={VEL 2.00000,ACC 100.000,APO_DIST 100.000,APO_FAC 50.0000,AXIS_VEL 100.000,AXIS_ACC 100.000,ORI_TYP #JOINT,CIRC_TYP #BASE,JERK_FAC 50.0000,GEAR_JERK 50.0000,EXAX_IGN 0}
DECL E6POS XP115={X -937.923950,Y -306.852844,Z 464.973877,A -139.757858,B 86.5366,C 26.7352562,S 2,T 10,E1 0.0,E2 0.0,E3 0.0,E4 0.0,E5 0.0,E6 0.0}
DECL FDAT FP115={TOOL_NO 10,BASE_NO 14,IPO_FRAME #BASE,POINT2[] " ",TQ_STATE FALSE}
DECL LDAT LCPDAT114={VEL 2.00000,ACC 100.000,APO_DIST 100.000,APO_FAC 50.0000,AXIS_VEL 100.000,AXIS_ACC 100.000,ORI_TYP #JOINT,CIRC_TYP #BASE,JERK_FAC 50.0000,GEAR_JERK 50.0000,EXAX_IGN 0}
DECL E6POS XP116={X -939.847290,Y -307.303314,Z 465.246,A -155.288589,B 82.0062561,C 11.4092712,S 2,T 10,E1 0.0,E2 0.0,E3 0.0,E4 0.0,E5 0.0,E6 0.0}
DECL FDAT FP116={TOOL_NO 10,BASE_NO 14,IPO_FRAME #BASE,POINT2[] " ",TQ_STATE FALSE}
DECL LDAT LCPDAT115={VEL 2.00000,ACC 100.000,APO_DIST 100.000,APO_FAC 50.0000,AXIS_VEL 100.000,AXIS_ACC 100.000,ORI_TYP #JOINT,CIRC_TYP #BASE,JERK_FAC 50.0000,GEAR_JERK 50.0000,EXAX_IGN 0}

```

DECL E6POS XP117={X -939.847290,Y -307.303345,Z 465.246,A -158.458557,B 78.9898148,C 8.40438461,S 2,T 10,E1 0.0,E2 0.0,E3
0.0,E4 0.0,E5 0.0,E6 0.0}
DECL FDAT FP117={TOOL_NO 10,BASE_NO 14,IPO_FRAME #BASE,POINT2[] " ",TQ_STATE FALSE}
DECL LDAT LCPDAT116={VEL 2.00000,ACC 100.000,APO_DIST 100.000,APO_FAC 50.0000,AXIS_VEL 100.000,AXIS_ACC
100.000,ORI_TYP #JOINT,CIRC_TYP #BASE,JERK_FAC 50.0000,GEAR_JERK 50.0000,EXAX_IGN 0}
DECL E6POS XP118={X -935.348450,Y -306.266296,Z 464.357666,A -159.441437,B 77.5626755,C 7.66872072,S 2,T 10,E1 0.0,E2 0.0,E3
0.0,E4 0.0,E5 0.0,E6 0.0}
DECL FDAT FP118={TOOL_NO 10,BASE_NO 14,IPO_FRAME #BASE,POINT2[] " ",TQ_STATE FALSE}
DECL LDAT LCPDAT117={VEL 2.00000,ACC 100.000,APO_DIST 100.000,APO_FAC 50.0000,AXIS_VEL 100.000,AXIS_ACC
100.000,ORI_TYP #JOINT,CIRC_TYP #BASE,JERK_FAC 50.0000,GEAR_JERK 50.0000,EXAX_IGN 0}
DECL E6POS XP119={X -925.202698,Y -303.978424,Z 462.085327,A -159.951904,B 76.6931534,C 7.37553596,S 2,T 10,E1 0.0,E2 0.0,E3
0.0,E4 0.0,E5 0.0,E6 0.0}
DECL FDAT FP119={TOOL_NO 10,BASE_NO 14,IPO_FRAME #BASE,POINT2[] " ",TQ_STATE FALSE}
DECL LDAT LCPDAT118={VEL 2.00000,ACC 100.000,APO_DIST 100.000,APO_FAC 50.0000,AXIS_VEL 100.000,AXIS_ACC
100.000,ORI_TYP #JOINT,CIRC_TYP #BASE,JERK_FAC 50.0000,GEAR_JERK 50.0000,EXAX_IGN 0}
DECL E6POS XP120={X -914.465,Y -301.603607,Z 459.507019,A -160.162567,B 76.3090363,C 7.61420488,S 2,T 10,E1 0.0,E2 0.0,E3
0.0,E4 0.0,E5 0.0,E6 0.0}
DECL FDAT FP120={TOOL_NO 10,BASE_NO 14,IPO_FRAME #BASE,POINT2[] " ",TQ_STATE FALSE}
DECL LDAT LCPDAT119={VEL 2.00000,ACC 100.000,APO_DIST 100.000,APO_FAC 50.0000,AXIS_VEL 100.000,AXIS_ACC
100.000,ORI_TYP #JOINT,CIRC_TYP #BASE,JERK_FAC 50.0000,GEAR_JERK 50.0000,EXAX_IGN 0}
DECL E6POS XP121={X -904.794373,Y -299.547485,Z 457.120972,A -160.497589,B 75.6892929,C 7.28912687,S 2,T 10,E1 0.0,E2 0.0,E3
0.0,E4 0.0,E5 0.0,E6 0.0}
DECL FDAT FP121={TOOL_NO 10,BASE_NO 14,IPO_FRAME #BASE,POINT2[] " ",TQ_STATE FALSE}
DECL LDAT LCPDAT120={VEL 2.00000,ACC 100.000,APO_DIST 100.000,APO_FAC 50.0000,AXIS_VEL 100.000,AXIS_ACC
100.000,ORI_TYP #JOINT,CIRC_TYP #BASE,JERK_FAC 50.0000,GEAR_JERK 50.0000,EXAX_IGN 0}
DECL E6POS XP122={X -868.758301,Y -286.799652,Z 606.877441,A -160.360611,B 75.6988754,C 7.42586040,S 2,T 10,E1 0.0,E2 0.0,E3
0.0,E4 0.0,E5 0.0,E6 0.0}
DECL FDAT FP122={TOOL_NO 10,BASE_NO 14,IPO_FRAME #BASE,POINT2[] " ",TQ_STATE FALSE}
DECL LDAT LCPDAT121={VEL 2.00000,ACC 100.000,APO_DIST 100.000,APO_FAC 50.0000,AXIS_VEL 100.000,AXIS_ACC
100.000,ORI_TYP #JOINT,CIRC_TYP #BASE,JERK_FAC 50.0000,GEAR_JERK 50.0000,EXAX_IGN 0}
DECL E6POS XP123={X -868.743469,Y -286.770203,Z 606.756042,A -160.271759,B 75.7002869,C 43.8599663,S 2,T 10,E1 0.0,E2 0.0,E3
0.0,E4 0.0,E5 0.0,E6 0.0}
DECL FDAT FP123={TOOL_NO 10,BASE_NO 14,IPO_FRAME #BASE,POINT2[] " ",TQ_STATE FALSE}
DECL LDAT LCPDAT122={VEL 2.00000,ACC 100.000,APO_DIST 100.000,APO_FAC 50.0000,AXIS_VEL 100.000,AXIS_ACC
100.000,ORI_TYP #JOINT,CIRC_TYP #BASE,JERK_FAC 50.0000,GEAR_JERK 50.0000,EXAX_IGN 0}
ENDDAT

```

Código para la programación de la Trayectoria B

Extensión .src

```

&ACCESS RVP
&REL 357
&PARAM EDITMASK = *
&PARAM TEMPLATE = C:\KRC\Roboter\Template\vorgabe
&PARAM DISKPATH = KRC:\R1\TESISWEBO
DEF pelton2()
:FOLD INI;% {PE}
;FOLD BASISTECH INI
  GLOBAL INTERRUPT DECL 3 WHEN $STOPMESS==TRUE DO IR_STOPM ( )
  INTERRUPT ON 3
  BAS (#INITMOV,0 )
;ENDFOLD (BASISTECH INI)
:FOLD USER INI
;Make your modifications here

;ENDFOLD (USER INI)
;ENDFOLD (INI)

:FOLD PTP P1 Vel=100 % PDAT1 Tool[10]:b1 Base[14]:b1;% {PE}%R 8.3.44,%MKUKATPBASIS,%CMOVE,%VPTP,%P 1:PTP, 2:P1,
3:, 5:100, 7:PDAT1
$BWDSTART=FALSE
PDAT_ACT=PPDAT1
FDAT_ACT=FP1
BAS(#PTP_PARAMS,100)
PTP XP1
;ENDFOLD
LOOP
:FOLD LIN P42 CONT Vel=1 m/s CPDAT41 Tool[10]:b1 Base[14]:b1;% {PE}%R 8.3.44,%MKUKATPBASIS,%CMOVE,%VLIN,%P
1:LIN, 2:P42, 3:C_DIS C_DIS, 5:1, 7:CPDAT41
$BWDSTART=FALSE
LDAT_ACT=LCPDAT41
FDAT_ACT=FP42
BAS(#CP_PARAMS,1)
LIN XP42 C_DIS C_DIS
;ENDFOLD
:FOLD LIN P43 CONT Vel=1 m/s CPDAT42 Tool[10]:b1 Base[14]:b1;% {PE}%R 8.3.44,%MKUKATPBASIS,%CMOVE,%VLIN,%P
1:LIN, 2:P43, 3:C_DIS C_DIS, 5:1, 7:CPDAT42
$BWDSTART=FALSE
LDAT_ACT=LCPDAT42
FDAT_ACT=FP43
BAS(#CP_PARAMS,1)
LIN XP43 C_DIS C_DIS
;ENDFOLD
:FOLD LIN P44 CONT Vel=1 m/s CPDAT43 Tool[10]:b1 Base[14]:b1;% {PE}%R 8.3.44,%MKUKATPBASIS,%CMOVE,%VLIN,%P
1:LIN, 2:P44, 3:C_DIS C_DIS, 5:1, 7:CPDAT43
$BWDSTART=FALSE
LDAT_ACT=LCPDAT43
FDAT_ACT=FP44
BAS(#CP_PARAMS,1)
LIN XP44 C_DIS C_DIS
;ENDFOLD
:FOLD LIN P45 CONT Vel=1 m/s CPDAT44 Tool[10]:b1 Base[14]:b1;% {PE}%R 8.3.44,%MKUKATPBASIS,%CMOVE,%VLIN,%P
1:LIN, 2:P45, 3:C_DIS C_DIS, 5:1, 7:CPDAT44
$BWDSTART=FALSE
LDAT_ACT=LCPDAT44
FDAT_ACT=FP45
BAS(#CP_PARAMS,1)
LIN XP45 C_DIS C_DIS
;ENDFOLD
:FOLD LIN P46 CONT Vel=1 m/s CPDAT45 Tool[10]:b1 Base[14]:b1;% {PE}%R 8.3.44,%MKUKATPBASIS,%CMOVE,%VLIN,%P
1:LIN, 2:P46, 3:C_DIS C_DIS, 5:1, 7:CPDAT45
$BWDSTART=FALSE
LDAT_ACT=LCPDAT45
FDAT_ACT=FP46
BAS(#CP_PARAMS,1)
LIN XP46 C_DIS C_DIS
;ENDFOLD

```

```
;FOLD LIN P47 CONT Vel=1 m/s CPDAT46 Tool[10]:b1 Base[14]:b1;% {PE}%R 8.3.44,%MKUKATPBASIS,%CMOVE,%VLIN,%P
1:LIN, 2:P47, 3:C_DIS C_DIS, 5:1, 7:CPDAT46
$BWDSTART=FALSE
LDAT_ACT=LCPDAT46
FDAT_ACT=FP47
BAS(#CP_PARAMS,1)
LIN XP47 C_DIS C_DIS
;ENDFOLD
;FOLD LIN P48 CONT Vel=1 m/s CPDAT47 Tool[10]:b1 Base[14]:b1;% {PE}%R 8.3.44,%MKUKATPBASIS,%CMOVE,%VLIN,%P
1:LIN, 2:P48, 3:C_DIS C_DIS, 5:1, 7:CPDAT47
$BWDSTART=FALSE
LDAT_ACT=LCPDAT47
FDAT_ACT=FP48
BAS(#CP_PARAMS,1)
LIN XP48 C_DIS C_DIS
;ENDFOLD
;FOLD LIN P49 CONT Vel=1 m/s CPDAT48 Tool[10]:b1 Base[14]:b1;% {PE}%R 8.3.44,%MKUKATPBASIS,%CMOVE,%VLIN,%P
1:LIN, 2:P49, 3:C_DIS C_DIS, 5:1, 7:CPDAT48
$BWDSTART=FALSE
LDAT_ACT=LCPDAT48
FDAT_ACT=FP49
BAS(#CP_PARAMS,1)
LIN XP49 C_DIS C_DIS
;ENDFOLD
;FOLD LIN P50 CONT Vel=1 m/s CPDAT49 Tool[10]:b1 Base[14]:b1;% {PE}%R 8.3.44,%MKUKATPBASIS,%CMOVE,%VLIN,%P
1:LIN, 2:P50, 3:C_DIS C_DIS, 5:1, 7:CPDAT49
$BWDSTART=FALSE
LDAT_ACT=LCPDAT49
FDAT_ACT=FP50
BAS(#CP_PARAMS,1)
LIN XP50 C_DIS C_DIS
;ENDFOLD
;FOLD LIN P51 CONT Vel=1 m/s CPDAT50 Tool[10]:b1 Base[14]:b1;% {PE}%R 8.3.44,%MKUKATPBASIS,%CMOVE,%VLIN,%P
1:LIN, 2:P51, 3:C_DIS C_DIS, 5:1, 7:CPDAT50
$BWDSTART=FALSE
LDAT_ACT=LCPDAT50
FDAT_ACT=FP51
BAS(#CP_PARAMS,1)
LIN XP51 C_DIS C_DIS
;ENDFOLD
;FOLD LIN P52 CONT Vel=1 m/s CPDAT51 Tool[10]:b1 Base[14]:b1;% {PE}%R 8.3.44,%MKUKATPBASIS,%CMOVE,%VLIN,%P
1:LIN, 2:P52, 3:C_DIS C_DIS, 5:1, 7:CPDAT51
$BWDSTART=FALSE
LDAT_ACT=LCPDAT51
FDAT_ACT=FP52
BAS(#CP_PARAMS,1)
LIN XP52 C_DIS C_DIS
;ENDFOLD
;FOLD LIN P53 CONT Vel=1 m/s CPDAT52 Tool[10]:b1 Base[14]:b1;% {PE}%R 8.3.44,%MKUKATPBASIS,%CMOVE,%VLIN,%P
1:LIN, 2:P53, 3:C_DIS C_DIS, 5:1, 7:CPDAT52
$BWDSTART=FALSE
LDAT_ACT=LCPDAT52
FDAT_ACT=FP53
BAS(#CP_PARAMS,1)
LIN XP53 C_DIS C_DIS
;ENDFOLD
;FOLD LIN P54 CONT Vel=1 m/s CPDAT53 Tool[10]:b1 Base[14]:b1;% {PE}%R 8.3.44,%MKUKATPBASIS,%CMOVE,%VLIN,%P
1:LIN, 2:P54, 3:C_DIS C_DIS, 5:1, 7:CPDAT53
$BWDSTART=FALSE
LDAT_ACT=LCPDAT53
FDAT_ACT=FP54
BAS(#CP_PARAMS,1)
LIN XP54 C_DIS C_DIS
;ENDFOLD
;FOLD LIN P55 CONT Vel=1 m/s CPDAT54 Tool[10]:b1 Base[14]:b1;% {PE}%R 8.3.44,%MKUKATPBASIS,%CMOVE,%VLIN,%P
1:LIN, 2:P55, 3:C_DIS C_DIS, 5:1, 7:CPDAT54
$BWDSTART=FALSE
LDAT_ACT=LCPDAT54
FDAT_ACT=FP55
BAS(#CP_PARAMS,1)
LIN XP55 C_DIS C_DIS
;ENDFOLD
;FOLD LIN P56 CONT Vel=1 m/s CPDAT55 Tool[10]:b1 Base[14]:b1;% {PE}%R 8.3.44,%MKUKATPBASIS,%CMOVE,%VLIN,%P
1:LIN, 2:P56, 3:C_DIS C_DIS, 5:1, 7:CPDAT55
$BWDSTART=FALSE
```

```

LDAT_ACT=LCPDAT55
FDAT_ACT=FP56
BAS(#CP_PARAMS,1)
LIN XP56 C_DIS C_DIS
:ENDFOLD
:FOLD LIN P57 CONT Vel=1 m/s CPDAT56 Tool[10]:b1 Base[14]:b1;% {PE}%R 8.3.44,%MKUKATPBASIS,%CMOVE,%VLIN,%P
1:LIN, 2:P57, 3:C_DIS C_DIS, 5:1, 7:CPDAT56
$BWDSTART=FALSE
LDAT_ACT=LCPDAT56
FDAT_ACT=FP57
BAS(#CP_PARAMS,1)
LIN XP57 C_DIS C_DIS
:ENDFOLD
:FOLD LIN P58 CONT Vel=1 m/s CPDAT57 Tool[10]:b1 Base[14]:b1;% {PE}%R 8.3.44,%MKUKATPBASIS,%CMOVE,%VLIN,%P
1:LIN, 2:P58, 3:C_DIS C_DIS, 5:1, 7:CPDAT57
$BWDSTART=FALSE
LDAT_ACT=LCPDAT57
FDAT_ACT=FP58
BAS(#CP_PARAMS,1)
LIN XP58 C_DIS C_DIS
:ENDFOLD
:FOLD LIN P59 CONT Vel=1 m/s CPDAT58 Tool[10]:b1 Base[14]:b1;% {PE}%R 8.3.44,%MKUKATPBASIS,%CMOVE,%VLIN,%P
1:LIN, 2:P59, 3:C_DIS C_DIS, 5:1, 7:CPDAT58
$BWDSTART=FALSE
LDAT_ACT=LCPDAT58
FDAT_ACT=FP59
BAS(#CP_PARAMS,1)
LIN XP59 C_DIS C_DIS
:ENDFOLD
:FOLD LIN P60 CONT Vel=1 m/s CPDAT59 Tool[10]:b1 Base[14]:b1;% {PE}%R 8.3.44,%MKUKATPBASIS,%CMOVE,%VLIN,%P
1:LIN, 2:P60, 3:C_DIS C_DIS, 5:1, 7:CPDAT59
$BWDSTART=FALSE
LDAT_ACT=LCPDAT59
FDAT_ACT=FP60
BAS(#CP_PARAMS,1)
LIN XP60 C_DIS C_DIS
:ENDFOLD
:FOLD LIN P61 CONT Vel=1 m/s CPDAT60 Tool[10]:b1 Base[14]:b1;% {PE}%R 8.3.44,%MKUKATPBASIS,%CMOVE,%VLIN,%P
1:LIN, 2:P61, 3:C_DIS C_DIS, 5:1, 7:CPDAT60
$BWDSTART=FALSE
LDAT_ACT=LCPDAT60
FDAT_ACT=FP61
BAS(#CP_PARAMS,1)
LIN XP61 C_DIS C_DIS
:ENDFOLD
:FOLD LIN P62 CONT Vel=1 m/s CPDAT61 Tool[10]:b1 Base[14]:b1;% {PE}%R 8.3.44,%MKUKATPBASIS,%CMOVE,%VLIN,%P
1:LIN, 2:P62, 3:C_DIS C_DIS, 5:1, 7:CPDAT61
$BWDSTART=FALSE
LDAT_ACT=LCPDAT61
FDAT_ACT=FP62
BAS(#CP_PARAMS,1)
LIN XP62 C_DIS C_DIS
:ENDFOLD
:FOLD LIN P63 CONT Vel=1 m/s CPDAT62 Tool[10]:b1 Base[14]:b1;% {PE}%R 8.3.44,%MKUKATPBASIS,%CMOVE,%VLIN,%P
1:LIN, 2:P63, 3:C_DIS C_DIS, 5:1, 7:CPDAT62
$BWDSTART=FALSE
LDAT_ACT=LCPDAT62
FDAT_ACT=FP63
BAS(#CP_PARAMS,1)
LIN XP63 C_DIS C_DIS
:ENDFOLD
:FOLD LIN P64 CONT Vel=1 m/s CPDAT63 Tool[10]:b1 Base[14]:b1;% {PE}%R 8.3.44,%MKUKATPBASIS,%CMOVE,%VLIN,%P
1:LIN, 2:P64, 3:C_DIS C_DIS, 5:1, 7:CPDAT63
$BWDSTART=FALSE
LDAT_ACT=LCPDAT63
FDAT_ACT=FP64
BAS(#CP_PARAMS,1)
LIN XP64 C_DIS C_DIS
:ENDFOLD
:FOLD LIN P65 CONT Vel=1 m/s CPDAT64 Tool[10]:b1 Base[14]:b1;% {PE}%R 8.3.44,%MKUKATPBASIS,%CMOVE,%VLIN,%P
1:LIN, 2:P65, 3:C_DIS C_DIS, 5:1, 7:CPDAT64
$BWDSTART=FALSE
LDAT_ACT=LCPDAT64
FDAT_ACT=FP65
BAS(#CP_PARAMS,1)

```

```

LIN XP65 C_DIS C_DIS
:ENDFOLD
:FOLD LIN P66 CONT Vel=1 m/s CPDAT65 Tool[10]:b1 Base[14]:b1;%{PE}%R 8.3.44,%MKUKATPBASIS,%CMOVE,%VLIN,%P
1:LIN, 2:P66, 3:C_DIS C_DIS, 5:1, 7:CPDAT65
$BWDSTART=FALSE
LDAT_ACT=LCPDAT65
FDAT_ACT=FP66
BAS(#CP_PARAMS,1)
LIN XP66 C_DIS C_DIS
:ENDFOLD
:FOLD LIN P67 CONT Vel=1 m/s CPDAT66 Tool[10]:b1 Base[14]:b1;%{PE}%R 8.3.44,%MKUKATPBASIS,%CMOVE,%VLIN,%P
1:LIN, 2:P67, 3:C_DIS C_DIS, 5:1, 7:CPDAT66
$BWDSTART=FALSE
LDAT_ACT=LCPDAT66
FDAT_ACT=FP67
BAS(#CP_PARAMS,1)
LIN XP67 C_DIS C_DIS
:ENDFOLD
:FOLD LIN P68 CONT Vel=1 m/s CPDAT67 Tool[10]:b1 Base[14]:b1;%{PE}%R 8.3.44,%MKUKATPBASIS,%CMOVE,%VLIN,%P
1:LIN, 2:P68, 3:C_DIS C_DIS, 5:1, 7:CPDAT67
$BWDSTART=FALSE
LDAT_ACT=LCPDAT67
FDAT_ACT=FP68
BAS(#CP_PARAMS,1)
LIN XP68 C_DIS C_DIS
:ENDFOLD
:FOLD LIN P69 CONT Vel=1 m/s CPDAT68 Tool[10]:b1 Base[14]:b1;%{PE}%R 8.3.44,%MKUKATPBASIS,%CMOVE,%VLIN,%P
1:LIN, 2:P69, 3:C_DIS C_DIS, 5:1, 7:CPDAT68
$BWDSTART=FALSE
LDAT_ACT=LCPDAT68
FDAT_ACT=FP69
BAS(#CP_PARAMS,1)
LIN XP69 C_DIS C_DIS
:ENDFOLD
:FOLD LIN P70 CONT Vel=1 m/s CPDAT69 Tool[10]:b1 Base[14]:b1;%{PE}%R 8.3.44,%MKUKATPBASIS,%CMOVE,%VLIN,%P
1:LIN, 2:P70, 3:C_DIS C_DIS, 5:1, 7:CPDAT69
$BWDSTART=FALSE
LDAT_ACT=LCPDAT69
FDAT_ACT=FP70
BAS(#CP_PARAMS,1)
LIN XP70 C_DIS C_DIS
:ENDFOLD
:FOLD LIN P71 CONT Vel=1 m/s CPDAT70 Tool[10]:b1 Base[14]:b1;%{PE}%R 8.3.44,%MKUKATPBASIS,%CMOVE,%VLIN,%P
1:LIN, 2:P71, 3:C_DIS C_DIS, 5:1, 7:CPDAT70
$BWDSTART=FALSE
LDAT_ACT=LCPDAT70
FDAT_ACT=FP71
BAS(#CP_PARAMS,1)
LIN XP71 C_DIS C_DIS
:ENDFOLD
:FOLD LIN P72 CONT Vel=1 m/s CPDAT71 Tool[10]:b1 Base[14]:b1;%{PE}%R 8.3.44,%MKUKATPBASIS,%CMOVE,%VLIN,%P
1:LIN, 2:P72, 3:C_DIS C_DIS, 5:1, 7:CPDAT71
$BWDSTART=FALSE
LDAT_ACT=LCPDAT71
FDAT_ACT=FP72
BAS(#CP_PARAMS,1)
LIN XP72 C_DIS C_DIS
:ENDFOLD
:FOLD LIN P73 CONT Vel=1 m/s CPDAT72 Tool[10]:b1 Base[14]:b1;%{PE}%R 8.3.44,%MKUKATPBASIS,%CMOVE,%VLIN,%P
1:LIN, 2:P73, 3:C_DIS C_DIS, 5:1, 7:CPDAT72
$BWDSTART=FALSE
LDAT_ACT=LCPDAT72
FDAT_ACT=FP73
BAS(#CP_PARAMS,1)
LIN XP73 C_DIS C_DIS
:ENDFOLD
:FOLD LIN P74 CONT Vel=1 m/s CPDAT73 Tool[10]:b1 Base[14]:b1;%{PE}%R 8.3.44,%MKUKATPBASIS,%CMOVE,%VLIN,%P
1:LIN, 2:P74, 3:C_DIS C_DIS, 5:1, 7:CPDAT73
$BWDSTART=FALSE
LDAT_ACT=LCPDAT73
FDAT_ACT=FP74
BAS(#CP_PARAMS,1)
LIN XP74 C_DIS C_DIS
:ENDFOLD

```



```

:FOLD LIN P75 CONT Vel=1 m/s CPDAT74 Tool[10]:b1 Base[14]:b1;% {PE}%R 8.3.44,%MKUKATPBASIS,%CMOVE,%VLIN,%P
1:LIN, 2:P75, 3:C_DIS C_DIS, 5:1, 7:CPDAT74
$BWDSTART=FALSE
LDAT_ACT=LCPDAT74
FDAT_ACT=FP75
BAS(#CP_PARAMS,1)
LIN XP75 C_DIS C_DIS
:ENDFOLD
:FOLD LIN P76 CONT Vel=1 m/s CPDAT75 Tool[10]:b1 Base[14]:b1;% {PE}%R 8.3.44,%MKUKATPBASIS,%CMOVE,%VLIN,%P
1:LIN, 2:P76, 3:C_DIS C_DIS, 5:1, 7:CPDAT75
$BWDSTART=FALSE
LDAT_ACT=LCPDAT75
FDAT_ACT=FP76
BAS(#CP_PARAMS,1)
LIN XP76 C_DIS C_DIS
:ENDFOLD
:FOLD LIN P77 CONT Vel=1 m/s CPDAT76 Tool[10]:b1 Base[14]:b1;% {PE}%R 8.3.44,%MKUKATPBASIS,%CMOVE,%VLIN,%P
1:LIN, 2:P77, 3:C_DIS C_DIS, 5:1, 7:CPDAT76
$BWDSTART=FALSE
LDAT_ACT=LCPDAT76
FDAT_ACT=FP77
BAS(#CP_PARAMS,1)
LIN XP77 C_DIS C_DIS
:ENDFOLD
:FOLD LIN P78 CONT Vel=1 m/s CPDAT77 Tool[10]:b1 Base[14]:b1;% {PE}%R 8.3.44,%MKUKATPBASIS,%CMOVE,%VLIN,%P
1:LIN, 2:P78, 3:C_DIS C_DIS, 5:1, 7:CPDAT77
$BWDSTART=FALSE
LDAT_ACT=LCPDAT77
FDAT_ACT=FP78
BAS(#CP_PARAMS,1)
LIN XP78 C_DIS C_DIS
:ENDFOLD
:FOLD LIN P79 CONT Vel=1 m/s CPDAT78 Tool[10]:b1 Base[14]:b1;% {PE}%R 8.3.44,%MKUKATPBASIS,%CMOVE,%VLIN,%P
1:LIN, 2:P79, 3:C_DIS C_DIS, 5:1, 7:CPDAT78
$BWDSTART=FALSE
LDAT_ACT=LCPDAT78
FDAT_ACT=FP79
BAS(#CP_PARAMS,1)
LIN XP79 C_DIS C_DIS
:ENDFOLD
:FOLD LIN P80 CONT Vel=1 m/s CPDAT79 Tool[10]:b1 Base[14]:b1;% {PE}%R 8.3.44,%MKUKATPBASIS,%CMOVE,%VLIN,%P
1:LIN, 2:P80, 3:C_DIS C_DIS, 5:1, 7:CPDAT79
$BWDSTART=FALSE
LDAT_ACT=LCPDAT79
FDAT_ACT=FP80
BAS(#CP_PARAMS,1)
LIN XP80 C_DIS C_DIS
:ENDFOLD
:FOLD LIN P81 CONT Vel=1 m/s CPDAT80 Tool[10]:b1 Base[14]:b1;% {PE}%R 8.3.44,%MKUKATPBASIS,%CMOVE,%VLIN,%P
1:LIN, 2:P81, 3:C_DIS C_DIS, 5:1, 7:CPDAT80
$BWDSTART=FALSE
LDAT_ACT=LCPDAT80
FDAT_ACT=FP81
BAS(#CP_PARAMS,1)
LIN XP81 C_DIS C_DIS
:ENDFOLD
:FOLD LIN P82 CONT Vel=1 m/s CPDAT81 Tool[10]:b1 Base[14]:b1;% {PE}%R 8.3.44,%MKUKATPBASIS,%CMOVE,%VLIN,%P
1:LIN, 2:P82, 3:C_DIS C_DIS, 5:1, 7:CPDAT81
$BWDSTART=FALSE
LDAT_ACT=LCPDAT81
FDAT_ACT=FP82
BAS(#CP_PARAMS,1)
LIN XP82 C_DIS C_DIS
:ENDFOLD
:FOLD LIN P83 CONT Vel=1 m/s CPDAT82 Tool[10]:b1 Base[14]:b1;% {PE}%R 8.3.44,%MKUKATPBASIS,%CMOVE,%VLIN,%P
1:LIN, 2:P83, 3:C_DIS C_DIS, 5:1, 7:CPDAT82
$BWDSTART=FALSE
LDAT_ACT=LCPDAT82
FDAT_ACT=FP83
BAS(#CP_PARAMS,1)
LIN XP83 C_DIS C_DIS
:ENDFOLD
:FOLD LIN P84 CONT Vel=1 m/s CPDAT83 Tool[10]:b1 Base[14]:b1;% {PE}%R 8.3.44,%MKUKATPBASIS,%CMOVE,%VLIN,%P
1:LIN, 2:P84, 3:C_DIS C_DIS, 5:1, 7:CPDAT83
$BWDSTART=FALSE

```

```

LDAT_ACT=LCPDAT83
FDAT_ACT=FP84
BAS(#CP_PARAMS,1)
LIN XP84 C_DIS C_DIS
:ENDFOLD
:FOLD LIN P85 CONT Vel=1 m/s CPDAT84 Tool[10]:b1 Base[14]:b1;% {PE}%R 8.3.44,%MKUKATPBASIS,%CMOVE,%VLIN,%P
1:LIN, 2:P85, 3:C_DIS C_DIS, 5:1, 7:CPDAT84
$BWDSTART=FALSE
LDAT_ACT=LCPDAT84
FDAT_ACT=FP85
BAS(#CP_PARAMS,1)
LIN XP85 C_DIS C_DIS
:ENDFOLD
:FOLD LIN P86 CONT Vel=1 m/s CPDAT85 Tool[10]:b1 Base[14]:b1;% {PE}%R 8.3.44,%MKUKATPBASIS,%CMOVE,%VLIN,%P
1:LIN, 2:P86, 3:C_DIS C_DIS, 5:1, 7:CPDAT85
$BWDSTART=FALSE
LDAT_ACT=LCPDAT85
FDAT_ACT=FP86
BAS(#CP_PARAMS,1)
LIN XP86 C_DIS C_DIS
:ENDFOLD
:FOLD LIN P87 CONT Vel=1 m/s CPDAT86 Tool[10]:b1 Base[14]:b1;% {PE}%R 8.3.44,%MKUKATPBASIS,%CMOVE,%VLIN,%P
1:LIN, 2:P87, 3:C_DIS C_DIS, 5:1, 7:CPDAT86
$BWDSTART=FALSE
LDAT_ACT=LCPDAT86
FDAT_ACT=FP87
BAS(#CP_PARAMS,1)
LIN XP87 C_DIS C_DIS
:ENDFOLD
:FOLD LIN P88 CONT Vel=1 m/s CPDAT87 Tool[10]:b1 Base[14]:b1;% {PE}%R 8.3.44,%MKUKATPBASIS,%CMOVE,%VLIN,%P
1:LIN, 2:P88, 3:C_DIS C_DIS, 5:1, 7:CPDAT87
$BWDSTART=FALSE
LDAT_ACT=LCPDAT87
FDAT_ACT=FP88
BAS(#CP_PARAMS,1)
LIN XP88 C_DIS C_DIS
:ENDFOLD
:FOLD LIN P89 CONT Vel=1 m/s CPDAT88 Tool[10]:b1 Base[14]:b1;% {PE}%R 8.3.44,%MKUKATPBASIS,%CMOVE,%VLIN,%P
1:LIN, 2:P89, 3:C_DIS C_DIS, 5:1, 7:CPDAT88
$BWDSTART=FALSE
LDAT_ACT=LCPDAT88
FDAT_ACT=FP89
BAS(#CP_PARAMS,1)
LIN XP89 C_DIS C_DIS
:ENDFOLD
:FOLD LIN P90 CONT Vel=1 m/s CPDAT89 Tool[10]:b1 Base[14]:b1;% {PE}%R 8.3.44,%MKUKATPBASIS,%CMOVE,%VLIN,%P
1:LIN, 2:P90, 3:C_DIS C_DIS, 5:1, 7:CPDAT89
$BWDSTART=FALSE
LDAT_ACT=LCPDAT89
FDAT_ACT=FP90
BAS(#CP_PARAMS,1)
LIN XP90 C_DIS C_DIS
:ENDFOLD
:FOLD LIN P91 CONT Vel=1 m/s CPDAT90 Tool[10]:b1 Base[14]:b1;% {PE}%R 8.3.44,%MKUKATPBASIS,%CMOVE,%VLIN,%P
1:LIN, 2:P91, 3:C_DIS C_DIS, 5:1, 7:CPDAT90
$BWDSTART=FALSE
LDAT_ACT=LCPDAT90
FDAT_ACT=FP91
BAS(#CP_PARAMS,1)
LIN XP91 C_DIS C_DIS
:ENDFOLD
:FOLD LIN P92 CONT Vel=1 m/s CPDAT91 Tool[10]:b1 Base[14]:b1;% {PE}%R 8.3.44,%MKUKATPBASIS,%CMOVE,%VLIN,%P
1:LIN, 2:P92, 3:C_DIS C_DIS, 5:1, 7:CPDAT91
$BWDSTART=FALSE
LDAT_ACT=LCPDAT91
FDAT_ACT=FP92
BAS(#CP_PARAMS,1)
LIN XP92 C_DIS C_DIS
:ENDFOLD
:FOLD LIN P93 CONT Vel=1 m/s CPDAT92 Tool[10]:b1 Base[14]:b1;% {PE}%R 8.3.44,%MKUKATPBASIS,%CMOVE,%VLIN,%P
1:LIN, 2:P93, 3:C_DIS C_DIS, 5:1, 7:CPDAT92
$BWDSTART=FALSE
LDAT_ACT=LCPDAT92
FDAT_ACT=FP93
BAS(#CP_PARAMS,1)

```

```

LIN XP93 C_DIS C_DIS
:ENDFOLD
:FOLD LIN P94 CONT Vel=1 m/s CPDAT93 Tool[10]:b1 Base[14]:b1;%{PE}%R 8.3.44,%MKUKATPBASIS,%CMOVE,%VLIN,%P
1:LIN, 2:P94, 3:C_DIS C_DIS, 5:1, 7:CPDAT93
$BWDSTART=FALSE
LDAT_ACT=LCPDAT93
FDAT_ACT=FP94
BAS(#CP_PARAMS,1)
LIN XP94 C_DIS C_DIS
:ENDFOLD
:FOLD LIN P95 CONT Vel=1 m/s CPDAT94 Tool[10]:b1 Base[14]:b1;%{PE}%R 8.3.44,%MKUKATPBASIS,%CMOVE,%VLIN,%P
1:LIN, 2:P95, 3:C_DIS C_DIS, 5:1, 7:CPDAT94
$BWDSTART=FALSE
LDAT_ACT=LCPDAT94
FDAT_ACT=FP95
BAS(#CP_PARAMS,1)
LIN XP95 C_DIS C_DIS
:ENDFOLD
:FOLD LIN P96 CONT Vel=1 m/s CPDAT95 Tool[10]:b1 Base[14]:b1;%{PE}%R 8.3.44,%MKUKATPBASIS,%CMOVE,%VLIN,%P
1:LIN, 2:P96, 3:C_DIS C_DIS, 5:1, 7:CPDAT95
$BWDSTART=FALSE
LDAT_ACT=LCPDAT95
FDAT_ACT=FP96
BAS(#CP_PARAMS,1)
LIN XP96 C_DIS C_DIS
:ENDFOLD
:FOLD LIN P97 CONT Vel=1 m/s CPDAT96 Tool[10]:b1 Base[14]:b1;%{PE}%R 8.3.44,%MKUKATPBASIS,%CMOVE,%VLIN,%P
1:LIN, 2:P97, 3:C_DIS C_DIS, 5:1, 7:CPDAT96
$BWDSTART=FALSE
LDAT_ACT=LCPDAT96
FDAT_ACT=FP97
BAS(#CP_PARAMS,1)
LIN XP97 C_DIS C_DIS
:ENDFOLD
:FOLD LIN P99 CONT Vel=1 m/s CPDAT98 Tool[10]:b1 Base[14]:b1;%{PE}%R 8.3.44,%MKUKATPBASIS,%CMOVE,%VLIN,%P
1:LIN, 2:P99, 3:C_DIS C_DIS, 5:1, 7:CPDAT98
$BWDSTART=FALSE
LDAT_ACT=LCPDAT98
FDAT_ACT=FP99
BAS(#CP_PARAMS,1)
LIN XP99 C_DIS C_DIS
:ENDFOLD
:FOLD LIN P100 CONT Vel=1 m/s CPDAT99 Tool[10]:b1 Base[14]:b1;%{PE}%R 8.3.44,%MKUKATPBASIS,%CMOVE,%VLIN,%P
1:LIN, 2:P100, 3:C_DIS C_DIS, 5:1, 7:CPDAT99
$BWDSTART=FALSE
LDAT_ACT=LCPDAT99
FDAT_ACT=FP100
BAS(#CP_PARAMS,1)
LIN XP100 C_DIS C_DIS
:ENDFOLD
:FOLD LIN P102 CONT Vel=1 m/s CPDAT101 Tool[10]:b1 Base[14]:b1;%{PE}%R 8.3.44,%MKUKATPBASIS,%CMOVE,%VLIN,%P
1:LIN, 2:P102, 3:C_DIS C_DIS, 5:1, 7:CPDAT101
$BWDSTART=FALSE
LDAT_ACT=LCPDAT101
FDAT_ACT=FP102
BAS(#CP_PARAMS,1)
LIN XP102 C_DIS C_DIS
:ENDFOLD
:FOLD LIN P103 CONT Vel=1 m/s CPDAT102 Tool[10]:b1 Base[14]:b1;%{PE}%R 8.3.44,%MKUKATPBASIS,%CMOVE,%VLIN,%P
1:LIN, 2:P103, 3:C_DIS C_DIS, 5:1, 7:CPDAT102
$BWDSTART=FALSE
LDAT_ACT=LCPDAT102
FDAT_ACT=FP103
BAS(#CP_PARAMS,1)
LIN XP103 C_DIS C_DIS
:ENDFOLD
:FOLD LIN P104 CONT Vel=1 m/s CPDAT103 Tool[10]:b1 Base[14]:b1;%{PE}%R 8.3.44,%MKUKATPBASIS,%CMOVE,%VLIN,%P
1:LIN, 2:P104, 3:C_DIS C_DIS, 5:1, 7:CPDAT103
$BWDSTART=FALSE
LDAT_ACT=LCPDAT103
FDAT_ACT=FP104
BAS(#CP_PARAMS,1)
LIN XP104 C_DIS C_DIS
:ENDFOLD

```

```
;FOLD LIN P105 CONT Vel=1 m/s CPDAT104 Tool[10]:b1 Base[14]:b1;%{PE}%R 8.3.44,%MKUKATPBASIS,%CMOVE,%VLIN,%P
1:LIN, 2:P105, 3:C_DIS C_DIS, 5:1, 7:CPDAT104
$BWDSTART=FALSE
LDAT_ACT=LCPDAT104
FDAT_ACT=FP105
BAS(#CP_PARAMS,1)
LIN XP105 C_DIS C_DIS
;ENDFOLD
;FOLD LIN P106 CONT Vel=1 m/s CPDAT105 Tool[10]:b1 Base[14]:b1;%{PE}%R 8.3.44,%MKUKATPBASIS,%CMOVE,%VLIN,%P
1:LIN, 2:P106, 3:C_DIS C_DIS, 5:1, 7:CPDAT105
$BWDSTART=FALSE
LDAT_ACT=LCPDAT105
FDAT_ACT=FP106
BAS(#CP_PARAMS,1)
LIN XP106 C_DIS C_DIS
;ENDFOLD
;FOLD LIN P107 CONT Vel=1 m/s CPDAT106 Tool[10]:b1 Base[14]:b1;%{PE}%R 8.3.44,%MKUKATPBASIS,%CMOVE,%VLIN,%P
1:LIN, 2:P107, 3:C_DIS C_DIS, 5:1, 7:CPDAT106
$BWDSTART=FALSE
LDAT_ACT=LCPDAT106
FDAT_ACT=FP107
BAS(#CP_PARAMS,1)
LIN XP107 C_DIS C_DIS
;ENDFOLD
;FOLD LIN P108 CONT Vel=1 m/s CPDAT107 Tool[10]:b1 Base[14]:b1;%{PE}%R 8.3.44,%MKUKATPBASIS,%CMOVE,%VLIN,%P
1:LIN, 2:P108, 3:C_DIS C_DIS, 5:1, 7:CPDAT107
$BWDSTART=FALSE
LDAT_ACT=LCPDAT107
FDAT_ACT=FP108
BAS(#CP_PARAMS,1)
LIN XP108 C_DIS C_DIS
;ENDFOLD
;FOLD LIN P110 CONT Vel=1 m/s CPDAT109 Tool[10]:b1 Base[14]:b1;%{PE}%R 8.3.44,%MKUKATPBASIS,%CMOVE,%VLIN,%P
1:LIN, 2:P110, 3:C_DIS C_DIS, 5:1, 7:CPDAT109
$BWDSTART=FALSE
LDAT_ACT=LCPDAT109
FDAT_ACT=FP110
BAS(#CP_PARAMS,1)
LIN XP110 C_DIS C_DIS
;ENDFOLD
;FOLD LIN P111 CONT Vel=1 m/s CPDAT110 Tool[10]:b1 Base[14]:b1;%{PE}%R 8.3.44,%MKUKATPBASIS,%CMOVE,%VLIN,%P
1:LIN, 2:P111, 3:C_DIS C_DIS, 5:1, 7:CPDAT110
$BWDSTART=FALSE
LDAT_ACT=LCPDAT110
FDAT_ACT=FP111
BAS(#CP_PARAMS,1)
LIN XP111 C_DIS C_DIS
;ENDFOLD
;FOLD LIN P114 CONT Vel=1 m/s CPDAT113 Tool[10]:b1 Base[14]:b1;%{PE}%R 8.3.44,%MKUKATPBASIS,%CMOVE,%VLIN,%P
1:LIN, 2:P114, 3:C_DIS C_DIS, 5:1, 7:CPDAT113
$BWDSTART=FALSE
LDAT_ACT=LCPDAT113
FDAT_ACT=FP114
BAS(#CP_PARAMS,1)
LIN XP114 C_DIS C_DIS
;ENDFOLD
;FOLD LIN P115 CONT Vel=1 m/s CPDAT114 Tool[10]:b1 Base[14]:b1;%{PE}%R 8.3.44,%MKUKATPBASIS,%CMOVE,%VLIN,%P
1:LIN, 2:P115, 3:C_DIS C_DIS, 5:1, 7:CPDAT114
$BWDSTART=FALSE
LDAT_ACT=LCPDAT114
FDAT_ACT=FP115
BAS(#CP_PARAMS,1)
LIN XP115 C_DIS C_DIS
;ENDFOLD
;FOLD LIN P116 CONT Vel=1 m/s CPDAT115 Tool[10]:b1 Base[14]:b1;%{PE}%R 8.3.44,%MKUKATPBASIS,%CMOVE,%VLIN,%P
1:LIN, 2:P116, 3:C_DIS C_DIS, 5:1, 7:CPDAT115
$BWDSTART=FALSE
LDAT_ACT=LCPDAT115
FDAT_ACT=FP116
BAS(#CP_PARAMS,1)
LIN XP116 C_DIS C_DIS
;ENDFOLD
;FOLD LIN P117 CONT Vel=1 m/s CPDAT116 Tool[10]:b1 Base[14]:b1;%{PE}%R 8.3.44,%MKUKATPBASIS,%CMOVE,%VLIN,%P
1:LIN, 2:P117, 3:C_DIS C_DIS, 5:1, 7:CPDAT116
$BWDSTART=FALSE
```

```

LDAT_ACT=LCPDAT116
FDAT_ACT=FP117
BAS(#CP_PARAMS,1)
LIN XP117 C_DIS C_DIS
:ENDFOLD
:FOLD LIN P119 CONT Vel=1 m/s CPDAT118 Tool[10]:b1 Base[14]:b1;%{PE}%R 8.3.44,%MKUKATPBASIS,%CMOVE,%VLIN,%P
1:LIN, 2:P119, 3:C_DIS C_DIS, 5:1, 7:CPDAT118
$BWDSTART=FALSE
LDAT_ACT=LCPDAT118
FDAT_ACT=FP119
BAS(#CP_PARAMS,1)
LIN XP119 C_DIS C_DIS
:ENDFOLD
:FOLD LIN P120 CONT Vel=1 m/s CPDAT119 Tool[10]:b1 Base[14]:b1;%{PE}%R 8.3.44,%MKUKATPBASIS,%CMOVE,%VLIN,%P
1:LIN, 2:P120, 3:C_DIS C_DIS, 5:1, 7:CPDAT119
$BWDSTART=FALSE
LDAT_ACT=LCPDAT119
FDAT_ACT=FP120
BAS(#CP_PARAMS,1)
LIN XP120 C_DIS C_DIS
:ENDFOLD
:FOLD LIN P121 CONT Vel=1 m/s CPDAT120 Tool[10]:b1 Base[14]:b1;%{PE}%R 8.3.44,%MKUKATPBASIS,%CMOVE,%VLIN,%P
1:LIN, 2:P121, 3:C_DIS C_DIS, 5:1, 7:CPDAT120
$BWDSTART=FALSE
LDAT_ACT=LCPDAT120
FDAT_ACT=FP121
BAS(#CP_PARAMS,1)
LIN XP121 C_DIS C_DIS
:ENDFOLD
:FOLD LIN P122 CONT Vel=1 m/s CPDAT121 Tool[10]:b1 Base[14]:b1;%{PE}%R 8.3.44,%MKUKATPBASIS,%CMOVE,%VLIN,%P
1:LIN, 2:P122, 3:C_DIS C_DIS, 5:1, 7:CPDAT121
$BWDSTART=FALSE
LDAT_ACT=LCPDAT121
FDAT_ACT=FP122
BAS(#CP_PARAMS,1)
LIN XP122 C_DIS C_DIS
:ENDFOLD
:FOLD LIN P123 CONT Vel=1 m/s CPDAT122 Tool[10]:b1 Base[14]:b1;%{PE}%R 8.3.44,%MKUKATPBASIS,%CMOVE,%VLIN,%P
1:LIN, 2:P123, 3:C_DIS C_DIS, 5:1, 7:CPDAT122
$BWDSTART=FALSE
LDAT_ACT=LCPDAT122
FDAT_ACT=FP123
BAS(#CP_PARAMS,1)
LIN XP123 C_DIS C_DIS
:ENDFOLD
:FOLD LIN P124 CONT Vel=1 m/s CPDAT123 Tool[10]:b1 Base[14]:b1;%{PE}%R 8.3.44,%MKUKATPBASIS,%CMOVE,%VLIN,%P
1:LIN, 2:P124, 3:C_DIS C_DIS, 5:1, 7:CPDAT123
$BWDSTART=FALSE
LDAT_ACT=LCPDAT123
FDAT_ACT=FP124
BAS(#CP_PARAMS,1)
LIN XP124 C_DIS C_DIS
:ENDFOLD
:FOLD LIN P125 CONT Vel=1 m/s CPDAT124 Tool[10]:b1 Base[14]:b1;%{PE}%R 8.3.44,%MKUKATPBASIS,%CMOVE,%VLIN,%P
1:LIN, 2:P125, 3:C_DIS C_DIS, 5:1, 7:CPDAT124
$BWDSTART=FALSE
LDAT_ACT=LCPDAT124
FDAT_ACT=FP125
BAS(#CP_PARAMS,1)
LIN XP125 C_DIS C_DIS
:ENDFOLD
:FOLD LIN P126 CONT Vel=1 m/s CPDAT125 Tool[10]:b1 Base[14]:b1;%{PE}%R 8.3.44,%MKUKATPBASIS,%CMOVE,%VLIN,%P
1:LIN, 2:P126, 3:C_DIS C_DIS, 5:1, 7:CPDAT125
$BWDSTART=FALSE
LDAT_ACT=LCPDAT125
FDAT_ACT=FP126
BAS(#CP_PARAMS,1)
LIN XP126 C_DIS C_DIS
:ENDFOLD
:FOLD LIN P127 CONT Vel=1 m/s CPDAT126 Tool[10]:b1 Base[14]:b1;%{PE}%R 8.3.44,%MKUKATPBASIS,%CMOVE,%VLIN,%P
1:LIN, 2:P127, 3:C_DIS C_DIS, 5:1, 7:CPDAT126
$BWDSTART=FALSE
LDAT_ACT=LCPDAT126
FDAT_ACT=FP127
BAS(#CP_PARAMS,1)

```

```

LIN XP127 C_DIS C_DIS
:ENDFOLD
:FOLD LIN P128 CONT Vel=1 m/s CPDAT127 Tool[10]:b1 Base[14]:b1;%{PE}%R 8.3.44,%MKUKATPBASIS,%CMOVE,%VLIN,%P
1:LIN, 2:P128, 3:C_DIS C_DIS, 5:1, 7:CPDAT127
$BWDSTART=FALSE
LDAT_ACT=LCPDAT127
FDAT_ACT=FP128
BAS(#CP_PARAMS,1)
LIN XP128 C_DIS C_DIS
:ENDFOLD
:FOLD LIN P129 CONT Vel=1 m/s CPDAT128 Tool[10]:b1 Base[14]:b1;%{PE}%R 8.3.44,%MKUKATPBASIS,%CMOVE,%VLIN,%P
1:LIN, 2:P129, 3:C_DIS C_DIS, 5:1, 7:CPDAT128
$BWDSTART=FALSE
LDAT_ACT=LCPDAT128
FDAT_ACT=FP129
BAS(#CP_PARAMS,1)
LIN XP129 C_DIS C_DIS
:ENDFOLD
:FOLD LIN P130 CONT Vel=1 m/s CPDAT129 Tool[10]:b1 Base[14]:b1;%{PE}%R 8.3.44,%MKUKATPBASIS,%CMOVE,%VLIN,%P
1:LIN, 2:P130, 3:C_DIS C_DIS, 5:1, 7:CPDAT129
$BWDSTART=FALSE
LDAT_ACT=LCPDAT129
FDAT_ACT=FP130
BAS(#CP_PARAMS,1)
LIN XP130 C_DIS C_DIS
:ENDFOLD
:FOLD LIN P131 CONT Vel=1 m/s CPDAT130 Tool[10]:b1 Base[14]:b1;%{PE}%R 8.3.44,%MKUKATPBASIS,%CMOVE,%VLIN,%P
1:LIN, 2:P131, 3:C_DIS C_DIS, 5:1, 7:CPDAT130
$BWDSTART=FALSE
LDAT_ACT=LCPDAT130
FDAT_ACT=FP131
BAS(#CP_PARAMS,1)
LIN XP131 C_DIS C_DIS
:ENDFOLD
:FOLD LIN P133 CONT Vel=1 m/s CPDAT132 Tool[10]:b1 Base[14]:b1 CD;%{PE}%R
8.3.44,%MKUKATPBASIS,%CMOVE,%VLIN,%P 1:LIN, 2:P133, 3:C_DIS C_DIS, 5:1, 7:CPDAT132
$BWDSTART=FALSE
LDAT_ACT=LCPDAT132
FDAT_ACT=FP133
BAS(#CP_PARAMS,1)
TQM_FIFO_READ(TM2)
TRIGGER WHEN DISTANCE=0 DELAY=TQM_DLY() DO iTQM_TRIGGERID=2
TRIGGER WHEN DISTANCE=0 DELAY=TQM_DLY() DO TQM_START_MON(TM2) PRIO = -1
TRIGGER WHEN DISTANCE=1 DELAY=0 DO TQM_SWAP_VALUES(TM2) PRIO = -1
LIN XP133 C_DIS C_DIS
:ENDFOLD
:FOLD LIN P134 CONT Vel=1 m/s CPDAT133 Tool[10]:b1 Base[14]:b1 CD;%{PE}%R
8.3.44,%MKUKATPBASIS,%CMOVE,%VLIN,%P 1:LIN, 2:P134, 3:C_DIS C_DIS, 5:1, 7:CPDAT133
$BWDSTART=FALSE
LDAT_ACT=LCPDAT133
FDAT_ACT=FP134
BAS(#CP_PARAMS,1)
TQM_FIFO_READ(TM3)
TRIGGER WHEN DISTANCE=0 DELAY=TQM_DLY() DO iTQM_TRIGGERID=3
TRIGGER WHEN DISTANCE=0 DELAY=TQM_DLY() DO TQM_START_MON(TM3) PRIO = -1
TRIGGER WHEN DISTANCE=1 DELAY=0 DO TQM_SWAP_VALUES(TM3) PRIO = -1
LIN XP134 C_DIS C_DIS
:ENDFOLD
:FOLD LIN P135 CONT Vel=1 m/s CPDAT134 Tool[10]:b1 Base[14]:b1 CD;%{PE}%R
8.3.44,%MKUKATPBASIS,%CMOVE,%VLIN,%P 1:LIN, 2:P135, 3:C_DIS C_DIS, 5:1, 7:CPDAT134
$BWDSTART=FALSE
LDAT_ACT=LCPDAT134
FDAT_ACT=FP135
BAS(#CP_PARAMS,1)
TQM_FIFO_READ(TM4)
TRIGGER WHEN DISTANCE=0 DELAY=TQM_DLY() DO iTQM_TRIGGERID=4
TRIGGER WHEN DISTANCE=0 DELAY=TQM_DLY() DO TQM_START_MON(TM4) PRIO = -1
TRIGGER WHEN DISTANCE=1 DELAY=0 DO TQM_SWAP_VALUES(TM4) PRIO = -1
LIN XP135 C_DIS C_DIS
:ENDFOLD
:FOLD LIN P136 CONT Vel=1 m/s CPDAT135 Tool[10]:b1 Base[14]:b1 CD;%{PE}%R
8.3.44,%MKUKATPBASIS,%CMOVE,%VLIN,%P 1:LIN, 2:P136, 3:C_DIS C_DIS, 5:1, 7:CPDAT135
$BWDSTART=FALSE
LDAT_ACT=LCPDAT135
FDAT_ACT=FP136

```

```

BAS(#CP_PARAMS,1)
TQM_FIFO_READ(TM5)
TRIGGER WHEN DISTANCE=0 DELAY=TQM_DLY() DO iTQM_TRIGGERID=5
TRIGGER WHEN DISTANCE=0 DELAY=TQM_DLY() DO TQM_START_MON(TM5) PRIO = -1
TRIGGER WHEN DISTANCE=1 DELAY=0 DO TQM_SWAP_VALUES(TM5) PRIO = -1
LIN XP136 C_DIS C_DIS
:ENDFOLD
:FOLD LIN P137 CONT Vel=1 m/s CPDAT136 Tool[10]:b1 Base[14]:b1 CD;%{PE}%R
8.3.44,%MKUKATPBASIS,%CMOVE,%VLIN,%P 1:LIN, 2:P137, 3:C_DIS C_DIS, 5:1, 7:CPDAT136
$BWDSTART=FALSE
LDAT_ACT=LCPDAT136
FDAT_ACT=FP137
BAS(#CP_PARAMS,1)
TQM_FIFO_READ(TM6)
TRIGGER WHEN DISTANCE=0 DELAY=TQM_DLY() DO iTQM_TRIGGERID=6
TRIGGER WHEN DISTANCE=0 DELAY=TQM_DLY() DO TQM_START_MON(TM6) PRIO = -1
TRIGGER WHEN DISTANCE=1 DELAY=0 DO TQM_SWAP_VALUES(TM6) PRIO = -1
LIN XP137 C_DIS C_DIS
:ENDFOLD
:FOLD LIN P138 CONT Vel=1 m/s CPDAT137 Tool[10]:b1 Base[14]:b1 CD;%{PE}%R
8.3.44,%MKUKATPBASIS,%CMOVE,%VLIN,%P 1:LIN, 2:P138, 3:C_DIS C_DIS, 5:1, 7:CPDAT137
$BWDSTART=FALSE
LDAT_ACT=LCPDAT137
FDAT_ACT=FP138
BAS(#CP_PARAMS,1)
TQM_FIFO_READ(TM7)
TRIGGER WHEN DISTANCE=0 DELAY=TQM_DLY() DO iTQM_TRIGGERID=7
TRIGGER WHEN DISTANCE=0 DELAY=TQM_DLY() DO TQM_START_MON(TM7) PRIO = -1
TRIGGER WHEN DISTANCE=1 DELAY=0 DO TQM_SWAP_VALUES(TM7) PRIO = -1
LIN XP138 C_DIS C_DIS
:ENDFOLD
:FOLD LIN P139 CONT Vel=1 m/s CPDAT138 Tool[10]:b1 Base[14]:b1 CD;%{PE}%R
8.3.44,%MKUKATPBASIS,%CMOVE,%VLIN,%P 1:LIN, 2:P139, 3:C_DIS C_DIS, 5:1, 7:CPDAT138
$BWDSTART=FALSE
LDAT_ACT=LCPDAT138
FDAT_ACT=FP139
BAS(#CP_PARAMS,1)
TQM_FIFO_READ(TM8)
TRIGGER WHEN DISTANCE=0 DELAY=TQM_DLY() DO iTQM_TRIGGERID=8
TRIGGER WHEN DISTANCE=0 DELAY=TQM_DLY() DO TQM_START_MON(TM8) PRIO = -1
TRIGGER WHEN DISTANCE=1 DELAY=0 DO TQM_SWAP_VALUES(TM8) PRIO = -1
LIN XP139 C_DIS C_DIS
:ENDFOLD
:FOLD LIN P140 CONT Vel=1 m/s CPDAT139 Tool[10]:b1 Base[14]:b1 CD;%{PE}%R
8.3.44,%MKUKATPBASIS,%CMOVE,%VLIN,%P 1:LIN, 2:P140, 3:C_DIS C_DIS, 5:1, 7:CPDAT139
$BWDSTART=FALSE
LDAT_ACT=LCPDAT139
FDAT_ACT=FP140
BAS(#CP_PARAMS,1)
TQM_FIFO_READ(TM9)
TRIGGER WHEN DISTANCE=0 DELAY=TQM_DLY() DO iTQM_TRIGGERID=9
TRIGGER WHEN DISTANCE=0 DELAY=TQM_DLY() DO TQM_START_MON(TM9) PRIO = -1
TRIGGER WHEN DISTANCE=1 DELAY=0 DO TQM_SWAP_VALUES(TM9) PRIO = -1
LIN XP140 C_DIS C_DIS
:ENDFOLD
:FOLD LIN P141 CONT Vel=1 m/s CPDAT140 Tool[10]:b1 Base[14]:b1 CD;%{PE}%R
8.3.44,%MKUKATPBASIS,%CMOVE,%VLIN,%P 1:LIN, 2:P141, 3:C_DIS C_DIS, 5:1, 7:CPDAT140
$BWDSTART=FALSE
LDAT_ACT=LCPDAT140
FDAT_ACT=FP141
BAS(#CP_PARAMS,1)
TQM_FIFO_READ(TM10)
TRIGGER WHEN DISTANCE=0 DELAY=TQM_DLY() DO iTQM_TRIGGERID=10
TRIGGER WHEN DISTANCE=0 DELAY=TQM_DLY() DO TQM_START_MON(TM10) PRIO = -1
TRIGGER WHEN DISTANCE=1 DELAY=0 DO TQM_SWAP_VALUES(TM10) PRIO = -1
LIN XP141 C_DIS C_DIS
:ENDFOLD
:FOLD LIN P142 CONT Vel=1 m/s CPDAT141 Tool[10]:b1 Base[14]:b1 CD;%{PE}%R
8.3.44,%MKUKATPBASIS,%CMOVE,%VLIN,%P 1:LIN, 2:P142, 3:C_DIS C_DIS, 5:1, 7:CPDAT141
$BWDSTART=FALSE
LDAT_ACT=LCPDAT141
FDAT_ACT=FP142
BAS(#CP_PARAMS,1)
TQM_FIFO_READ(TM11)
TRIGGER WHEN DISTANCE=0 DELAY=TQM_DLY() DO iTQM_TRIGGERID=11

```

```

TRIGGER WHEN DISTANCE=0 DELAY=TQM_DLY() DO TQM_START_MON(TM11) PRIO = -1
TRIGGER WHEN DISTANCE=1 DELAY=0 DO TQM_SWAP_VALUES(TM11) PRIO = -1
LIN XP142 C_DIS C_DIS
;ENDFOLD
;FOLD   LIN    P143   CONT    Vel=1    m/s    CPDAT142   Tool[10]:b1   Base[14]:b1   CD;%{PE}%R
8.3.44,%MKUKATPBASIS,%CMOVE,%VLIN,%P 1:LIN, 2:P143, 3:C_DIS C_DIS, 5:1, 7:CPDAT142
$BWDSTART=FALSE
LDAT_ACT=LCPDAT142
FDAT_ACT=FP143
BAS(#CP_PARAMS,1)
TQM_FIFO_READ(TM12)
TRIGGER WHEN DISTANCE=0 DELAY=TQM_DLY() DO iTQM_TRIGGERID=12
TRIGGER WHEN DISTANCE=0 DELAY=TQM_DLY() DO TQM_START_MON(TM12) PRIO = -1
TRIGGER WHEN DISTANCE=1 DELAY=0 DO TQM_SWAP_VALUES(TM12) PRIO = -1
LIN XP143 C_DIS C_DIS
;ENDFOLD
;FOLD   LIN    P144   CONT    Vel=1    m/s    CPDAT143   Tool[10]:b1   Base[14]:b1   CD;%{PE}%R
8.3.44,%MKUKATPBASIS,%CMOVE,%VLIN,%P 1:LIN, 2:P144, 3:C_DIS C_DIS, 5:1, 7:CPDAT143
$BWDSTART=FALSE
LDAT_ACT=LCPDAT143
FDAT_ACT=FP144
BAS(#CP_PARAMS,1)
TQM_FIFO_READ(TM13)
TRIGGER WHEN DISTANCE=0 DELAY=TQM_DLY() DO iTQM_TRIGGERID=13
TRIGGER WHEN DISTANCE=0 DELAY=TQM_DLY() DO TQM_START_MON(TM13) PRIO = -1
TRIGGER WHEN DISTANCE=1 DELAY=0 DO TQM_SWAP_VALUES(TM13) PRIO = -1
LIN XP144 C_DIS C_DIS
;ENDFOLD
;FOLD   LIN    P145   CONT    Vel=1    m/s    CPDAT144   Tool[10]:b1   Base[14]:b1   CD;%{PE}%R
8.3.44,%MKUKATPBASIS,%CMOVE,%VLIN,%P 1:LIN, 2:P145, 3:C_DIS C_DIS, 5:1, 7:CPDAT144
$BWDSTART=FALSE
LDAT_ACT=LCPDAT144
FDAT_ACT=FP145
BAS(#CP_PARAMS,1)
TQM_FIFO_READ(TM14)
TRIGGER WHEN DISTANCE=0 DELAY=TQM_DLY() DO iTQM_TRIGGERID=14
TRIGGER WHEN DISTANCE=0 DELAY=TQM_DLY() DO TQM_START_MON(TM14) PRIO = -1
TRIGGER WHEN DISTANCE=1 DELAY=0 DO TQM_SWAP_VALUES(TM14) PRIO = -1
LIN XP145 C_DIS C_DIS
;ENDFOLD
;FOLD   LIN    P146   CONT    Vel=1    m/s    CPDAT145   Tool[10]:b1   Base[14]:b1   CD;%{PE}%R
8.3.44,%MKUKATPBASIS,%CMOVE,%VLIN,%P 1:LIN, 2:P146, 3:C_DIS C_DIS, 5:1, 7:CPDAT145
$BWDSTART=FALSE
LDAT_ACT=LCPDAT145
FDAT_ACT=FP146
BAS(#CP_PARAMS,1)
TQM_FIFO_READ(TM15)
TRIGGER WHEN DISTANCE=0 DELAY=TQM_DLY() DO iTQM_TRIGGERID=15
TRIGGER WHEN DISTANCE=0 DELAY=TQM_DLY() DO TQM_START_MON(TM15) PRIO = -1
TRIGGER WHEN DISTANCE=1 DELAY=0 DO TQM_SWAP_VALUES(TM15) PRIO = -1
LIN XP146 C_DIS C_DIS
;ENDFOLD
;FOLD   LIN    P147   CONT    Vel=1    m/s    CPDAT146   Tool[10]:b1   Base[14]:b1   CD;%{PE}%R
8.3.44,%MKUKATPBASIS,%CMOVE,%VLIN,%P 1:LIN, 2:P147, 3:C_DIS C_DIS, 5:1, 7:CPDAT146
$BWDSTART=FALSE
LDAT_ACT=LCPDAT146
FDAT_ACT=FP147
BAS(#CP_PARAMS,1)
TQM_FIFO_READ(TM16)
TRIGGER WHEN DISTANCE=0 DELAY=TQM_DLY() DO iTQM_TRIGGERID=16
TRIGGER WHEN DISTANCE=0 DELAY=TQM_DLY() DO TQM_START_MON(TM16) PRIO = -1
TRIGGER WHEN DISTANCE=1 DELAY=0 DO TQM_SWAP_VALUES(TM16) PRIO = -1
LIN XP147 C_DIS C_DIS
;ENDFOLD
;FOLD   LIN    P148   CONT    Vel=1    m/s    CPDAT147   Tool[10]:b1   Base[14]:b1   CD;%{PE}%R
8.3.44,%MKUKATPBASIS,%CMOVE,%VLIN,%P 1:LIN, 2:P148, 3:C_DIS C_DIS, 5:1, 7:CPDAT147
$BWDSTART=FALSE
LDAT_ACT=LCPDAT147
FDAT_ACT=FP148
BAS(#CP_PARAMS,1)
TQM_FIFO_READ(TM17)
TRIGGER WHEN DISTANCE=0 DELAY=TQM_DLY() DO iTQM_TRIGGERID=17
TRIGGER WHEN DISTANCE=0 DELAY=TQM_DLY() DO TQM_START_MON(TM17) PRIO = -1
TRIGGER WHEN DISTANCE=1 DELAY=0 DO TQM_SWAP_VALUES(TM17) PRIO = -1
LIN XP148 C_DIS C_DIS

```



```

:ENDFOLD
:FOLD   LIN      P149   CONT   Vel=1   m/s   CPDAT148   Tool[10]:b1   Base[14]:b1   CD;%{PE}%R
8.3.44,%MKUKATPBASIS,%CMOVE,%VLIN,%P 1:LIN, 2:P149, 3:C_DIS C_DIS, 5:1, 7:CPDAT148
$BWDSTART=FALSE
LDAT_ACT=LCPDAT148
FDAT_ACT=FP149
BAS(#CP_PARAMS,1)
TQM_FIFO_READ(TM18)
TRIGGER WHEN DISTANCE=0 DELAY=TQM_DLY() DO iTQM_TRIGGERID=18
TRIGGER WHEN DISTANCE=0 DELAY=TQM_DLY() DO TQM_START_MON(TM18) PRIO = -1
TRIGGER WHEN DISTANCE=1 DELAY=0 DO TQM_SWAP_VALUES(TM18) PRIO = -1
LIN XP149 C_DIS C_DIS
:ENDFOLD
:FOLD   LIN      P150   CONT   Vel=1   m/s   CPDAT149   Tool[10]:b1   Base[14]:b1   CD;%{PE}%R
8.3.44,%MKUKATPBASIS,%CMOVE,%VLIN,%P 1:LIN, 2:P150, 3:C_DIS C_DIS, 5:1, 7:CPDAT149
$BWDSTART=FALSE
LDAT_ACT=LCPDAT149
FDAT_ACT=FP150
BAS(#CP_PARAMS,1)
TQM_FIFO_READ(TM19)
TRIGGER WHEN DISTANCE=0 DELAY=TQM_DLY() DO iTQM_TRIGGERID=19
TRIGGER WHEN DISTANCE=0 DELAY=TQM_DLY() DO TQM_START_MON(TM19) PRIO = -1
TRIGGER WHEN DISTANCE=1 DELAY=0 DO TQM_SWAP_VALUES(TM19) PRIO = -1
LIN XP150 C_DIS C_DIS
:ENDFOLD
:FOLD   LIN      P151   CONT   Vel=1   m/s   CPDAT150   Tool[10]:b1   Base[14]:b1   CD;%{PE}%R
8.3.44,%MKUKATPBASIS,%CMOVE,%VLIN,%P 1:LIN, 2:P151, 3:C_DIS C_DIS, 5:1, 7:CPDAT150
$BWDSTART=FALSE
LDAT_ACT=LCPDAT150
FDAT_ACT=FP151
BAS(#CP_PARAMS,1)
TQM_FIFO_READ(TM20)
TRIGGER WHEN DISTANCE=0 DELAY=TQM_DLY() DO iTQM_TRIGGERID=20
TRIGGER WHEN DISTANCE=0 DELAY=TQM_DLY() DO TQM_START_MON(TM20) PRIO = -1
TRIGGER WHEN DISTANCE=1 DELAY=0 DO TQM_SWAP_VALUES(TM20) PRIO = -1
LIN XP151 C_DIS C_DIS
:ENDFOLD
:FOLD   LIN      P152   CONT   Vel=1   m/s   CPDAT151   Tool[10]:b1   Base[14]:b1   CD;%{PE}%R
8.3.44,%MKUKATPBASIS,%CMOVE,%VLIN,%P 1:LIN, 2:P152, 3:C_DIS C_DIS, 5:1, 7:CPDAT151
$BWDSTART=FALSE
LDAT_ACT=LCPDAT151
FDAT_ACT=FP152
BAS(#CP_PARAMS,1)
TQM_FIFO_READ(TM21)
TRIGGER WHEN DISTANCE=0 DELAY=TQM_DLY() DO iTQM_TRIGGERID=21
TRIGGER WHEN DISTANCE=0 DELAY=TQM_DLY() DO TQM_START_MON(TM21) PRIO = -1
TRIGGER WHEN DISTANCE=1 DELAY=0 DO TQM_SWAP_VALUES(TM21) PRIO = -1
LIN XP152 C_DIS C_DIS
:ENDFOLD
:FOLD   LIN      P153   CONT   Vel=1   m/s   CPDAT152   Tool[10]:b1   Base[14]:b1   CD;%{PE}%R
8.3.44,%MKUKATPBASIS,%CMOVE,%VLIN,%P 1:LIN, 2:P153, 3:C_DIS C_DIS, 5:1, 7:CPDAT152
$BWDSTART=FALSE
LDAT_ACT=LCPDAT152
FDAT_ACT=FP153
BAS(#CP_PARAMS,1)
TQM_FIFO_READ(TM22)
TRIGGER WHEN DISTANCE=0 DELAY=TQM_DLY() DO iTQM_TRIGGERID=22
TRIGGER WHEN DISTANCE=0 DELAY=TQM_DLY() DO TQM_START_MON(TM22) PRIO = -1
TRIGGER WHEN DISTANCE=1 DELAY=0 DO TQM_SWAP_VALUES(TM22) PRIO = -1
LIN XP153 C_DIS C_DIS
:ENDFOLD
:FOLD   LIN      P154   CONT   Vel=1   m/s   CPDAT153   Tool[10]:b1   Base[14]:b1   CD;%{PE}%R
8.3.44,%MKUKATPBASIS,%CMOVE,%VLIN,%P 1:LIN, 2:P154, 3:C_DIS C_DIS, 5:1, 7:CPDAT153
$BWDSTART=FALSE
LDAT_ACT=LCPDAT153
FDAT_ACT=FP154
BAS(#CP_PARAMS,1)
TQM_FIFO_READ(TM23)
TRIGGER WHEN DISTANCE=0 DELAY=TQM_DLY() DO iTQM_TRIGGERID=23
TRIGGER WHEN DISTANCE=0 DELAY=TQM_DLY() DO TQM_START_MON(TM23) PRIO = -1
TRIGGER WHEN DISTANCE=1 DELAY=0 DO TQM_SWAP_VALUES(TM23) PRIO = -1
LIN XP154 C_DIS C_DIS
:ENDFOLD
:FOLD   LIN      P155   CONT   Vel=1   m/s   CPDAT154   Tool[10]:b1   Base[14]:b1   CD;%{PE}%R
8.3.44,%MKUKATPBASIS,%CMOVE,%VLIN,%P 1:LIN, 2:P155, 3:C_DIS C_DIS, 5:1, 7:CPDAT154

```

```

$BWDSTART=FALSE
LDAT_ACT=LCPDAT154
FDAT_ACT=FP155
BAS(#CP_PARAMS,1)
TQM_FIFO_READ(TM24)
TRIGGER WHEN DISTANCE=0 DELAY=TQM_DLY() DO iTQM_TRIGGERID=24
TRIGGER WHEN DISTANCE=0 DELAY=TQM_DLY() DO TQM_START_MON(TM24) PRIO = -1
TRIGGER WHEN DISTANCE=1 DELAY=0 DO TQM_SWAP_VALUES(TM24) PRIO = -1
LIN XP155 C_DIS C_DIS
:ENDFOLD
:FOLD   LIN      P156   CONT      Vel=1      m/s      CPDAT155      Tool[10]:b1      Base[14]:b1      CD;%{PE}%R
8.3.44,%MKUKATPBASIS,%CMOVE,%VLIN,%P 1:LIN, 2:P156, 3:C_DIS C_DIS, 5:1, 7:CPDAT155
$BWDSTART=FALSE
LDAT_ACT=LCPDAT155
FDAT_ACT=FP156
BAS(#CP_PARAMS,1)
TQM_FIFO_READ(TM25)
TRIGGER WHEN DISTANCE=0 DELAY=TQM_DLY() DO iTQM_TRIGGERID=25
TRIGGER WHEN DISTANCE=0 DELAY=TQM_DLY() DO TQM_START_MON(TM25) PRIO = -1
TRIGGER WHEN DISTANCE=1 DELAY=0 DO TQM_SWAP_VALUES(TM25) PRIO = -1
LIN XP156 C_DIS C_DIS
:ENDFOLD
:FOLD   LIN      P157   CONT      Vel=1      m/s      CPDAT156      Tool[10]:b1      Base[14]:b1      CD;%{PE}%R
8.3.44,%MKUKATPBASIS,%CMOVE,%VLIN,%P 1:LIN, 2:P157, 3:C_DIS C_DIS, 5:1, 7:CPDAT156
$BWDSTART=FALSE
LDAT_ACT=LCPDAT156
FDAT_ACT=FP157
BAS(#CP_PARAMS,1)
TQM_FIFO_READ(TM26)
TRIGGER WHEN DISTANCE=0 DELAY=TQM_DLY() DO iTQM_TRIGGERID=26
TRIGGER WHEN DISTANCE=0 DELAY=TQM_DLY() DO TQM_START_MON(TM26) PRIO = -1
TRIGGER WHEN DISTANCE=1 DELAY=0 DO TQM_SWAP_VALUES(TM26) PRIO = -1
LIN XP157 C_DIS C_DIS
:ENDFOLD
:FOLD   LIN      P158   CONT      Vel=1      m/s      CPDAT157      Tool[10]:b1      Base[14]:b1      CD;%{PE}%R
8.3.44,%MKUKATPBASIS,%CMOVE,%VLIN,%P 1:LIN, 2:P158, 3:C_DIS C_DIS, 5:1, 7:CPDAT157
$BWDSTART=FALSE
LDAT_ACT=LCPDAT157
FDAT_ACT=FP158
BAS(#CP_PARAMS,1)
TQM_FIFO_READ(TM27)
TRIGGER WHEN DISTANCE=0 DELAY=TQM_DLY() DO iTQM_TRIGGERID=27
TRIGGER WHEN DISTANCE=0 DELAY=TQM_DLY() DO TQM_START_MON(TM27) PRIO = -1
TRIGGER WHEN DISTANCE=1 DELAY=0 DO TQM_SWAP_VALUES(TM27) PRIO = -1
LIN XP158 C_DIS C_DIS
:ENDFOLD
:FOLD   LIN      P159   CONT      Vel=1      m/s      CPDAT158      Tool[10]:b1      Base[14]:b1      CD;%{PE}%R
8.3.44,%MKUKATPBASIS,%CMOVE,%VLIN,%P 1:LIN, 2:P159, 3:C_DIS C_DIS, 5:1, 7:CPDAT158
$BWDSTART=FALSE
LDAT_ACT=LCPDAT158
FDAT_ACT=FP159
BAS(#CP_PARAMS,1)
TQM_FIFO_READ(TM28)
TRIGGER WHEN DISTANCE=0 DELAY=TQM_DLY() DO iTQM_TRIGGERID=28
TRIGGER WHEN DISTANCE=0 DELAY=TQM_DLY() DO TQM_START_MON(TM28) PRIO = -1
TRIGGER WHEN DISTANCE=1 DELAY=0 DO TQM_SWAP_VALUES(TM28) PRIO = -1
LIN XP159 C_DIS C_DIS
:ENDFOLD
:FOLD   LIN      P160   CONT      Vel=1      m/s      CPDAT159      Tool[10]:b1      Base[14]:b1      CD;%{PE}%R
8.3.44,%MKUKATPBASIS,%CMOVE,%VLIN,%P 1:LIN, 2:P160, 3:C_DIS C_DIS, 5:1, 7:CPDAT159
$BWDSTART=FALSE
LDAT_ACT=LCPDAT159
FDAT_ACT=FP160
BAS(#CP_PARAMS,1)
TQM_FIFO_READ(TM29)
TRIGGER WHEN DISTANCE=0 DELAY=TQM_DLY() DO iTQM_TRIGGERID=29
TRIGGER WHEN DISTANCE=0 DELAY=TQM_DLY() DO TQM_START_MON(TM29) PRIO = -1
TRIGGER WHEN DISTANCE=1 DELAY=0 DO TQM_SWAP_VALUES(TM29) PRIO = -1
LIN XP160 C_DIS C_DIS
:ENDFOLD
:FOLD   LIN      P161   CONT      Vel=1      m/s      CPDAT160      Tool[10]:b1      Base[14]:b1      CD;%{PE}%R
8.3.44,%MKUKATPBASIS,%CMOVE,%VLIN,%P 1:LIN, 2:P161, 3:C_DIS C_DIS, 5:1, 7:CPDAT160
$BWDSTART=FALSE
LDAT_ACT=LCPDAT160
FDAT_ACT=FP161

```

```

BAS(#CP_PARAMS,1)
TQM_FIFO_READ(TM30)
TRIGGER WHEN DISTANCE=0 DELAY=TQM_DLY() DO iTQM_TRIGGERID=30
TRIGGER WHEN DISTANCE=0 DELAY=TQM_DLY() DO TQM_START_MON(TM30) PRIO = -1
TRIGGER WHEN DISTANCE=1 DELAY=0 DO TQM_SWAP_VALUES(TM30) PRIO = -1
LIN XP161 C_DIS C_DIS
:ENDFOLD
:FOLD LIN P162 CONT Vel=1 m/s CPDAT161 Tool[10]:b1 Base[14]:b1 CD;%{PE}%R
8.3.44,%MKUKATPBASIS,%CMOVE,%VLIN,%P 1:LIN, 2:P162, 3:C_DIS C_DIS, 5:1, 7:CPDAT161
$BWDSTART=FALSE
LDAT_ACT=LCPDAT161
FDAT_ACT=FP162
BAS(#CP_PARAMS,1)
TQM_FIFO_READ(TM31)
TRIGGER WHEN DISTANCE=0 DELAY=TQM_DLY() DO iTQM_TRIGGERID=31
TRIGGER WHEN DISTANCE=0 DELAY=TQM_DLY() DO TQM_START_MON(TM31) PRIO = -1
TRIGGER WHEN DISTANCE=1 DELAY=0 DO TQM_SWAP_VALUES(TM31) PRIO = -1
LIN XP162 C_DIS C_DIS
:ENDFOLD
:FOLD LIN P163 CONT Vel=1 m/s CPDAT162 Tool[10]:b1 Base[14]:b1 CD;%{PE}%R
8.3.44,%MKUKATPBASIS,%CMOVE,%VLIN,%P 1:LIN, 2:P163, 3:C_DIS C_DIS, 5:1, 7:CPDAT162
$BWDSTART=FALSE
LDAT_ACT=LCPDAT162
FDAT_ACT=FP163
BAS(#CP_PARAMS,1)
TQM_FIFO_READ(TM32)
TRIGGER WHEN DISTANCE=0 DELAY=TQM_DLY() DO iTQM_TRIGGERID=32
TRIGGER WHEN DISTANCE=0 DELAY=TQM_DLY() DO TQM_START_MON(TM32) PRIO = -1
TRIGGER WHEN DISTANCE=1 DELAY=0 DO TQM_SWAP_VALUES(TM32) PRIO = -1
LIN XP163 C_DIS C_DIS
:ENDFOLD
:FOLD LIN P164 CONT Vel=1 m/s CPDAT163 Tool[10]:b1 Base[14]:b1 CD;%{PE}%R
8.3.44,%MKUKATPBASIS,%CMOVE,%VLIN,%P 1:LIN, 2:P164, 3:C_DIS C_DIS, 5:1, 7:CPDAT163
$BWDSTART=FALSE
LDAT_ACT=LCPDAT163
FDAT_ACT=FP164
BAS(#CP_PARAMS,1)
TQM_FIFO_READ(TM33)
TRIGGER WHEN DISTANCE=0 DELAY=TQM_DLY() DO iTQM_TRIGGERID=33
TRIGGER WHEN DISTANCE=0 DELAY=TQM_DLY() DO TQM_START_MON(TM33) PRIO = -1
TRIGGER WHEN DISTANCE=1 DELAY=0 DO TQM_SWAP_VALUES(TM33) PRIO = -1
LIN XP164 C_DIS C_DIS
:ENDFOLD
:FOLD LIN P165 CONT Vel=1 m/s CPDAT164 Tool[10]:b1 Base[14]:b1 CD;%{PE}%R
8.3.44,%MKUKATPBASIS,%CMOVE,%VLIN,%P 1:LIN, 2:P165, 3:C_DIS C_DIS, 5:1, 7:CPDAT164
$BWDSTART=FALSE
LDAT_ACT=LCPDAT164
FDAT_ACT=FP165
BAS(#CP_PARAMS,1)
TQM_FIFO_READ(TM34)
TRIGGER WHEN DISTANCE=0 DELAY=TQM_DLY() DO iTQM_TRIGGERID=34
TRIGGER WHEN DISTANCE=0 DELAY=TQM_DLY() DO TQM_START_MON(TM34) PRIO = -1
TRIGGER WHEN DISTANCE=1 DELAY=0 DO TQM_SWAP_VALUES(TM34) PRIO = -1
LIN XP165 C_DIS C_DIS
:ENDFOLD
:FOLD LIN P166 CONT Vel=1 m/s CPDAT165 Tool[10]:b1 Base[14]:b1 CD;%{PE}%R
8.3.44,%MKUKATPBASIS,%CMOVE,%VLIN,%P 1:LIN, 2:P166, 3:C_DIS C_DIS, 5:1, 7:CPDAT165
$BWDSTART=FALSE
LDAT_ACT=LCPDAT165
FDAT_ACT=FP166
BAS(#CP_PARAMS,1)
TQM_FIFO_READ(TM35)
TRIGGER WHEN DISTANCE=0 DELAY=TQM_DLY() DO iTQM_TRIGGERID=35
TRIGGER WHEN DISTANCE=0 DELAY=TQM_DLY() DO TQM_START_MON(TM35) PRIO = -1
TRIGGER WHEN DISTANCE=1 DELAY=0 DO TQM_SWAP_VALUES(TM35) PRIO = -1
LIN XP166 C_DIS C_DIS
:ENDFOLD
:FOLD LIN P167 CONT Vel=1 m/s CPDAT166 Tool[10]:b1 Base[14]:b1 CD;%{PE}%R
8.3.44,%MKUKATPBASIS,%CMOVE,%VLIN,%P 1:LIN, 2:P167, 3:C_DIS C_DIS, 5:1, 7:CPDAT166
$BWDSTART=FALSE
LDAT_ACT=LCPDAT166
FDAT_ACT=FP167
BAS(#CP_PARAMS,1)
TQM_FIFO_READ(TM36)
TRIGGER WHEN DISTANCE=0 DELAY=TQM_DLY() DO iTQM_TRIGGERID=36

```

```

TRIGGER WHEN DISTANCE=0 DELAY=TQM_DLY() DO TQM_START_MON(TM36) PRIO = -1
TRIGGER WHEN DISTANCE=1 DELAY=0 DO TQM_SWAP_VALUES(TM36) PRIO = -1
LIN XP167 C_DIS C_DIS
;ENDFOLD
:FOLD   LIN    P169   CONT    Vel=1    m/s    CPDAT168   Tool[10]:b1   Base[14]:b1   CD;%{PE}%R
8.3.44,%MKUKATPBASIS,%CMOVE,%VLIN,%P 1:LIN, 2:P169, 3:C_DIS C_DIS, 5:1, 7:CPDAT168
$BWDSTART=FALSE
LDAT_ACT=LCPDAT168
FDAT_ACT=FP169
BAS(#CP_PARAMS,1)
TQM_FIFO_READ(TM38)
TRIGGER WHEN DISTANCE=0 DELAY=TQM_DLY() DO iTQM_TRIGGERID=38
TRIGGER WHEN DISTANCE=0 DELAY=TQM_DLY() DO TQM_START_MON(TM38) PRIO = -1
TRIGGER WHEN DISTANCE=1 DELAY=0 DO TQM_SWAP_VALUES(TM38) PRIO = -1
LIN XP169 C_DIS C_DIS
;ENDFOLD
:FOLD   LIN    P170   CONT    Vel=1    m/s    CPDAT169   Tool[10]:b1   Base[14]:b1   CD;%{PE}%R
8.3.44,%MKUKATPBASIS,%CMOVE,%VLIN,%P 1:LIN, 2:P170, 3:C_DIS C_DIS, 5:1, 7:CPDAT169
$BWDSTART=FALSE
LDAT_ACT=LCPDAT169
FDAT_ACT=FP170
BAS(#CP_PARAMS,1)
TQM_FIFO_READ(TM39)
TRIGGER WHEN DISTANCE=0 DELAY=TQM_DLY() DO iTQM_TRIGGERID=39
TRIGGER WHEN DISTANCE=0 DELAY=TQM_DLY() DO TQM_START_MON(TM39) PRIO = -1
TRIGGER WHEN DISTANCE=1 DELAY=0 DO TQM_SWAP_VALUES(TM39) PRIO = -1
LIN XP170 C_DIS C_DIS
;ENDFOLD
:FOLD   LIN    P171   CONT    Vel=1    m/s    CPDAT170   Tool[10]:b1   Base[14]:b1   CD;%{PE}%R
8.3.44,%MKUKATPBASIS,%CMOVE,%VLIN,%P 1:LIN, 2:P171, 3:C_DIS C_DIS, 5:1, 7:CPDAT170
$BWDSTART=FALSE
LDAT_ACT=LCPDAT170
FDAT_ACT=FP171
BAS(#CP_PARAMS,1)
TQM_FIFO_READ(TM40)
TRIGGER WHEN DISTANCE=0 DELAY=TQM_DLY() DO iTQM_TRIGGERID=40
TRIGGER WHEN DISTANCE=0 DELAY=TQM_DLY() DO TQM_START_MON(TM40) PRIO = -1
TRIGGER WHEN DISTANCE=1 DELAY=0 DO TQM_SWAP_VALUES(TM40) PRIO = -1
LIN XP171 C_DIS C_DIS
;ENDFOLD
:FOLD   LIN    P172   CONT    Vel=1    m/s    CPDAT171   Tool[10]:b1   Base[14]:b1   CD;%{PE}%R
8.3.44,%MKUKATPBASIS,%CMOVE,%VLIN,%P 1:LIN, 2:P172, 3:C_DIS C_DIS, 5:1, 7:CPDAT171
$BWDSTART=FALSE
LDAT_ACT=LCPDAT171
FDAT_ACT=FP172
BAS(#CP_PARAMS,1)
TQM_FIFO_READ(TM41)
TRIGGER WHEN DISTANCE=0 DELAY=TQM_DLY() DO iTQM_TRIGGERID=41
TRIGGER WHEN DISTANCE=0 DELAY=TQM_DLY() DO TQM_START_MON(TM41) PRIO = -1
TRIGGER WHEN DISTANCE=1 DELAY=0 DO TQM_SWAP_VALUES(TM41) PRIO = -1
LIN XP172 C_DIS C_DIS
;ENDFOLD
:FOLD   LIN    P173   CONT    Vel=1    m/s    CPDAT172   Tool[10]:b1   Base[14]:b1   CD;%{PE}%R
8.3.44,%MKUKATPBASIS,%CMOVE,%VLIN,%P 1:LIN, 2:P173, 3:C_DIS C_DIS, 5:1, 7:CPDAT172
$BWDSTART=FALSE
LDAT_ACT=LCPDAT172
FDAT_ACT=FP173
BAS(#CP_PARAMS,1)
TQM_FIFO_READ(TM42)
TRIGGER WHEN DISTANCE=0 DELAY=TQM_DLY() DO iTQM_TRIGGERID=42
TRIGGER WHEN DISTANCE=0 DELAY=TQM_DLY() DO TQM_START_MON(TM42) PRIO = -1
TRIGGER WHEN DISTANCE=1 DELAY=0 DO TQM_SWAP_VALUES(TM42) PRIO = -1
LIN XP173 C_DIS C_DIS
;ENDFOLD
:FOLD   LIN    P174   CONT    Vel=1    m/s    CPDAT173   Tool[10]:b1   Base[14]:b1   CD;%{PE}%R
8.3.44,%MKUKATPBASIS,%CMOVE,%VLIN,%P 1:LIN, 2:P174, 3:C_DIS C_DIS, 5:1, 7:CPDAT173
$BWDSTART=FALSE
LDAT_ACT=LCPDAT173
FDAT_ACT=FP174
BAS(#CP_PARAMS,1)
TQM_FIFO_READ(TM43)
TRIGGER WHEN DISTANCE=0 DELAY=TQM_DLY() DO iTQM_TRIGGERID=43
TRIGGER WHEN DISTANCE=0 DELAY=TQM_DLY() DO TQM_START_MON(TM43) PRIO = -1
TRIGGER WHEN DISTANCE=1 DELAY=0 DO TQM_SWAP_VALUES(TM43) PRIO = -1
LIN XP174 C_DIS C_DIS

```

```

:ENDFOLD
:FOLD   LIN      P175   CONT   Vel=1   m/s   CPDAT174   Tool[10]:b1   Base[14]:b1   CD;{%PE}%R
8.3.44,%MKUKATPBASIS,%CMOVE,%VLIN,%P 1:LIN, 2:P175, 3:C_DIS C_DIS, 5:1, 7:CPDAT174
$BWDSTART=FALSE
LDAT_ACT=LCPDAT174
FDAT_ACT=FP175
BAS(#CP_PARAMS,1)
TQM_FIFO_READ(TM44)
TRIGGER WHEN DISTANCE=0 DELAY=TQM_DLY() DO iTQM_TRIGGERID=44
TRIGGER WHEN DISTANCE=0 DELAY=TQM_DLY() DO TQM_START_MON(TM44) PRIO = -1
TRIGGER WHEN DISTANCE=1 DELAY=0 DO TQM_SWAP_VALUES(TM44) PRIO = -1
LIN XP175 C_DIS C_DIS
:ENDFOLD
:FOLD   LIN      P176   CONT   Vel=1   m/s   CPDAT175   Tool[10]:b1   Base[14]:b1   CD;{%PE}%R
8.3.44,%MKUKATPBASIS,%CMOVE,%VLIN,%P 1:LIN, 2:P176, 3:C_DIS C_DIS, 5:1, 7:CPDAT175
$BWDSTART=FALSE
LDAT_ACT=LCPDAT175
FDAT_ACT=FP176
BAS(#CP_PARAMS,1)
TQM_FIFO_READ(TM45)
TRIGGER WHEN DISTANCE=0 DELAY=TQM_DLY() DO iTQM_TRIGGERID=45
TRIGGER WHEN DISTANCE=0 DELAY=TQM_DLY() DO TQM_START_MON(TM45) PRIO = -1
TRIGGER WHEN DISTANCE=1 DELAY=0 DO TQM_SWAP_VALUES(TM45) PRIO = -1
LIN XP176 C_DIS C_DIS
:ENDFOLD
:FOLD   LIN      P177   CONT   Vel=1   m/s   CPDAT176   Tool[10]:b1   Base[14]:b1   CD;{%PE}%R
8.3.44,%MKUKATPBASIS,%CMOVE,%VLIN,%P 1:LIN, 2:P177, 3:C_DIS C_DIS, 5:1, 7:CPDAT176
$BWDSTART=FALSE
LDAT_ACT=LCPDAT176
FDAT_ACT=FP177
BAS(#CP_PARAMS,1)
TQM_FIFO_READ(TM46)
TRIGGER WHEN DISTANCE=0 DELAY=TQM_DLY() DO iTQM_TRIGGERID=46
TRIGGER WHEN DISTANCE=0 DELAY=TQM_DLY() DO TQM_START_MON(TM46) PRIO = -1
TRIGGER WHEN DISTANCE=1 DELAY=0 DO TQM_SWAP_VALUES(TM46) PRIO = -1
LIN XP177 C_DIS C_DIS
:ENDFOLD
:FOLD   LIN      P178   CONT   Vel=1   m/s   CPDAT177   Tool[10]:b1   Base[14]:b1   CD;{%PE}%R
8.3.44,%MKUKATPBASIS,%CMOVE,%VLIN,%P 1:LIN, 2:P178, 3:C_DIS C_DIS, 5:1, 7:CPDAT177
$BWDSTART=FALSE
LDAT_ACT=LCPDAT177
FDAT_ACT=FP178
BAS(#CP_PARAMS,1)
TQM_FIFO_READ(TM47)
TRIGGER WHEN DISTANCE=0 DELAY=TQM_DLY() DO iTQM_TRIGGERID=47
TRIGGER WHEN DISTANCE=0 DELAY=TQM_DLY() DO TQM_START_MON(TM47) PRIO = -1
TRIGGER WHEN DISTANCE=1 DELAY=0 DO TQM_SWAP_VALUES(TM47) PRIO = -1
LIN XP178 C_DIS C_DIS
:ENDFOLD
:FOLD   LIN      P179   CONT   Vel=1   m/s   CPDAT178   Tool[10]:b1   Base[14]:b1   CD;{%PE}%R
8.3.44,%MKUKATPBASIS,%CMOVE,%VLIN,%P 1:LIN, 2:P179, 3:C_DIS C_DIS, 5:1, 7:CPDAT178
$BWDSTART=FALSE
LDAT_ACT=LCPDAT178
FDAT_ACT=FP179
BAS(#CP_PARAMS,1)
TQM_FIFO_READ(TM48)
TRIGGER WHEN DISTANCE=0 DELAY=TQM_DLY() DO iTQM_TRIGGERID=48
TRIGGER WHEN DISTANCE=0 DELAY=TQM_DLY() DO TQM_START_MON(TM48) PRIO = -1
TRIGGER WHEN DISTANCE=1 DELAY=0 DO TQM_SWAP_VALUES(TM48) PRIO = -1
LIN XP179 C_DIS C_DIS
:ENDFOLD
:FOLD   LIN      P183   CONT   Vel=1   m/s   CPDAT182   Tool[10]:b1   Base[14]:b1   CD;{%PE}%R
8.3.44,%MKUKATPBASIS,%CMOVE,%VLIN,%P 1:LIN, 2:P183, 3:C_DIS C_DIS, 5:1, 7:CPDAT182
$BWDSTART=FALSE
LDAT_ACT=LCPDAT182
FDAT_ACT=FP183
BAS(#CP_PARAMS,1)
TQM_FIFO_READ(TM52)
TRIGGER WHEN DISTANCE=0 DELAY=TQM_DLY() DO iTQM_TRIGGERID=52
TRIGGER WHEN DISTANCE=0 DELAY=TQM_DLY() DO TQM_START_MON(TM52) PRIO = -1
TRIGGER WHEN DISTANCE=1 DELAY=0 DO TQM_SWAP_VALUES(TM52) PRIO = -1
LIN XP183 C_DIS C_DIS
:ENDFOLD
:FOLD   LIN      P184   CONT   Vel=1   m/s   CPDAT183   Tool[10]:b1   Base[14]:b1   CD;{%PE}%R
8.3.44,%MKUKATPBASIS,%CMOVE,%VLIN,%P 1:LIN, 2:P184, 3:C_DIS C_DIS, 5:1, 7:CPDAT183

```

```

$BWDSTART=FALSE
LDAT_ACT=LCPDAT183
FDAT_ACT=FP184
BAS(#CP_PARAMS,1)
TQM_FIFO_READ(TM53)
TRIGGER WHEN DISTANCE=0 DELAY=TQM_DLY() DO iTQM_TRIGGERID=53
TRIGGER WHEN DISTANCE=0 DELAY=TQM_DLY() DO TQM_START_MON(TM53) PRIO = -1
TRIGGER WHEN DISTANCE=1 DELAY=0 DO TQM_SWAP_VALUES(TM53) PRIO = -1
LIN XP184 C_DIS C_DIS
:ENDFOLD
:FOLD  LIN      P185  CONT      Vel=1      m/s      CPDAT184      Tool[10]:b1      Base[14]:b1      CD;%{PE}%R
8.3.44,%MKUKATPBASIS,%CMOVE,%VLIN,%P 1:LIN, 2:P185, 3:C_DIS C_DIS, 5:1, 7:CPDAT184
$BWDSTART=FALSE
LDAT_ACT=LCPDAT184
FDAT_ACT=FP185
BAS(#CP_PARAMS,1)
TQM_FIFO_READ(TM54)
TRIGGER WHEN DISTANCE=0 DELAY=TQM_DLY() DO iTQM_TRIGGERID=54
TRIGGER WHEN DISTANCE=0 DELAY=TQM_DLY() DO TQM_START_MON(TM54) PRIO = -1
TRIGGER WHEN DISTANCE=1 DELAY=0 DO TQM_SWAP_VALUES(TM54) PRIO = -1
LIN XP185 C_DIS C_DIS
:ENDFOLD
:FOLD  LIN      P186  CONT      Vel=1      m/s      CPDAT185      Tool[10]:b1      Base[14]:b1      CD;%{PE}%R
8.3.44,%MKUKATPBASIS,%CMOVE,%VLIN,%P 1:LIN, 2:P186, 3:C_DIS C_DIS, 5:1, 7:CPDAT185
$BWDSTART=FALSE
LDAT_ACT=LCPDAT185
FDAT_ACT=FP186
BAS(#CP_PARAMS,1)
TQM_FIFO_READ(TM55)
TRIGGER WHEN DISTANCE=0 DELAY=TQM_DLY() DO iTQM_TRIGGERID=55
TRIGGER WHEN DISTANCE=0 DELAY=TQM_DLY() DO TQM_START_MON(TM55) PRIO = -1
TRIGGER WHEN DISTANCE=1 DELAY=0 DO TQM_SWAP_VALUES(TM55) PRIO = -1
LIN XP186 C_DIS C_DIS
:ENDFOLD
:FOLD  LIN      P188  CONT      Vel=1      m/s      CPDAT187      Tool[10]:b1      Base[14]:b1      CD;%{PE}%R
8.3.44,%MKUKATPBASIS,%CMOVE,%VLIN,%P 1:LIN, 2:P188, 3:C_DIS C_DIS, 5:1, 7:CPDAT187
$BWDSTART=FALSE
LDAT_ACT=LCPDAT187
FDAT_ACT=FP188
BAS(#CP_PARAMS,1)
TQM_FIFO_READ(TM57)
TRIGGER WHEN DISTANCE=0 DELAY=TQM_DLY() DO iTQM_TRIGGERID=57
TRIGGER WHEN DISTANCE=0 DELAY=TQM_DLY() DO TQM_START_MON(TM57) PRIO = -1
TRIGGER WHEN DISTANCE=1 DELAY=0 DO TQM_SWAP_VALUES(TM57) PRIO = -1
LIN XP188 C_DIS C_DIS
:ENDFOLD
:FOLD  LIN      P190  CONT      Vel=1      m/s      CPDAT189      Tool[10]:b1      Base[14]:b1      CD;%{PE}%R
8.3.44,%MKUKATPBASIS,%CMOVE,%VLIN,%P 1:LIN, 2:P190, 3:C_DIS C_DIS, 5:1, 7:CPDAT189
$BWDSTART=FALSE
LDAT_ACT=LCPDAT189
FDAT_ACT=FP190
BAS(#CP_PARAMS,1)
TQM_FIFO_READ(TM59)
TRIGGER WHEN DISTANCE=0 DELAY=TQM_DLY() DO iTQM_TRIGGERID=59
TRIGGER WHEN DISTANCE=0 DELAY=TQM_DLY() DO TQM_START_MON(TM59) PRIO = -1
TRIGGER WHEN DISTANCE=1 DELAY=0 DO TQM_SWAP_VALUES(TM59) PRIO = -1
LIN XP190 C_DIS C_DIS
:ENDFOLD
:FOLD  LIN      P192  CONT      Vel=1      m/s      CPDAT191      Tool[10]:b1      Base[14]:b1      CD;%{PE}%R
8.3.44,%MKUKATPBASIS,%CMOVE,%VLIN,%P 1:LIN, 2:P192, 3:C_DIS C_DIS, 5:1, 7:CPDAT191
$BWDSTART=FALSE
LDAT_ACT=LCPDAT191
FDAT_ACT=FP192
BAS(#CP_PARAMS,1)
TQM_FIFO_READ(TM61)
TRIGGER WHEN DISTANCE=0 DELAY=TQM_DLY() DO iTQM_TRIGGERID=61
TRIGGER WHEN DISTANCE=0 DELAY=TQM_DLY() DO TQM_START_MON(TM61) PRIO = -1
TRIGGER WHEN DISTANCE=1 DELAY=0 DO TQM_SWAP_VALUES(TM61) PRIO = -1
LIN XP192 C_DIS C_DIS
:ENDFOLD
:FOLD  LIN      P194  CONT      Vel=1      m/s      CPDAT193      Tool[10]:b1      Base[14]:b1      CD;%{PE}%R
8.3.44,%MKUKATPBASIS,%CMOVE,%VLIN,%P 1:LIN, 2:P194, 3:C_DIS C_DIS, 5:1, 7:CPDAT193
$BWDSTART=FALSE
LDAT_ACT=LCPDAT193
FDAT_ACT=FP194

```

```

BAS(#CP_PARAMS,1)
TQM_FIFO_READ(TM63)
TRIGGER WHEN DISTANCE=0 DELAY=TQM_DLY() DO iTQM_TRIGGERID=63
TRIGGER WHEN DISTANCE=0 DELAY=TQM_DLY() DO TQM_START_MON(TM63) PRIO = -1
TRIGGER WHEN DISTANCE=1 DELAY=0 DO TQM_SWAP_VALUES(TM63) PRIO = -1
LIN XP194 C_DIS C_DIS
:ENDFOLD
:FOLD LIN P195 CONT Vel=1 m/s CPDAT194 Tool[10]:b1 Base[14]:b1 CD;%{PE}%R
8.3.44,%MKUKATPBASIS,%CMOVE,%VLIN,%P 1:LIN, 2:P195, 3:C_DIS C_DIS, 5:1, 7:CPDAT194
$BWDSTART=FALSE
LDAT_ACT=LCPDAT194
FDAT_ACT=FP195
BAS(#CP_PARAMS,1)
TQM_FIFO_READ(TM64)
TRIGGER WHEN DISTANCE=0 DELAY=TQM_DLY() DO iTQM_TRIGGERID=64
TRIGGER WHEN DISTANCE=0 DELAY=TQM_DLY() DO TQM_START_MON(TM64) PRIO = -1
TRIGGER WHEN DISTANCE=1 DELAY=0 DO TQM_SWAP_VALUES(TM64) PRIO = -1
LIN XP195 C_DIS C_DIS
:ENDFOLD
:FOLD LIN P198 CONT Vel=1 m/s CPDAT197 Tool[10]:b1 Base[14]:b1 CD;%{PE}%R
8.3.44,%MKUKATPBASIS,%CMOVE,%VLIN,%P 1:LIN, 2:P198, 3:C_DIS C_DIS, 5:1, 7:CPDAT197
$BWDSTART=FALSE
LDAT_ACT=LCPDAT197
FDAT_ACT=FP198
BAS(#CP_PARAMS,1)
TQM_FIFO_READ(TM67)
TRIGGER WHEN DISTANCE=0 DELAY=TQM_DLY() DO iTQM_TRIGGERID=67
TRIGGER WHEN DISTANCE=0 DELAY=TQM_DLY() DO TQM_START_MON(TM67) PRIO = -1
TRIGGER WHEN DISTANCE=1 DELAY=0 DO TQM_SWAP_VALUES(TM67) PRIO = -1
LIN XP198 C_DIS C_DIS
:ENDFOLD
:FOLD LIN P199 CONT Vel=1 m/s CPDAT198 Tool[10]:b1 Base[14]:b1 CD;%{PE}%R
8.3.44,%MKUKATPBASIS,%CMOVE,%VLIN,%P 1:LIN, 2:P199, 3:C_DIS C_DIS, 5:1, 7:CPDAT198
$BWDSTART=FALSE
LDAT_ACT=LCPDAT198
FDAT_ACT=FP199
BAS(#CP_PARAMS,1)
TQM_FIFO_READ(TM68)
TRIGGER WHEN DISTANCE=0 DELAY=TQM_DLY() DO iTQM_TRIGGERID=68
TRIGGER WHEN DISTANCE=0 DELAY=TQM_DLY() DO TQM_START_MON(TM68) PRIO = -1
TRIGGER WHEN DISTANCE=1 DELAY=0 DO TQM_SWAP_VALUES(TM68) PRIO = -1
LIN XP199 C_DIS C_DIS
:ENDFOLD
:FOLD LIN P200 CONT Vel=1 m/s CPDAT199 Tool[10]:b1 Base[14]:b1 CD;%{PE}%R
8.3.44,%MKUKATPBASIS,%CMOVE,%VLIN,%P 1:LIN, 2:P200, 3:C_DIS C_DIS, 5:1, 7:CPDAT199
$BWDSTART=FALSE
LDAT_ACT=LCPDAT199
FDAT_ACT=FP200
BAS(#CP_PARAMS,1)
TQM_FIFO_READ(TM69)
TRIGGER WHEN DISTANCE=0 DELAY=TQM_DLY() DO iTQM_TRIGGERID=69
TRIGGER WHEN DISTANCE=0 DELAY=TQM_DLY() DO TQM_START_MON(TM69) PRIO = -1
TRIGGER WHEN DISTANCE=1 DELAY=0 DO TQM_SWAP_VALUES(TM69) PRIO = -1
LIN XP200 C_DIS C_DIS
:ENDFOLD
:FOLD LIN P201 CONT Vel=1 m/s CPDAT200 Tool[10]:b1 Base[14]:b1 CD;%{PE}%R
8.3.44,%MKUKATPBASIS,%CMOVE,%VLIN,%P 1:LIN, 2:P201, 3:C_DIS C_DIS, 5:1, 7:CPDAT200
$BWDSTART=FALSE
LDAT_ACT=LCPDAT200
FDAT_ACT=FP201
BAS(#CP_PARAMS,1)
TQM_FIFO_READ(TM70)
TRIGGER WHEN DISTANCE=0 DELAY=TQM_DLY() DO iTQM_TRIGGERID=70
TRIGGER WHEN DISTANCE=0 DELAY=TQM_DLY() DO TQM_START_MON(TM70) PRIO = -1
TRIGGER WHEN DISTANCE=1 DELAY=0 DO TQM_SWAP_VALUES(TM70) PRIO = -1
LIN XP201 C_DIS C_DIS
:ENDFOLD
:FOLD LIN P202 CONT Vel=1 m/s CPDAT201 Tool[10]:b1 Base[14]:b1 CD;%{PE}%R
8.3.44,%MKUKATPBASIS,%CMOVE,%VLIN,%P 1:LIN, 2:P202, 3:C_DIS C_DIS, 5:1, 7:CPDAT201
$BWDSTART=FALSE
LDAT_ACT=LCPDAT201
FDAT_ACT=FP202
BAS(#CP_PARAMS,1)
TQM_FIFO_READ(TM71)
TRIGGER WHEN DISTANCE=0 DELAY=TQM_DLY() DO iTQM_TRIGGERID=71

```

```

TRIGGER WHEN DISTANCE=0 DELAY=TQM_DLY() DO TQM_START_MON(TM71) PRIO = -1
TRIGGER WHEN DISTANCE=1 DELAY=0 DO TQM_SWAP_VALUES(TM71) PRIO = -1
LIN XP202 C_DIS C_DIS
;ENDFOLD
:FOLD   LIN      P204   CONT   Vel=1   m/s   CPDAT203   Tool[10]:b1   Base[14]:b1   CD;%{PE}%R
8.3.44,%MKUKATPBASIS,%CMOVE,%VLIN,%P 1:LIN, 2:P204, 3:C_DIS C_DIS, 5:1, 7:CPDAT203
$BWDSTART=FALSE
LDAT_ACT=LCPDAT203
FDAT_ACT=FP204
BAS(#CP_PARAMS,1)
TQM_FIFO_READ(TM73)
TRIGGER WHEN DISTANCE=0 DELAY=TQM_DLY() DO iTQM_TRIGGERID=73
TRIGGER WHEN DISTANCE=0 DELAY=TQM_DLY() DO TQM_START_MON(TM73) PRIO = -1
TRIGGER WHEN DISTANCE=1 DELAY=0 DO TQM_SWAP_VALUES(TM73) PRIO = -1
LIN XP204 C_DIS C_DIS
;ENDFOLD
:FOLD   LIN      P205   CONT   Vel=1   m/s   CPDAT204   Tool[10]:b1   Base[14]:b1   CD;%{PE}%R
8.3.44,%MKUKATPBASIS,%CMOVE,%VLIN,%P 1:LIN, 2:P205, 3:C_DIS C_DIS, 5:1, 7:CPDAT204
$BWDSTART=FALSE
LDAT_ACT=LCPDAT204
FDAT_ACT=FP205
BAS(#CP_PARAMS,1)
TQM_FIFO_READ(TM74)
TRIGGER WHEN DISTANCE=0 DELAY=TQM_DLY() DO iTQM_TRIGGERID=74
TRIGGER WHEN DISTANCE=0 DELAY=TQM_DLY() DO TQM_START_MON(TM74) PRIO = -1
TRIGGER WHEN DISTANCE=1 DELAY=0 DO TQM_SWAP_VALUES(TM74) PRIO = -1
LIN XP205 C_DIS C_DIS
;ENDFOLD
:FOLD   LIN      P206   CONT   Vel=1   m/s   CPDAT205   Tool[10]:b1   Base[14]:b1   CD;%{PE}%R
8.3.44,%MKUKATPBASIS,%CMOVE,%VLIN,%P 1:LIN, 2:P206, 3:C_DIS C_DIS, 5:1, 7:CPDAT205
$BWDSTART=FALSE
LDAT_ACT=LCPDAT205
FDAT_ACT=FP206
BAS(#CP_PARAMS,1)
TQM_FIFO_READ(TM75)
TRIGGER WHEN DISTANCE=0 DELAY=TQM_DLY() DO iTQM_TRIGGERID=75
TRIGGER WHEN DISTANCE=0 DELAY=TQM_DLY() DO TQM_START_MON(TM75) PRIO = -1
TRIGGER WHEN DISTANCE=1 DELAY=0 DO TQM_SWAP_VALUES(TM75) PRIO = -1
LIN XP206 C_DIS C_DIS
;ENDFOLD
:FOLD   LIN      P207   CONT   Vel=1   m/s   CPDAT206   Tool[10]:b1   Base[14]:b1   CD;%{PE}%R
8.3.44,%MKUKATPBASIS,%CMOVE,%VLIN,%P 1:LIN, 2:P207, 3:C_DIS C_DIS, 5:1, 7:CPDAT206
$BWDSTART=FALSE
LDAT_ACT=LCPDAT206
FDAT_ACT=FP207
BAS(#CP_PARAMS,1)
TQM_FIFO_READ(TM76)
TRIGGER WHEN DISTANCE=0 DELAY=TQM_DLY() DO iTQM_TRIGGERID=76
TRIGGER WHEN DISTANCE=0 DELAY=TQM_DLY() DO TQM_START_MON(TM76) PRIO = -1
TRIGGER WHEN DISTANCE=1 DELAY=0 DO TQM_SWAP_VALUES(TM76) PRIO = -1
LIN XP207 C_DIS C_DIS
;ENDFOLD
:FOLD   LIN      P208   CONT   Vel=1   m/s   CPDAT207   Tool[10]:b1   Base[14]:b1   CD;%{PE}%R
8.3.44,%MKUKATPBASIS,%CMOVE,%VLIN,%P 1:LIN, 2:P208, 3:C_DIS C_DIS, 5:1, 7:CPDAT207
$BWDSTART=FALSE
LDAT_ACT=LCPDAT207
FDAT_ACT=FP208
BAS(#CP_PARAMS,1)
TQM_FIFO_READ(TM77)
TRIGGER WHEN DISTANCE=0 DELAY=TQM_DLY() DO iTQM_TRIGGERID=77
TRIGGER WHEN DISTANCE=0 DELAY=TQM_DLY() DO TQM_START_MON(TM77) PRIO = -1
TRIGGER WHEN DISTANCE=1 DELAY=0 DO TQM_SWAP_VALUES(TM77) PRIO = -1
LIN XP208 C_DIS C_DIS
;ENDFOLD
:FOLD   LIN      P209   CONT   Vel=1   m/s   CPDAT208   Tool[10]:b1   Base[14]:b1   CD;%{PE}%R
8.3.44,%MKUKATPBASIS,%CMOVE,%VLIN,%P 1:LIN, 2:P209, 3:C_DIS C_DIS, 5:1, 7:CPDAT208
$BWDSTART=FALSE
LDAT_ACT=LCPDAT208
FDAT_ACT=FP209
BAS(#CP_PARAMS,1)
TQM_FIFO_READ(TM78)
TRIGGER WHEN DISTANCE=0 DELAY=TQM_DLY() DO iTQM_TRIGGERID=78
TRIGGER WHEN DISTANCE=0 DELAY=TQM_DLY() DO TQM_START_MON(TM78) PRIO = -1
TRIGGER WHEN DISTANCE=1 DELAY=0 DO TQM_SWAP_VALUES(TM78) PRIO = -1
LIN XP209 C_DIS C_DIS

```



```

:ENDFOLD
:FOLD   LIN      P210   CONT   Vel=1   m/s   CPDAT209   Tool[10]:b1   Base[14]:b1   CD;%{PE}%R
8.3.44,%MKUKATPBASIS,%CMOVE,%VLIN,%P 1:LIN, 2:P210, 3:C_DIS C_DIS, 5:1, 7:CPDAT209
$BWDSTART=FALSE
LDAT_ACT=LCPDAT209
FDAT_ACT=FP210
BAS(#CP_PARAMS,1)
TQM_FIFO_READ(TM79)
TRIGGER WHEN DISTANCE=0 DELAY=TQM_DLY() DO iTQM_TRIGGERID=79
TRIGGER WHEN DISTANCE=0 DELAY=TQM_DLY() DO TQM_START_MON(TM79) PRIO = -1
TRIGGER WHEN DISTANCE=1 DELAY=0 DO TQM_SWAP_VALUES(TM79) PRIO = -1
LIN XP210 C_DIS C_DIS
:ENDFOLD
:FOLD   LIN      P212   CONT   Vel=1   m/s   CPDAT211   Tool[10]:b1   Base[14]:b1   CD;%{PE}%R
8.3.44,%MKUKATPBASIS,%CMOVE,%VLIN,%P 1:LIN, 2:P212, 3:C_DIS C_DIS, 5:1, 7:CPDAT211
$BWDSTART=FALSE
LDAT_ACT=LCPDAT211
FDAT_ACT=FP212
BAS(#CP_PARAMS,1)
TQM_FIFO_READ(TM81)
TRIGGER WHEN DISTANCE=0 DELAY=TQM_DLY() DO iTQM_TRIGGERID=81
TRIGGER WHEN DISTANCE=0 DELAY=TQM_DLY() DO TQM_START_MON(TM81) PRIO = -1
TRIGGER WHEN DISTANCE=1 DELAY=0 DO TQM_SWAP_VALUES(TM81) PRIO = -1
LIN XP212 C_DIS C_DIS
:ENDFOLD
:FOLD   LIN      P213   CONT   Vel=1   m/s   CPDAT212   Tool[10]:b1   Base[14]:b1   CD;%{PE}%R
8.3.44,%MKUKATPBASIS,%CMOVE,%VLIN,%P 1:LIN, 2:P213, 3:C_DIS C_DIS, 5:1, 7:CPDAT212
$BWDSTART=FALSE
LDAT_ACT=LCPDAT212
FDAT_ACT=FP213
BAS(#CP_PARAMS,1)
TQM_FIFO_READ(TM82)
TRIGGER WHEN DISTANCE=0 DELAY=TQM_DLY() DO iTQM_TRIGGERID=82
TRIGGER WHEN DISTANCE=0 DELAY=TQM_DLY() DO TQM_START_MON(TM82) PRIO = -1
TRIGGER WHEN DISTANCE=1 DELAY=0 DO TQM_SWAP_VALUES(TM82) PRIO = -1
LIN XP213 C_DIS C_DIS
:ENDFOLD
:FOLD   LIN      P214   CONT   Vel=1   m/s   CPDAT213   Tool[10]:b1   Base[14]:b1   CD;%{PE}%R
8.3.44,%MKUKATPBASIS,%CMOVE,%VLIN,%P 1:LIN, 2:P214, 3:C_DIS C_DIS, 5:1, 7:CPDAT213
$BWDSTART=FALSE
LDAT_ACT=LCPDAT213
FDAT_ACT=FP214
BAS(#CP_PARAMS,1)
TQM_FIFO_READ(TM83)
TRIGGER WHEN DISTANCE=0 DELAY=TQM_DLY() DO iTQM_TRIGGERID=83
TRIGGER WHEN DISTANCE=0 DELAY=TQM_DLY() DO TQM_START_MON(TM83) PRIO = -1
TRIGGER WHEN DISTANCE=1 DELAY=0 DO TQM_SWAP_VALUES(TM83) PRIO = -1
LIN XP214 C_DIS C_DIS
:ENDFOLD
:FOLD   LIN      P215   CONT   Vel=1   m/s   CPDAT214   Tool[10]:b1   Base[14]:b1   CD;%{PE}%R
8.3.44,%MKUKATPBASIS,%CMOVE,%VLIN,%P 1:LIN, 2:P215, 3:C_DIS C_DIS, 5:1, 7:CPDAT214
$BWDSTART=FALSE
LDAT_ACT=LCPDAT214
FDAT_ACT=FP215
BAS(#CP_PARAMS,1)
TQM_FIFO_READ(TM84)
TRIGGER WHEN DISTANCE=0 DELAY=TQM_DLY() DO iTQM_TRIGGERID=84
TRIGGER WHEN DISTANCE=0 DELAY=TQM_DLY() DO TQM_START_MON(TM84) PRIO = -1
TRIGGER WHEN DISTANCE=1 DELAY=0 DO TQM_SWAP_VALUES(TM84) PRIO = -1
LIN XP215 C_DIS C_DIS
:ENDFOLD
:FOLD   LIN      P216   CONT   Vel=1   m/s   CPDAT215   Tool[10]:b1   Base[14]:b1   CD;%{PE}%R
8.3.44,%MKUKATPBASIS,%CMOVE,%VLIN,%P 1:LIN, 2:P216, 3:C_DIS C_DIS, 5:1, 7:CPDAT215
$BWDSTART=FALSE
LDAT_ACT=LCPDAT215
FDAT_ACT=FP216
BAS(#CP_PARAMS,1)
TQM_FIFO_READ(TM85)
TRIGGER WHEN DISTANCE=0 DELAY=TQM_DLY() DO iTQM_TRIGGERID=85
TRIGGER WHEN DISTANCE=0 DELAY=TQM_DLY() DO TQM_START_MON(TM85) PRIO = -1
TRIGGER WHEN DISTANCE=1 DELAY=0 DO TQM_SWAP_VALUES(TM85) PRIO = -1
LIN XP216 C_DIS C_DIS
:ENDFOLD
:FOLD   LIN      P217   CONT   Vel=1   m/s   CPDAT216   Tool[10]:b1   Base[14]:b1   CD;%{PE}%R
8.3.44,%MKUKATPBASIS,%CMOVE,%VLIN,%P 1:LIN, 2:P217, 3:C_DIS C_DIS, 5:1, 7:CPDAT216

```

```

$BWDSTART=FALSE
LDAT_ACT=LCPDAT216
FDAT_ACT=FP217
BAS(#CP_PARAMS,1)
TQM_FIFO_READ(TM86)
TRIGGER WHEN DISTANCE=0 DELAY=TQM_DLY() DO iTQM_TRIGGERID=86
TRIGGER WHEN DISTANCE=0 DELAY=TQM_DLY() DO TQM_START_MON(TM86) PRIO = -1
TRIGGER WHEN DISTANCE=1 DELAY=0 DO TQM_SWAP_VALUES(TM86) PRIO = -1
LIN XP217 C_DIS C_DIS
:ENDFOLD
:FOLD   LIN      P218   CONT   Vel=1   m/s   CPDAT217   Tool[10]:b1   Base[14]:b1   CD;%{PE}%R
8.3.44,%MKUKATPBASIS,%CMOVE,%VLIN,%P 1:LIN, 2:P218, 3:C_DIS C_DIS, 5:1, 7:CPDAT217
$BWDSTART=FALSE
LDAT_ACT=LCPDAT217
FDAT_ACT=FP218
BAS(#CP_PARAMS,1)
TQM_FIFO_READ(TM87)
TRIGGER WHEN DISTANCE=0 DELAY=TQM_DLY() DO iTQM_TRIGGERID=87
TRIGGER WHEN DISTANCE=0 DELAY=TQM_DLY() DO TQM_START_MON(TM87) PRIO = -1
TRIGGER WHEN DISTANCE=1 DELAY=0 DO TQM_SWAP_VALUES(TM87) PRIO = -1
LIN XP218 C_DIS C_DIS
:ENDFOLD
:FOLD   LIN      P219   CONT   Vel=1   m/s   CPDAT218   Tool[10]:b1   Base[14]:b1   CD;%{PE}%R
8.3.44,%MKUKATPBASIS,%CMOVE,%VLIN,%P 1:LIN, 2:P219, 3:C_DIS C_DIS, 5:1, 7:CPDAT218
$BWDSTART=FALSE
LDAT_ACT=LCPDAT218
FDAT_ACT=FP219
BAS(#CP_PARAMS,1)
TQM_FIFO_READ(TM88)
TRIGGER WHEN DISTANCE=0 DELAY=TQM_DLY() DO iTQM_TRIGGERID=88
TRIGGER WHEN DISTANCE=0 DELAY=TQM_DLY() DO TQM_START_MON(TM88) PRIO = -1
TRIGGER WHEN DISTANCE=1 DELAY=0 DO TQM_SWAP_VALUES(TM88) PRIO = -1
LIN XP219 C_DIS C_DIS
:ENDFOLD
:FOLD   LIN      P220   CONT   Vel=1   m/s   CPDAT219   Tool[10]:b1   Base[14]:b1   CD;%{PE}%R
8.3.44,%MKUKATPBASIS,%CMOVE,%VLIN,%P 1:LIN, 2:P220, 3:C_DIS C_DIS, 5:1, 7:CPDAT219
$BWDSTART=FALSE
LDAT_ACT=LCPDAT219
FDAT_ACT=FP220
BAS(#CP_PARAMS,1)
TQM_FIFO_READ(TM89)
TRIGGER WHEN DISTANCE=0 DELAY=TQM_DLY() DO iTQM_TRIGGERID=89
TRIGGER WHEN DISTANCE=0 DELAY=TQM_DLY() DO TQM_START_MON(TM89) PRIO = -1
TRIGGER WHEN DISTANCE=1 DELAY=0 DO TQM_SWAP_VALUES(TM89) PRIO = -1
LIN XP220 C_DIS C_DIS
:ENDFOLD
:FOLD   LIN      P221   CONT   Vel=1   m/s   CPDAT220   Tool[10]:b1   Base[14]:b1   CD;%{PE}%R
8.3.44,%MKUKATPBASIS,%CMOVE,%VLIN,%P 1:LIN, 2:P221, 3:C_DIS C_DIS, 5:1, 7:CPDAT220
$BWDSTART=FALSE
LDAT_ACT=LCPDAT220
FDAT_ACT=FP221
BAS(#CP_PARAMS,1)
TQM_FIFO_READ(TM90)
TRIGGER WHEN DISTANCE=0 DELAY=TQM_DLY() DO iTQM_TRIGGERID=90
TRIGGER WHEN DISTANCE=0 DELAY=TQM_DLY() DO TQM_START_MON(TM90) PRIO = -1
TRIGGER WHEN DISTANCE=1 DELAY=0 DO TQM_SWAP_VALUES(TM90) PRIO = -1
LIN XP221 C_DIS C_DIS
:ENDFOLD
:FOLD   LIN      P222   CONT   Vel=1   m/s   CPDAT221   Tool[10]:b1   Base[14]:b1   CD;%{PE}%R
8.3.44,%MKUKATPBASIS,%CMOVE,%VLIN,%P 1:LIN, 2:P222, 3:C_DIS C_DIS, 5:1, 7:CPDAT221
$BWDSTART=FALSE
LDAT_ACT=LCPDAT221
FDAT_ACT=FP222
BAS(#CP_PARAMS,1)
TQM_FIFO_READ(TM91)
TRIGGER WHEN DISTANCE=0 DELAY=TQM_DLY() DO iTQM_TRIGGERID=91
TRIGGER WHEN DISTANCE=0 DELAY=TQM_DLY() DO TQM_START_MON(TM91) PRIO = -1
TRIGGER WHEN DISTANCE=1 DELAY=0 DO TQM_SWAP_VALUES(TM91) PRIO = -1
LIN XP222 C_DIS C_DIS
:ENDFOLD
:FOLD   LIN      P223   CONT   Vel=1   m/s   CPDAT222   Tool[10]:b1   Base[14]:b1   CD;%{PE}%R
8.3.44,%MKUKATPBASIS,%CMOVE,%VLIN,%P 1:LIN, 2:P223, 3:C_DIS C_DIS, 5:1, 7:CPDAT222
$BWDSTART=FALSE
LDAT_ACT=LCPDAT222
FDAT_ACT=FP223

```

```

BAS(#CP_PARAMS,1)
TQM_FIFO_READ(TM92)
TRIGGER WHEN DISTANCE=0 DELAY=TQM_DLY() DO iTQM_TRIGGERID=92
TRIGGER WHEN DISTANCE=0 DELAY=TQM_DLY() DO TQM_START_MON(TM92) PRIO = -1
TRIGGER WHEN DISTANCE=1 DELAY=0 DO TQM_SWAP_VALUES(TM92) PRIO = -1
LIN XP223 C_DIS C_DIS
:ENDFOLD
:FOLD LIN P224 CONT Vel=1 m/s CPDAT223 Tool[10]:b1 Base[14]:b1 CD;%{PE}%R
8.3.44,%MKUKATPBASIS,%CMOVE,%VLIN,%P 1:LIN, 2:P224, 3:C_DIS C_DIS, 5:1, 7:CPDAT223
$BWDSTART=FALSE
LDAT_ACT=LCPDAT223
FDAT_ACT=FP224
BAS(#CP_PARAMS,1)
TQM_FIFO_READ(TM93)
TRIGGER WHEN DISTANCE=0 DELAY=TQM_DLY() DO iTQM_TRIGGERID=93
TRIGGER WHEN DISTANCE=0 DELAY=TQM_DLY() DO TQM_START_MON(TM93) PRIO = -1
TRIGGER WHEN DISTANCE=1 DELAY=0 DO TQM_SWAP_VALUES(TM93) PRIO = -1
LIN XP224 C_DIS C_DIS
:ENDFOLD
:FOLD LIN P225 CONT Vel=1 m/s CPDAT224 Tool[10]:b1 Base[14]:b1 CD;%{PE}%R
8.3.44,%MKUKATPBASIS,%CMOVE,%VLIN,%P 1:LIN, 2:P225, 3:C_DIS C_DIS, 5:1, 7:CPDAT224
$BWDSTART=FALSE
LDAT_ACT=LCPDAT224
FDAT_ACT=FP225
BAS(#CP_PARAMS,1)
TQM_FIFO_READ(TM94)
TRIGGER WHEN DISTANCE=0 DELAY=TQM_DLY() DO iTQM_TRIGGERID=94
TRIGGER WHEN DISTANCE=0 DELAY=TQM_DLY() DO TQM_START_MON(TM94) PRIO = -1
TRIGGER WHEN DISTANCE=1 DELAY=0 DO TQM_SWAP_VALUES(TM94) PRIO = -1
LIN XP225 C_DIS C_DIS
:ENDFOLD
:FOLD LIN P227 CONT Vel=1 m/s CPDAT226 Tool[10]:b1 Base[14]:b1 CD;%{PE}%R
8.3.44,%MKUKATPBASIS,%CMOVE,%VLIN,%P 1:LIN, 2:P227, 3:C_DIS C_DIS, 5:1, 7:CPDAT226
$BWDSTART=FALSE
LDAT_ACT=LCPDAT226
FDAT_ACT=FP227
BAS(#CP_PARAMS,1)
TQM_FIFO_READ(TM96)
TRIGGER WHEN DISTANCE=0 DELAY=TQM_DLY() DO iTQM_TRIGGERID=96
TRIGGER WHEN DISTANCE=0 DELAY=TQM_DLY() DO TQM_START_MON(TM96) PRIO = -1
TRIGGER WHEN DISTANCE=1 DELAY=0 DO TQM_SWAP_VALUES(TM96) PRIO = -1
LIN XP227 C_DIS C_DIS
:ENDFOLD
:FOLD LIN P228 CONT Vel=1 m/s CPDAT227 Tool[10]:b1 Base[14]:b1 CD;%{PE}%R
8.3.44,%MKUKATPBASIS,%CMOVE,%VLIN,%P 1:LIN, 2:P228, 3:C_DIS C_DIS, 5:1, 7:CPDAT227
$BWDSTART=FALSE
LDAT_ACT=LCPDAT227
FDAT_ACT=FP228
BAS(#CP_PARAMS,1)
TQM_FIFO_READ(TM97)
TRIGGER WHEN DISTANCE=0 DELAY=TQM_DLY() DO iTQM_TRIGGERID=97
TRIGGER WHEN DISTANCE=0 DELAY=TQM_DLY() DO TQM_START_MON(TM97) PRIO = -1
TRIGGER WHEN DISTANCE=1 DELAY=0 DO TQM_SWAP_VALUES(TM97) PRIO = -1
LIN XP228 C_DIS C_DIS
:ENDFOLD
:FOLD LIN P229 CONT Vel=1 m/s CPDAT228 Tool[10]:b1 Base[14]:b1 CD;%{PE}%R
8.3.44,%MKUKATPBASIS,%CMOVE,%VLIN,%P 1:LIN, 2:P229, 3:C_DIS C_DIS, 5:1, 7:CPDAT228
$BWDSTART=FALSE
LDAT_ACT=LCPDAT228
FDAT_ACT=FP229
BAS(#CP_PARAMS,1)
TQM_FIFO_READ(TM98)
TRIGGER WHEN DISTANCE=0 DELAY=TQM_DLY() DO iTQM_TRIGGERID=98
TRIGGER WHEN DISTANCE=0 DELAY=TQM_DLY() DO TQM_START_MON(TM98) PRIO = -1
TRIGGER WHEN DISTANCE=1 DELAY=0 DO TQM_SWAP_VALUES(TM98) PRIO = -1
LIN XP229 C_DIS C_DIS
:ENDFOLD
:FOLD LIN P230 CONT Vel=1 m/s CPDAT229 Tool[10]:b1 Base[14]:b1 CD;%{PE}%R
8.3.44,%MKUKATPBASIS,%CMOVE,%VLIN,%P 1:LIN, 2:P230, 3:C_DIS C_DIS, 5:1, 7:CPDAT229
$BWDSTART=FALSE
LDAT_ACT=LCPDAT229
FDAT_ACT=FP230
BAS(#CP_PARAMS,1)
TQM_FIFO_READ(TM99)
TRIGGER WHEN DISTANCE=0 DELAY=TQM_DLY() DO iTQM_TRIGGERID=99

```

```

TRIGGER WHEN DISTANCE=0 DELAY=TQM_DLY() DO TQM_START_MON(TM99) PRIO = -1
TRIGGER WHEN DISTANCE=1 DELAY=0 DO TQM_SWAP_VALUES(TM99) PRIO = -1
LIN XP230 C_DIS C_DIS
;ENDFOLD
:FOLD   LIN    P231   CONT    Vel=1    m/s    CPDAT230   Tool[10]:b1   Base[14]:b1   CD;%{PE}%R
8.3.44,%MKUKATPBASIS,%CMOVE,%VLIN,%P 1:LIN, 2:P231, 3:C_DIS C_DIS, 5:1, 7:CPDAT230
$BWDSTART=FALSE
LDAT_ACT=LCPDAT230
FDAT_ACT=FP231
BAS(#CP_PARAMS,1)
TQM_FIFO_READ(TM100)
TRIGGER WHEN DISTANCE=0 DELAY=TQM_DLY() DO iTQM_TRIGGERID=100
TRIGGER WHEN DISTANCE=0 DELAY=TQM_DLY() DO TQM_START_MON(TM100) PRIO = -1
TRIGGER WHEN DISTANCE=1 DELAY=0 DO TQM_SWAP_VALUES(TM100) PRIO = -1
LIN XP231 C_DIS C_DIS
;ENDFOLD
:FOLD   LIN    P232   CONT    Vel=1    m/s    CPDAT231   Tool[10]:b1   Base[14]:b1   CD;%{PE}%R
8.3.44,%MKUKATPBASIS,%CMOVE,%VLIN,%P 1:LIN, 2:P232, 3:C_DIS C_DIS, 5:1, 7:CPDAT231
$BWDSTART=FALSE
LDAT_ACT=LCPDAT231
FDAT_ACT=FP232
BAS(#CP_PARAMS,1)
TQM_FIFO_READ(TM101)
TRIGGER WHEN DISTANCE=0 DELAY=TQM_DLY() DO iTQM_TRIGGERID=101
TRIGGER WHEN DISTANCE=0 DELAY=TQM_DLY() DO TQM_START_MON(TM101) PRIO = -1
TRIGGER WHEN DISTANCE=1 DELAY=0 DO TQM_SWAP_VALUES(TM101) PRIO = -1
LIN XP232 C_DIS C_DIS
;ENDFOLD
:FOLD   LIN    P233   CONT    Vel=1    m/s    CPDAT232   Tool[10]:b1   Base[14]:b1   CD;%{PE}%R
8.3.44,%MKUKATPBASIS,%CMOVE,%VLIN,%P 1:LIN, 2:P233, 3:C_DIS C_DIS, 5:1, 7:CPDAT232
$BWDSTART=FALSE
LDAT_ACT=LCPDAT232
FDAT_ACT=FP233
BAS(#CP_PARAMS,1)
TQM_FIFO_READ(TM102)
TRIGGER WHEN DISTANCE=0 DELAY=TQM_DLY() DO iTQM_TRIGGERID=102
TRIGGER WHEN DISTANCE=0 DELAY=TQM_DLY() DO TQM_START_MON(TM102) PRIO = -1
TRIGGER WHEN DISTANCE=1 DELAY=0 DO TQM_SWAP_VALUES(TM102) PRIO = -1
LIN XP233 C_DIS C_DIS
;ENDFOLD
:FOLD   LIN    P234   CONT    Vel=1    m/s    CPDAT233   Tool[10]:b1   Base[14]:b1   CD;%{PE}%R
8.3.44,%MKUKATPBASIS,%CMOVE,%VLIN,%P 1:LIN, 2:P234, 3:C_DIS C_DIS, 5:1, 7:CPDAT233
$BWDSTART=FALSE
LDAT_ACT=LCPDAT233
FDAT_ACT=FP234
BAS(#CP_PARAMS,1)
TQM_FIFO_READ(TM103)
TRIGGER WHEN DISTANCE=0 DELAY=TQM_DLY() DO iTQM_TRIGGERID=103
TRIGGER WHEN DISTANCE=0 DELAY=TQM_DLY() DO TQM_START_MON(TM103) PRIO = -1
TRIGGER WHEN DISTANCE=1 DELAY=0 DO TQM_SWAP_VALUES(TM103) PRIO = -1
LIN XP234 C_DIS C_DIS
;ENDFOLD
:FOLD   LIN    P235   CONT    Vel=1    m/s    CPDAT234   Tool[10]:b1   Base[14]:b1   CD;%{PE}%R
8.3.44,%MKUKATPBASIS,%CMOVE,%VLIN,%P 1:LIN, 2:P235, 3:C_DIS C_DIS, 5:1, 7:CPDAT234
$BWDSTART=FALSE
LDAT_ACT=LCPDAT234
FDAT_ACT=FP235
BAS(#CP_PARAMS,1)
TQM_FIFO_READ(TM104)
TRIGGER WHEN DISTANCE=0 DELAY=TQM_DLY() DO iTQM_TRIGGERID=104
TRIGGER WHEN DISTANCE=0 DELAY=TQM_DLY() DO TQM_START_MON(TM104) PRIO = -1
TRIGGER WHEN DISTANCE=1 DELAY=0 DO TQM_SWAP_VALUES(TM104) PRIO = -1
LIN XP235 C_DIS C_DIS
;ENDFOLD
:FOLD   LIN    P236   CONT    Vel=1    m/s    CPDAT235   Tool[10]:b1   Base[14]:b1   CD;%{PE}%R
8.3.44,%MKUKATPBASIS,%CMOVE,%VLIN,%P 1:LIN, 2:P236, 3:C_DIS C_DIS, 5:1, 7:CPDAT235
$BWDSTART=FALSE
LDAT_ACT=LCPDAT235
FDAT_ACT=FP236
BAS(#CP_PARAMS,1)
TQM_FIFO_READ(TM105)
TRIGGER WHEN DISTANCE=0 DELAY=TQM_DLY() DO iTQM_TRIGGERID=105
TRIGGER WHEN DISTANCE=0 DELAY=TQM_DLY() DO TQM_START_MON(TM105) PRIO = -1
TRIGGER WHEN DISTANCE=1 DELAY=0 DO TQM_SWAP_VALUES(TM105) PRIO = -1
LIN XP236 C_DIS C_DIS

```

```

:ENDFOLD
:FOLD   LIN   P237   CONT   Vel=1   m/s   CPDAT236   Tool[10]:b1   Base[14]:b1   CD;%{PE}%R
8.3.44,%MKUKATPBASIS,%CMOVE,%VLIN,%P 1:LIN, 2:P237, 3:C_DIS C_DIS, 5:1, 7:CPDAT236
$BWDSTART=FALSE
LDAT_ACT=LCPDAT236
FDAT_ACT=FP237
BAS(#CP_PARAMS,1)
TQM_FIFO_READ(TM106)
TRIGGER WHEN DISTANCE=0 DELAY=TQM_DLY() DO iTQM_TRIGGERID=106
TRIGGER WHEN DISTANCE=0 DELAY=TQM_DLY() DO TQM_START_MON(TM106) PRIO = -1
TRIGGER WHEN DISTANCE=1 DELAY=0 DO TQM_SWAP_VALUES(TM106) PRIO = -1
LIN XP237 C_DIS C_DIS
:ENDFOLD
:FOLD   LIN   P238   CONT   Vel=1   m/s   CPDAT237   Tool[10]:b1   Base[14]:b1   CD;%{PE}%R
8.3.44,%MKUKATPBASIS,%CMOVE,%VLIN,%P 1:LIN, 2:P238, 3:C_DIS C_DIS, 5:1, 7:CPDAT237
$BWDSTART=FALSE
LDAT_ACT=LCPDAT237
FDAT_ACT=FP238
BAS(#CP_PARAMS,1)
TQM_FIFO_READ(TM107)
TRIGGER WHEN DISTANCE=0 DELAY=TQM_DLY() DO iTQM_TRIGGERID=107
TRIGGER WHEN DISTANCE=0 DELAY=TQM_DLY() DO TQM_START_MON(TM107) PRIO = -1
TRIGGER WHEN DISTANCE=1 DELAY=0 DO TQM_SWAP_VALUES(TM107) PRIO = -1
LIN XP238 C_DIS C_DIS
:ENDFOLD
:FOLD   LIN   P239   CONT   Vel=1   m/s   CPDAT238   Tool[10]:b1   Base[14]:b1   CD;%{PE}%R
8.3.44,%MKUKATPBASIS,%CMOVE,%VLIN,%P 1:LIN, 2:P239, 3:C_DIS C_DIS, 5:1, 7:CPDAT238
$BWDSTART=FALSE
LDAT_ACT=LCPDAT238
FDAT_ACT=FP239
BAS(#CP_PARAMS,1)
TQM_FIFO_READ(TM108)
TRIGGER WHEN DISTANCE=0 DELAY=TQM_DLY() DO iTQM_TRIGGERID=108
TRIGGER WHEN DISTANCE=0 DELAY=TQM_DLY() DO TQM_START_MON(TM108) PRIO = -1
TRIGGER WHEN DISTANCE=1 DELAY=0 DO TQM_SWAP_VALUES(TM108) PRIO = -1
LIN XP239 C_DIS C_DIS
:ENDFOLD
:FOLD   LIN   P240   CONT   Vel=1   m/s   CPDAT239   Tool[10]:b1   Base[14]:b1   CD;%{PE}%R
8.3.44,%MKUKATPBASIS,%CMOVE,%VLIN,%P 1:LIN, 2:P240, 3:C_DIS C_DIS, 5:1, 7:CPDAT239
$BWDSTART=FALSE
LDAT_ACT=LCPDAT239
FDAT_ACT=FP240
BAS(#CP_PARAMS,1)
TQM_FIFO_READ(TM109)
TRIGGER WHEN DISTANCE=0 DELAY=TQM_DLY() DO iTQM_TRIGGERID=109
TRIGGER WHEN DISTANCE=0 DELAY=TQM_DLY() DO TQM_START_MON(TM109) PRIO = -1
TRIGGER WHEN DISTANCE=1 DELAY=0 DO TQM_SWAP_VALUES(TM109) PRIO = -1
LIN XP240 C_DIS C_DIS
:ENDFOLD
:FOLD   LIN   P241   CONT   Vel=1   m/s   CPDAT240   Tool[10]:b1   Base[14]:b1   CD;%{PE}%R
8.3.44,%MKUKATPBASIS,%CMOVE,%VLIN,%P 1:LIN, 2:P241, 3:C_DIS C_DIS, 5:1, 7:CPDAT240
$BWDSTART=FALSE
LDAT_ACT=LCPDAT240
FDAT_ACT=FP241
BAS(#CP_PARAMS,1)
TQM_FIFO_READ(TM110)
TRIGGER WHEN DISTANCE=0 DELAY=TQM_DLY() DO iTQM_TRIGGERID=110
TRIGGER WHEN DISTANCE=0 DELAY=TQM_DLY() DO TQM_START_MON(TM110) PRIO = -1
TRIGGER WHEN DISTANCE=1 DELAY=0 DO TQM_SWAP_VALUES(TM110) PRIO = -1
LIN XP241 C_DIS C_DIS
:ENDFOLD
:FOLD   LIN   P242   CONT   Vel=1   m/s   CPDAT241   Tool[10]:b1   Base[14]:b1   CD;%{PE}%R
8.3.44,%MKUKATPBASIS,%CMOVE,%VLIN,%P 1:LIN, 2:P242, 3:C_DIS C_DIS, 5:1, 7:CPDAT241
$BWDSTART=FALSE
LDAT_ACT=LCPDAT241
FDAT_ACT=FP242
BAS(#CP_PARAMS,1)
TQM_FIFO_READ(TM111)
TRIGGER WHEN DISTANCE=0 DELAY=TQM_DLY() DO iTQM_TRIGGERID=111
TRIGGER WHEN DISTANCE=0 DELAY=TQM_DLY() DO TQM_START_MON(TM111) PRIO = -1
TRIGGER WHEN DISTANCE=1 DELAY=0 DO TQM_SWAP_VALUES(TM111) PRIO = -1
LIN XP242 C_DIS C_DIS
:ENDFOLD
:FOLD   LIN   P243   CONT   Vel=1   m/s   CPDAT242   Tool[10]:b1   Base[14]:b1   CD;%{PE}%R
8.3.44,%MKUKATPBASIS,%CMOVE,%VLIN,%P 1:LIN, 2:P243, 3:C_DIS C_DIS, 5:1, 7:CPDAT242

```

```

$BWDSTART=FALSE
LDAT_ACT=LCPDAT242
FDAT_ACT=FP243
BAS(#CP_PARAMS,1)
TQM_FIFO_READ(TM112)
TRIGGER WHEN DISTANCE=0 DELAY=TQM_DLY() DO iTQM_TRIGGERID=112
TRIGGER WHEN DISTANCE=0 DELAY=TQM_DLY() DO TQM_START_MON(TM112) PRIO = -1
TRIGGER WHEN DISTANCE=1 DELAY=0 DO TQM_SWAP_VALUES(TM112) PRIO = -1
LIN XP243 C_DIS C_DIS
:ENDFOLD
:FOLD LIN P244 CONT Vel=1 m/s CPDAT243 Tool[10]:b1 Base[14]:b1 CD;%{PE}%R
8.3.44,%MKUKATPBASIS,%CMOVE,%VLIN,%P 1:LIN, 2:P244, 3:C_DIS C_DIS, 5:1, 7:CPDAT243
$BWDSTART=FALSE
LDAT_ACT=LCPDAT243
FDAT_ACT=FP244
BAS(#CP_PARAMS,1)
TQM_FIFO_READ(TM113)
TRIGGER WHEN DISTANCE=0 DELAY=TQM_DLY() DO iTQM_TRIGGERID=113
TRIGGER WHEN DISTANCE=0 DELAY=TQM_DLY() DO TQM_START_MON(TM113) PRIO = -1
TRIGGER WHEN DISTANCE=1 DELAY=0 DO TQM_SWAP_VALUES(TM113) PRIO = -1
LIN XP244 C_DIS C_DIS
:ENDFOLD
:FOLD LIN P245 CONT Vel=1 m/s CPDAT244 Tool[10]:b1 Base[14]:b1 CD;%{PE}%R
8.3.44,%MKUKATPBASIS,%CMOVE,%VLIN,%P 1:LIN, 2:P245, 3:C_DIS C_DIS, 5:1, 7:CPDAT244
$BWDSTART=FALSE
LDAT_ACT=LCPDAT244
FDAT_ACT=FP245
BAS(#CP_PARAMS,1)
TQM_FIFO_READ(TM114)
TRIGGER WHEN DISTANCE=0 DELAY=TQM_DLY() DO iTQM_TRIGGERID=114
TRIGGER WHEN DISTANCE=0 DELAY=TQM_DLY() DO TQM_START_MON(TM114) PRIO = -1
TRIGGER WHEN DISTANCE=1 DELAY=0 DO TQM_SWAP_VALUES(TM114) PRIO = -1
LIN XP245 C_DIS C_DIS
:ENDFOLD
:FOLD LIN P246 CONT Vel=1 m/s CPDAT245 Tool[10]:b1 Base[14]:b1 CD;%{PE}%R
8.3.44,%MKUKATPBASIS,%CMOVE,%VLIN,%P 1:LIN, 2:P246, 3:C_DIS C_DIS, 5:1, 7:CPDAT245
$BWDSTART=FALSE
LDAT_ACT=LCPDAT245
FDAT_ACT=FP246
BAS(#CP_PARAMS,1)
TQM_FIFO_READ(TM115)
TRIGGER WHEN DISTANCE=0 DELAY=TQM_DLY() DO iTQM_TRIGGERID=115
TRIGGER WHEN DISTANCE=0 DELAY=TQM_DLY() DO TQM_START_MON(TM115) PRIO = -1
TRIGGER WHEN DISTANCE=1 DELAY=0 DO TQM_SWAP_VALUES(TM115) PRIO = -1
LIN XP246 C_DIS C_DIS
:ENDFOLD
:FOLD LIN P247 CONT Vel=1 m/s CPDAT246 Tool[10]:b1 Base[14]:b1 CD;%{PE}%R
8.3.44,%MKUKATPBASIS,%CMOVE,%VLIN,%P 1:LIN, 2:P247, 3:C_DIS C_DIS, 5:1, 7:CPDAT246
$BWDSTART=FALSE
LDAT_ACT=LCPDAT246
FDAT_ACT=FP247
BAS(#CP_PARAMS,1)
TQM_FIFO_READ(TM116)
TRIGGER WHEN DISTANCE=0 DELAY=TQM_DLY() DO iTQM_TRIGGERID=116
TRIGGER WHEN DISTANCE=0 DELAY=TQM_DLY() DO TQM_START_MON(TM116) PRIO = -1
TRIGGER WHEN DISTANCE=1 DELAY=0 DO TQM_SWAP_VALUES(TM116) PRIO = -1
LIN XP247 C_DIS C_DIS
:ENDFOLD
:FOLD LIN P248 CONT Vel=1 m/s CPDAT247 Tool[10]:b1 Base[14]:b1 CD;%{PE}%R
8.3.44,%MKUKATPBASIS,%CMOVE,%VLIN,%P 1:LIN, 2:P248, 3:C_DIS C_DIS, 5:1, 7:CPDAT247
$BWDSTART=FALSE
LDAT_ACT=LCPDAT247
FDAT_ACT=FP248
BAS(#CP_PARAMS,1)
TQM_FIFO_READ(TM117)
TRIGGER WHEN DISTANCE=0 DELAY=TQM_DLY() DO iTQM_TRIGGERID=117
TRIGGER WHEN DISTANCE=0 DELAY=TQM_DLY() DO TQM_START_MON(TM117) PRIO = -1
TRIGGER WHEN DISTANCE=1 DELAY=0 DO TQM_SWAP_VALUES(TM117) PRIO = -1
LIN XP248 C_DIS C_DIS
:ENDFOLD
:FOLD LIN P249 CONT Vel=1 m/s CPDAT248 Tool[10]:b1 Base[14]:b1 CD;%{PE}%R
8.3.44,%MKUKATPBASIS,%CMOVE,%VLIN,%P 1:LIN, 2:P249, 3:C_DIS C_DIS, 5:1, 7:CPDAT248
$BWDSTART=FALSE
LDAT_ACT=LCPDAT248
FDAT_ACT=FP249

```

```

BAS(#CP_PARAMS,1)
TQM_FIFO_READ(TM118)
TRIGGER WHEN DISTANCE=0 DELAY=TQM_DLY() DO iTQM_TRIGGERID=118
TRIGGER WHEN DISTANCE=0 DELAY=TQM_DLY() DO TQM_START_MON(TM118) PRIO = -1
TRIGGER WHEN DISTANCE=1 DELAY=0 DO TQM_SWAP_VALUES(TM118) PRIO = -1
LIN XP249 C_DIS C_DIS
:ENDFOLD
:FOLD LIN P250 CONT Vel=1 m/s CPDAT249 Tool[10]:b1 Base[14]:b1 CD;%{PE}%R
8.3.44,%MKUKATPBASIS,%CMOVE,%VLIN,%P 1:LIN, 2:P250, 3:C_DIS C_DIS, 5:1, 7:CPDAT249
$BWDSTART=FALSE
LDAT_ACT=LCPDAT249
FDAT_ACT=FP250
BAS(#CP_PARAMS,1)
TQM_FIFO_READ(TM119)
TRIGGER WHEN DISTANCE=0 DELAY=TQM_DLY() DO iTQM_TRIGGERID=119
TRIGGER WHEN DISTANCE=0 DELAY=TQM_DLY() DO TQM_START_MON(TM119) PRIO = -1
TRIGGER WHEN DISTANCE=1 DELAY=0 DO TQM_SWAP_VALUES(TM119) PRIO = -1
LIN XP250 C_DIS C_DIS
:ENDFOLD
:FOLD LIN P251 CONT Vel=1 m/s CPDAT250 Tool[10]:b1 Base[14]:b1 CD;%{PE}%R
8.3.44,%MKUKATPBASIS,%CMOVE,%VLIN,%P 1:LIN, 2:P251, 3:C_DIS C_DIS, 5:1, 7:CPDAT250
$BWDSTART=FALSE
LDAT_ACT=LCPDAT250
FDAT_ACT=FP251
BAS(#CP_PARAMS,1)
TQM_FIFO_READ(TM120)
TRIGGER WHEN DISTANCE=0 DELAY=TQM_DLY() DO iTQM_TRIGGERID=120
TRIGGER WHEN DISTANCE=0 DELAY=TQM_DLY() DO TQM_START_MON(TM120) PRIO = -1
TRIGGER WHEN DISTANCE=1 DELAY=0 DO TQM_SWAP_VALUES(TM120) PRIO = -1
LIN XP251 C_DIS C_DIS
:ENDFOLD
:FOLD LIN P252 CONT Vel=1 m/s CPDAT251 Tool[10]:b1 Base[14]:b1 CD;%{PE}%R
8.3.44,%MKUKATPBASIS,%CMOVE,%VLIN,%P 1:LIN, 2:P252, 3:C_DIS C_DIS, 5:1, 7:CPDAT251
$BWDSTART=FALSE
LDAT_ACT=LCPDAT251
FDAT_ACT=FP252
BAS(#CP_PARAMS,1)
TQM_FIFO_READ(TM121)
TRIGGER WHEN DISTANCE=0 DELAY=TQM_DLY() DO iTQM_TRIGGERID=121
TRIGGER WHEN DISTANCE=0 DELAY=TQM_DLY() DO TQM_START_MON(TM121) PRIO = -1
TRIGGER WHEN DISTANCE=1 DELAY=0 DO TQM_SWAP_VALUES(TM121) PRIO = -1
LIN XP252 C_DIS C_DIS
:ENDFOLD
:FOLD LIN P253 CONT Vel=1 m/s CPDAT252 Tool[10]:b1 Base[14]:b1 CD;%{PE}%R
8.3.44,%MKUKATPBASIS,%CMOVE,%VLIN,%P 1:LIN, 2:P253, 3:C_DIS C_DIS, 5:1, 7:CPDAT252
$BWDSTART=FALSE
LDAT_ACT=LCPDAT252
FDAT_ACT=FP253
BAS(#CP_PARAMS,1)
TQM_FIFO_READ(TM122)
TRIGGER WHEN DISTANCE=0 DELAY=TQM_DLY() DO iTQM_TRIGGERID=122
TRIGGER WHEN DISTANCE=0 DELAY=TQM_DLY() DO TQM_START_MON(TM122) PRIO = -1
TRIGGER WHEN DISTANCE=1 DELAY=0 DO TQM_SWAP_VALUES(TM122) PRIO = -1
LIN XP253 C_DIS C_DIS
:ENDFOLD
:FOLD LIN P255 CONT Vel=1 m/s CPDAT254 Tool[10]:b1 Base[14]:b1 CD;%{PE}%R
8.3.44,%MKUKATPBASIS,%CMOVE,%VLIN,%P 1:LIN, 2:P255, 3:C_DIS C_DIS, 5:1, 7:CPDAT254
$BWDSTART=FALSE
LDAT_ACT=LCPDAT254
FDAT_ACT=FP255
BAS(#CP_PARAMS,1)
TQM_FIFO_READ(TM124)
TRIGGER WHEN DISTANCE=0 DELAY=TQM_DLY() DO iTQM_TRIGGERID=124
TRIGGER WHEN DISTANCE=0 DELAY=TQM_DLY() DO TQM_START_MON(TM124) PRIO = -1
TRIGGER WHEN DISTANCE=1 DELAY=0 DO TQM_SWAP_VALUES(TM124) PRIO = -1
LIN XP255 C_DIS C_DIS
:ENDFOLD
ENDLOOP
END

```

Extensión .dat

```

&ACCESS RVP
&REL 357
&PARAM EDITMASK = *
&PARAM TEMPLATE = C:\KRC\Roboter\Template\vorgabe
&PARAM DISKPATH = KRC:\R1\TESISWEBO
DEFDAT pelton2
:FOLD EXTERNAL DECLARATIONS;% {PE}%MKUKATPBASIS,%CEXT,%VCOMMON,%P
:FOLD BASISTECH EXT;% {PE}%MKUKATPBASIS,%CEXT,%VEXT,%P
EXT BAS (BAS_COMMAND :IN,REAL :IN )
DECL INT SUCCESS
:ENDFOLD (BASISTECH EXT)
:FOLD USER EXT;% {E}%MKUKATPUSER,%CEXT,%VEXT,%P
:Make your modifications here

:ENDFOLD (USER EXT)
:ENDFOLD (EXTERNAL DECLARATIONS)
DECL BASIS_SUGG_T_LAST_BASIS={POINT1[] "P255          ",POINT2[] "P255          ",CP_PARAMS[] "CPDAT254
",PTP_PARAMS[] "PDAT1          ",CONT[] "C_DIS C_DIS          ",CP_VEL[] "1          ",PTP_VEL[] "100
",SYNC_PARAMS[] "SYNCDAT          ",SPL_NAME[] "S0          ",A_PARAMS[] "ADATO          "}
DECL E6POS XP1={X -887.927368,Y -946.831299,Z 596.597107,A 1.91744304,B 87.5199,C -165.420044,S 2,T 10,E1 0.0,E2 0.0,E3
0.0,E4 0.0,E5 0.0,E6 0.0}
DECL FDAT FP1={TOOL_NO 10,BASE_NO 14,IPO_FRAME #BASE,POINT2[] " ",TQ_STATE FALSE}
DECL PDAT PPDAT1={VEL 100.000,ACC 100.000,APO_DIST 100.000,APO_MODE #CDIS,GEAR_JERK 50.0000,EXAX_IGN 0}
DECL E6POS XP2={X -874.906189,Y -484.937225,Z 408.959656,A 166.161102,B 61.5457535,C -16.3448830,S 2,T 10,E1 0.0,E2 0.0,E3
0.0,E4 0.0,E5 0.0,E6 0.0}
DECL FDAT FP2={TOOL_NO 10,BASE_NO 14,IPO_FRAME #BASE,POINT2[] " ",TQ_STATE FALSE}
DECL LDAT LCPDAT1={VEL 2.00000,ACC 100.000,APO_DIST 100.000,APO_FAC 50.0000,AXIS_VEL 100.000,AXIS_ACC
100.000,ORI_TYP #JOINT,CIRC_TYP #BASE,JERK_FAC 50.0000,GEAR_JERK 50.0000,EXAX_IGN 0}
DECL E6POS XP3={X -941.863770,Y -353.226349,Z 396.332642,A 166.161728,B 61.5474396,C -23.4663143,S 2,T 10,E1 0.0,E2 0.0,E3
0.0,E4 0.0,E5 0.0,E6 0.0}
DECL FDAT FP3={TOOL_NO 10,BASE_NO 14,IPO_FRAME #BASE,POINT2[] " ",TQ_STATE FALSE}
DECL LDAT LCPDAT2={VEL 2.00000,ACC 100.000,APO_DIST 100.000,APO_FAC 50.0000,AXIS_VEL 100.000,AXIS_ACC
100.000,ORI_TYP #JOINT,CIRC_TYP #BASE,JERK_FAC 50.0000,GEAR_JERK 50.0000,EXAX_IGN 0}
DECL E6POS XP4={X -946.554077,Y -332.229584,Z 396.884491,A 166.161713,B 61.5474129,C -25.0189838,S 2,T 10,E1 0.0,E2 0.0,E3
0.0,E4 0.0,E5 0.0,E6 0.0}
DECL FDAT FP4={TOOL_NO 10,BASE_NO 14,IPO_FRAME #BASE,POINT2[] " ",TQ_STATE FALSE}
DECL LDAT LCPDAT3={VEL 2.00000,ACC 100.000,APO_DIST 100.000,APO_FAC 50.0000,AXIS_VEL 100.000,AXIS_ACC
100.000,ORI_TYP #JOINT,CIRC_TYP #BASE,JERK_FAC 50.0000,GEAR_JERK 50.0000,EXAX_IGN 0}
DECL E6POS XP5={X -946.374878,Y -331.525,Z 393.660248,A 166.330154,B 61.3647652,C -23.7121620,S 2,T 10,E1 0.0,E2 0.0,E3
0.0,E4 0.0,E5 0.0,E6 0.0}
DECL FDAT FP5={TOOL_NO 10,BASE_NO 14,IPO_FRAME #BASE,POINT2[] " ",TQ_STATE FALSE}
DECL LDAT LCPDAT4={VEL 2.00000,ACC 100.000,APO_DIST 100.000,APO_FAC 50.0000,AXIS_VEL 100.000,AXIS_ACC
100.000,ORI_TYP #JOINT,CIRC_TYP #BASE,JERK_FAC 50.0000,GEAR_JERK 50.0000,EXAX_IGN 0}
DECL E6POS XP6={X -943.278503,Y -330.794403,Z 392.111725,A 166.330154,B 61.3647575,C -22.6709328,S 2,T 10,E1 0.0,E2 0.0,E3
0.0,E4 0.0,E5 0.0,E6 0.0}
DECL FDAT FP6={TOOL_NO 10,BASE_NO 14,IPO_FRAME #BASE,POINT2[] " ",TQ_STATE FALSE}
DECL LDAT LCPDAT5={VEL 2.00000,ACC 100.000,APO_DIST 100.000,APO_FAC 50.0000,AXIS_VEL 100.000,AXIS_ACC
100.000,ORI_TYP #JOINT,CIRC_TYP #BASE,JERK_FAC 50.0000,GEAR_JERK 50.0000,EXAX_IGN 0}
DECL E6POS XP7={X -935.051697,Y -358.864288,Z 384.124542,A 166.330276,B 61.3649,C -18.5536232,S 2,T 10,E1 0.0,E2 0.0,E3
0.0,E4 0.0,E5 0.0,E6 0.0}
DECL FDAT FP7={TOOL_NO 10,BASE_NO 14,IPO_FRAME #BASE,POINT2[] " ",TQ_STATE FALSE}
DECL LDAT LCPDAT6={VEL 2.00000,ACC 100.000,APO_DIST 100.000,APO_FAC 50.0000,AXIS_VEL 100.000,AXIS_ACC
100.000,ORI_TYP #JOINT,CIRC_TYP #BASE,JERK_FAC 50.0000,GEAR_JERK 50.0000,EXAX_IGN 0}
DECL E6POS XP8={X -930.364258,Y -358.222656,Z 381.720459,A 166.330261,B 61.3648911,C -17.4489784,S 2,T 10,E1 0.0,E2 0.0,E3
0.0,E4 0.0,E5 0.0,E6 0.0}
DECL FDAT FP8={TOOL_NO 10,BASE_NO 14,IPO_FRAME #BASE,POINT2[] " ",TQ_STATE FALSE}
DECL LDAT LCPDAT7={VEL 2.00000,ACC 100.000,APO_DIST 100.000,APO_FAC 50.0000,AXIS_VEL 100.000,AXIS_ACC
100.000,ORI_TYP #JOINT,CIRC_TYP #BASE,JERK_FAC 50.0000,GEAR_JERK 50.0000,EXAX_IGN 0}
DECL E6POS XP9={X -924.309570,Y -357.582672,Z 378.590790,A 166.330261,B 61.3648796,C -14.0214882,S 2,T 10,E1 0.0,E2 0.0,E3
0.0,E4 0.0,E5 0.0,E6 0.0}
DECL FDAT FP9={TOOL_NO 10,BASE_NO 14,IPO_FRAME #BASE,POINT2[] " ",TQ_STATE FALSE}
DECL LDAT LCPDAT8={VEL 2.00000,ACC 100.000,APO_DIST 100.000,APO_FAC 50.0000,AXIS_VEL 100.000,AXIS_ACC
100.000,ORI_TYP #JOINT,CIRC_TYP #BASE,JERK_FAC 50.0000,GEAR_JERK 50.0000,EXAX_IGN 0}
DECL E6POS XP10={X -921.818848,Y -532.465454,Z 360.111328,A 166.343842,B 61.3761787,C 5.28077078,S 2,T 10,E1 0.0,E2 0.0,E3
0.0,E4 0.0,E5 0.0,E6 0.0}
DECL FDAT FP10={TOOL_NO 10,BASE_NO 14,IPO_FRAME #BASE,POINT2[] " ",TQ_STATE FALSE}
DECL LDAT LCPDAT9={VEL 2.00000,ACC 100.000,APO_DIST 100.000,APO_FAC 50.0000,AXIS_VEL 100.000,AXIS_ACC
100.000,ORI_TYP #JOINT,CIRC_TYP #BASE,JERK_FAC 50.0000,GEAR_JERK 50.0000,EXAX_IGN 0}
DECL E6POS XP11={X -915.289429,Y -513.809509,Z 353.735748,A 166.343811,B 61.3761711,C 5.95759296,S 2,T 10,E1 0.0,E2 0.0,E3
0.0,E4 0.0,E5 0.0,E6 0.0}
DECL FDAT FP11={TOOL_NO 10,BASE_NO 14,IPO_FRAME #BASE,POINT2[] " ",TQ_STATE FALSE}

```



```

DECL LDAT LCPDAT10={VEL 2.00000,ACC 100.000,APO_DIST 100.000,APO_FAC 50.0000,AXIS_VEL 100.000,AXIS_ACC
100.000,ORI_TYP #JOINT,CIRC_TYP #BASE,JERK_FAC 50.0000,GEAR_JERK 50.0000,EXAX_IGN 0}
DECL E6POS XP12={X -918.244385,Y -401.202606,Z 367.024689,A 166.330688,B 61.3653107,C -8.81272221,S 2,T 10,E1 0.0,E2 0.0,E3
0.0,E4 0.0,E5 0.0,E6 0.0}
DECL FDAT FP12={TOOL_NO 10,BASE_NO 14,IPO_FRAME #BASE,POINT2[] " ",TQ_STATE FALSE}
DECL LDAT LCPDAT11={VEL 2.00000,ACC 100.000,APO_DIST 100.000,APO_FAC 50.0000,AXIS_VEL 100.000,AXIS_ACC
100.000,ORI_TYP #JOINT,CIRC_TYP #BASE,JERK_FAC 50.0000,GEAR_JERK 50.0000,EXAX_IGN 0}
DECL E6POS XP13={X -915.512512,Y -423.837,Z 365.350952,A 166.341888,B 61.3729,C -4.90292263,S 2,T 10,E1 0.0,E2 0.0,E3 0.0,E4
0.0,E5 0.0,E6 0.0}
DECL FDAT FP13={TOOL_NO 10,BASE_NO 14,IPO_FRAME #BASE,POINT2[] " ",TQ_STATE FALSE}
DECL LDAT LCPDAT12={VEL 2.00000,ACC 100.000,APO_DIST 100.000,APO_FAC 50.0000,AXIS_VEL 100.000,AXIS_ACC
100.000,ORI_TYP #JOINT,CIRC_TYP #BASE,JERK_FAC 50.0000,GEAR_JERK 50.0000,EXAX_IGN 0}
DECL E6POS XP14={X -915.512512,Y -423.837,Z 365.350952,A 166.341888,B 61.3729,C -4.90292263,S 2,T 10,E1 0.0,E2 0.0,E3 0.0,E4
0.0,E5 0.0,E6 0.0}
DECL FDAT FP14={TOOL_NO 10,BASE_NO 14,IPO_FRAME #BASE,POINT2[] " ",TQ_STATE FALSE}
DECL LDAT LCPDAT13={VEL 2.00000,ACC 100.000,APO_DIST 100.000,APO_FAC 50.0000,AXIS_VEL 100.000,AXIS_ACC
100.000,ORI_TYP #JOINT,CIRC_TYP #BASE,JERK_FAC 50.0000,GEAR_JERK 50.0000,EXAX_IGN 0}
DECL E6POS XP15={X -913.365540,Y -481.100220,Z 353.098877,A 166.354492,B 61.3826141,C 2.10024929,S 2,T 10,E1 0.0,E2 0.0,E3
0.0,E4 0.0,E5 0.0,E6 0.0}
DECL FDAT FP15={TOOL_NO 10,BASE_NO 14,IPO_FRAME #BASE,POINT2[] " ",TQ_STATE FALSE}
DECL LDAT LCPDAT14={VEL 2.00000,ACC 100.000,APO_DIST 100.000,APO_FAC 50.0000,AXIS_VEL 100.000,AXIS_ACC
100.000,ORI_TYP #JOINT,CIRC_TYP #BASE,JERK_FAC 50.0000,GEAR_JERK 50.0000,EXAX_IGN 0}
DECL E6POS XP16={X -913.365540,Y -481.100220,Z 353.098877,A 166.354492,B 61.3826141,C 2.10024929,S 2,T 10,E1 0.0,E2 0.0,E3
0.0,E4 0.0,E5 0.0,E6 0.0}
DECL FDAT FP16={TOOL_NO 10,BASE_NO 14,IPO_FRAME #BASE,POINT2[] " ",TQ_STATE FALSE}
DECL LDAT LCPDAT15={VEL 2.00000,ACC 100.000,APO_DIST 100.000,APO_FAC 50.0000,AXIS_VEL 100.000,AXIS_ACC
100.000,ORI_TYP #JOINT,CIRC_TYP #BASE,JERK_FAC 50.0000,GEAR_JERK 50.0000,EXAX_IGN 0}
DECL E6POS XP17={X -924.817871,Y -504.798767,Z 351.613129,A 166.354507,B 61.3826065,C 2.10025,S 2,T 10,E1 0.0,E2 0.0,E3
0.0,E4 0.0,E5 0.0,E6 0.0}
DECL FDAT FP17={TOOL_NO 10,BASE_NO 14,IPO_FRAME #BASE,POINT2[] " ",TQ_STATE FALSE}
DECL LDAT LCPDAT16={VEL 2.00000,ACC 100.000,APO_DIST 100.000,APO_FAC 50.0000,AXIS_VEL 100.000,AXIS_ACC
100.000,ORI_TYP #JOINT,CIRC_TYP #BASE,JERK_FAC 50.0000,GEAR_JERK 50.0000,EXAX_IGN 0}
DECL E6POS XP18={X -934.549377,Y -518.091553,Z 348.308655,A 166.354507,B 61.3826,C 2.10025048,S 2,T 10,E1 0.0,E2 0.0,E3
0.0,E4 0.0,E5 0.0,E6 0.0}
DECL FDAT FP18={TOOL_NO 10,BASE_NO 14,IPO_FRAME #BASE,POINT2[] " ",TQ_STATE FALSE}
DECL LDAT LCPDAT17={VEL 2.00000,ACC 100.000,APO_DIST 100.000,APO_FAC 50.0000,AXIS_VEL 100.000,AXIS_ACC
100.000,ORI_TYP #JOINT,CIRC_TYP #BASE,JERK_FAC 50.0000,GEAR_JERK 50.0000,EXAX_IGN 0}
DECL E6POS XP19={X -937.336914,Y -474.673553,Z 351.103729,A 166.362595,B 61.3901978,C -3.73483682,S 2,T 10,E1 0.0,E2 0.0,E3
0.0,E4 0.0,E5 0.0,E6 0.0}
DECL FDAT FP19={TOOL_NO 10,BASE_NO 14,IPO_FRAME #BASE,POINT2[] " ",TQ_STATE FALSE}
DECL LDAT LCPDAT18={VEL 2.00000,ACC 100.000,APO_DIST 100.000,APO_FAC 50.0000,AXIS_VEL 100.000,AXIS_ACC
100.000,ORI_TYP #JOINT,CIRC_TYP #BASE,JERK_FAC 50.0000,GEAR_JERK 50.0000,EXAX_IGN 0}
DECL E6POS XP20={X -957.941223,Y -335.841614,Z 383.954773,A 166.374786,B 61.3969498,C -24.1083851,S 2,T 10,E1 0.0,E2 0.0,E3
0.0,E4 0.0,E5 0.0,E6 0.0}
DECL FDAT FP20={TOOL_NO 10,BASE_NO 14,IPO_FRAME #BASE,POINT2[] " ",TQ_STATE FALSE}
DECL LDAT LCPDAT19={VEL 2.00000,ACC 100.000,APO_DIST 100.000,APO_FAC 50.0000,AXIS_VEL 100.000,AXIS_ACC
100.000,ORI_TYP #JOINT,CIRC_TYP #BASE,JERK_FAC 50.0000,GEAR_JERK 50.0000,EXAX_IGN 0}
DECL E6POS XP21={X -951.847839,Y -348.139618,Z 386.372894,A 166.374786,B 61.3969498,C -24.1083851,S 2,T 10,E1 0.0,E2 0.0,E3
0.0,E4 0.0,E5 0.0,E6 0.0}
DECL FDAT FP21={TOOL_NO 10,BASE_NO 14,IPO_FRAME #BASE,POINT2[] " ",TQ_STATE FALSE}
DECL LDAT LCPDAT20={VEL 2.00000,ACC 100.000,APO_DIST 100.000,APO_FAC 50.0000,AXIS_VEL 100.000,AXIS_ACC
100.000,ORI_TYP #JOINT,CIRC_TYP #BASE,JERK_FAC 50.0000,GEAR_JERK 50.0000,EXAX_IGN 0}
DECL E6POS XP22={X -945.323669,Y -362.531708,Z 375.873322,A 166.374786,B 61.3969498,C -24.1083851,S 2,T 10,E1 0.0,E2 0.0,E3
0.0,E4 0.0,E5 0.0,E6 0.0}
DECL FDAT FP22={TOOL_NO 10,BASE_NO 14,IPO_FRAME #BASE,POINT2[] " ",TQ_STATE FALSE}
DECL LDAT LCPDAT21={VEL 2.00000,ACC 100.000,APO_DIST 100.000,APO_FAC 50.0000,AXIS_VEL 100.000,AXIS_ACC
100.000,ORI_TYP #JOINT,CIRC_TYP #BASE,JERK_FAC 50.0000,GEAR_JERK 50.0000,EXAX_IGN 0}
DECL E6POS XP23={X -965.069824,Y -309.471161,Z 386.834198,A -176.554565,B 64.8030701,C -15.9954901,S 2,T 10,E1 0.0,E2 0.0,E3
0.0,E4 0.0,E5 0.0,E6 0.0}
DECL FDAT FP23={TOOL_NO 10,BASE_NO 14,IPO_FRAME #BASE,POINT2[] " ",TQ_STATE FALSE}
DECL LDAT LCPDAT22={VEL 2.00000,ACC 100.000,APO_DIST 100.000,APO_FAC 50.0000,AXIS_VEL 100.000,AXIS_ACC
100.000,ORI_TYP #JOINT,CIRC_TYP #BASE,JERK_FAC 50.0000,GEAR_JERK 50.0000,EXAX_IGN 0}
DECL E6POS XP24={X -978.616943,Y -296.778717,Z 381.014069,A -176.554565,B 64.8030701,C -15.9954863,S 2,T 10,E1 0.0,E2 0.0,E3
0.0,E4 0.0,E5 0.0,E6 0.0}
DECL FDAT FP24={TOOL_NO 10,BASE_NO 14,IPO_FRAME #BASE,POINT2[] " ",TQ_STATE FALSE}
DECL LDAT LCPDAT23={VEL 2.00000,ACC 100.000,APO_DIST 100.000,APO_FAC 50.0000,AXIS_VEL 100.000,AXIS_ACC
100.000,ORI_TYP #JOINT,CIRC_TYP #BASE,JERK_FAC 50.0000,GEAR_JERK 50.0000,EXAX_IGN 0}
DECL E6POS XP25={X -992.575378,Y -285.189301,Z 377.864441,A -176.554550,B 64.8030701,C -15.9954834,S 2,T 10,E1 0.0,E2 0.0,E3
0.0,E4 0.0,E5 0.0,E6 0.0}
DECL FDAT FP25={TOOL_NO 10,BASE_NO 14,IPO_FRAME #BASE,POINT2[] " ",TQ_STATE FALSE}
DECL LDAT LCPDAT24={VEL 2.00000,ACC 100.000,APO_DIST 100.000,APO_FAC 50.0000,AXIS_VEL 100.000,AXIS_ACC
100.000,ORI_TYP #JOINT,CIRC_TYP #BASE,JERK_FAC 50.0000,GEAR_JERK 50.0000,EXAX_IGN 0}
DECL E6POS XP26={X -955.113953,Y -392.649536,Z 360.019867,A -176.429367,B 64.8156891,C 0.535386324,S 2,T 10,E1 0.0,E2 0.0,E3
0.0,E4 0.0,E5 0.0,E6 0.0}
DECL FDAT FP26={TOOL_NO 10,BASE_NO 14,IPO_FRAME #BASE,POINT2[] " ",TQ_STATE FALSE}

```

```

DECL LDAT LCPDAT25={VEL 2.00000,ACC 100.000,APO_DIST 100.000,APO_FAC 50.0000,AXIS_VEL 100.000,AXIS_ACC
100.000,ORI_TYP #JOINT,CIRC_TYP #BASE,JERK_FAC 50.0000,GEAR_JERK 50.0000,EXAX_IGN 0}
DECL E6POS XP27={X -940.267639,Y -572.832275,Z 362.347,A -176.379501,B 64.8218155,C 25.1287422,S 2,T 10,E1 0.0,E2 0.0,E3
0.0,E4 0.0,E5 0.0,E6 0.0}
DECL FDAT FP27={TOOL_NO 10,BASE_NO 14,IPO_FRAME #BASE,POINT2[] " ",TQ_STATE FALSE}
DECL LDAT LCPDAT26={VEL 2.00000,ACC 100.000,APO_DIST 100.000,APO_FAC 50.0000,AXIS_VEL 100.000,AXIS_ACC
100.000,ORI_TYP #JOINT,CIRC_TYP #BASE,JERK_FAC 50.0000,GEAR_JERK 50.0000,EXAX_IGN 0}
DECL E6POS XP28={X -912.637390,Y -548.667419,Z 371.129974,A -176.379959,B 64.8218842,C 25.1284847,S 2,T 10,E1 0.0,E2 0.0,E3
0.0,E4 0.0,E5 0.0,E6 0.0}
DECL FDAT FP28={TOOL_NO 10,BASE_NO 14,IPO_FRAME #BASE,POINT2[] " ",TQ_STATE FALSE}
DECL LDAT LCPDAT27={VEL 2.00000,ACC 100.000,APO_DIST 100.000,APO_FAC 50.0000,AXIS_VEL 100.000,AXIS_ACC
100.000,ORI_TYP #JOINT,CIRC_TYP #BASE,JERK_FAC 50.0000,GEAR_JERK 50.0000,EXAX_IGN 0}
DECL E6POS XP29={X -913.583130,Y -535.917053,Z 356.739624,A -176.379974,B 64.8218842,C 25.1284771,S 2,T 10,E1 0.0,E2 0.0,E3
0.0,E4 0.0,E5 0.0,E6 0.0}
DECL FDAT FP29={TOOL_NO 10,BASE_NO 14,IPO_FRAME #BASE,POINT2[] " ",TQ_STATE FALSE}
DECL LDAT LCPDAT28={VEL 2.00000,ACC 100.000,APO_DIST 100.000,APO_FAC 50.0000,AXIS_VEL 100.000,AXIS_ACC
100.000,ORI_TYP #JOINT,CIRC_TYP #BASE,JERK_FAC 50.0000,GEAR_JERK 50.0000,EXAX_IGN 0}
DECL E6POS XP30={X -911.824646,Y -570.968323,Z 356.928314,A -176.352737,B 64.8286819,C 31.3329964,S 2,T 10,E1 0.0,E2 0.0,E3
0.0,E4 0.0,E5 0.0,E6 0.0}
DECL FDAT FP30={TOOL_NO 10,BASE_NO 14,IPO_FRAME #BASE,POINT2[] " ",TQ_STATE FALSE}
DECL LDAT LCPDAT29={VEL 2.00000,ACC 100.000,APO_DIST 100.000,APO_FAC 50.0000,AXIS_VEL 100.000,AXIS_ACC
100.000,ORI_TYP #JOINT,CIRC_TYP #BASE,JERK_FAC 50.0000,GEAR_JERK 50.0000,EXAX_IGN 0}
DECL E6POS XP31={X -928.386108,Y -602.122803,Z 365.627,A -176.352768,B 64.8286819,C 31.3329754,S 2,T 10,E1 0.0,E2 0.0,E3
0.0,E4 0.0,E5 0.0,E6 0.0}
DECL FDAT FP31={TOOL_NO 10,BASE_NO 14,IPO_FRAME #BASE,POINT2[] " ",TQ_STATE FALSE}
DECL LDAT LCPDAT30={VEL 2.00000,ACC 100.000,APO_DIST 100.000,APO_FAC 50.0000,AXIS_VEL 100.000,AXIS_ACC
100.000,ORI_TYP #JOINT,CIRC_TYP #BASE,JERK_FAC 50.0000,GEAR_JERK 50.0000,EXAX_IGN 0}
DECL E6POS XP32={X -955.041931,Y -613.696960,Z 363.557037,A -176.352814,B 64.8286743,C 31.3329391,S 2,T 10,E1 0.0,E2 0.0,E3
0.0,E4 0.0,E5 0.0,E6 0.0}
DECL FDAT FP32={TOOL_NO 10,BASE_NO 14,IPO_FRAME #BASE,POINT2[] " ",TQ_STATE FALSE}
DECL LDAT LCPDAT31={VEL 2.00000,ACC 100.000,APO_DIST 100.000,APO_FAC 50.0000,AXIS_VEL 100.000,AXIS_ACC
100.000,ORI_TYP #JOINT,CIRC_TYP #BASE,JERK_FAC 50.0000,GEAR_JERK 50.0000,EXAX_IGN 0}
DECL E6POS XP33={X -948.454895,Y -443.580475,Z 352.895752,A -175.978363,B 65.7810287,C 8.66144943,S 2,T 10,E1 0.0,E2 0.0,E3
0.0,E4 0.0,E5 0.0,E6 0.0}
DECL FDAT FP33={TOOL_NO 10,BASE_NO 14,IPO_FRAME #BASE,POINT2[] " ",TQ_STATE FALSE}
DECL LDAT LCPDAT32={VEL 2.00000,ACC 100.000,APO_DIST 100.000,APO_FAC 50.0000,AXIS_VEL 100.000,AXIS_ACC
100.000,ORI_TYP #JOINT,CIRC_TYP #BASE,JERK_FAC 50.0000,GEAR_JERK 50.0000,EXAX_IGN 0}
DECL E6POS XP34={X -950.180359,Y -453.834381,Z 353.993469,A -175.978363,B 65.7810287,C 8.66145134,S 2,T 10,E1 0.0,E2 0.0,E3
0.0,E4 0.0,E5 0.0,E6 0.0}
DECL FDAT FP34={TOOL_NO 10,BASE_NO 14,IPO_FRAME #BASE,POINT2[] " ",TQ_STATE FALSE}
DECL LDAT LCPDAT33={VEL 2.00000,ACC 100.000,APO_DIST 100.000,APO_FAC 50.0000,AXIS_VEL 100.000,AXIS_ACC
100.000,ORI_TYP #JOINT,CIRC_TYP #BASE,JERK_FAC 50.0000,GEAR_JERK 50.0000,EXAX_IGN 0}
DECL E6POS XP35={X -975.357666,Y -305.328461,Z 381.763855,A -176.554565,B 64.8030701,C -15.9954891,S 2,T 10,E1 0.0,E2 0.0,E3
0.0,E4 0.0,E5 0.0,E6 0.0}
DECL FDAT FP35={TOOL_NO 10,BASE_NO 14,IPO_FRAME #BASE,POINT2[] " ",TQ_STATE FALSE}
DECL LDAT LCPDAT34={VEL 2.00000,ACC 100.000,APO_DIST 100.000,APO_FAC 50.0000,AXIS_VEL 100.000,AXIS_ACC
100.000,ORI_TYP #JOINT,CIRC_TYP #BASE,JERK_FAC 50.0000,GEAR_JERK 50.0000,EXAX_IGN 0}
DECL E6POS XP36={X -1045.93518,Y -205.595963,Z 399.678680,A -176.554047,B 64.8027115,C -27.5827847,S 2,T 10,E1 0.0,E2 0.0,E3
0.0,E4 0.0,E5 0.0,E6 0.0}
DECL FDAT FP36={TOOL_NO 10,BASE_NO 14,IPO_FRAME #BASE,POINT2[] " ",TQ_STATE FALSE}
DECL LDAT LCPDAT35={VEL 2.00000,ACC 100.000,APO_DIST 100.000,APO_FAC 50.0000,AXIS_VEL 100.000,AXIS_ACC
100.000,ORI_TYP #JOINT,CIRC_TYP #BASE,JERK_FAC 50.0000,GEAR_JERK 50.0000,EXAX_IGN 0}
DECL E6POS XP37={X -961.552,Y -361.723877,Z 361.517853,A -176.555511,B 64.8040085,C -3.08023405,S 2,T 10,E1 0.0,E2 0.0,E3
0.0,E4 0.0,E5 0.0,E6 0.0}
DECL FDAT FP37={TOOL_NO 10,BASE_NO 14,IPO_FRAME #BASE,POINT2[] " ",TQ_STATE FALSE}
DECL LDAT LCPDAT36={VEL 2.00000,ACC 100.000,APO_DIST 100.000,APO_FAC 50.0000,AXIS_VEL 100.000,AXIS_ACC
100.000,ORI_TYP #JOINT,CIRC_TYP #BASE,JERK_FAC 50.0000,GEAR_JERK 50.0000,EXAX_IGN 0}
DECL E6POS XP38={X -981.960388,Y -281.967468,Z 408.055328,A 179.531540,B 69.4964828,C -18.9222584,S 2,T 10,E1 0.0,E2 0.0,E3
0.0,E4 0.0,E5 0.0,E6 0.0}
DECL FDAT FP38={TOOL_NO 10,BASE_NO 14,IPO_FRAME #BASE,POINT2[] " ",TQ_STATE FALSE}
DECL LDAT LCPDAT37={VEL 2.00000,ACC 100.000,APO_DIST 100.000,APO_FAC 50.0000,AXIS_VEL 100.000,AXIS_ACC
100.000,ORI_TYP #JOINT,CIRC_TYP #BASE,JERK_FAC 50.0000,GEAR_JERK 50.0000,EXAX_IGN 0}
DECL E6POS XP39={X -932.062622,Y -401.324371,Z 396.242096,A -171.060822,B 70.4253845,C 7.56942129,S 2,T 10,E1 0.0,E2 0.0,E3
0.0,E4 0.0,E5 0.0,E6 0.0}
DECL FDAT FP39={TOOL_NO 10,BASE_NO 14,IPO_FRAME #BASE,POINT2[] " ",TQ_STATE FALSE}
DECL LDAT LCPDAT38={VEL 2.00000,ACC 100.000,APO_DIST 100.000,APO_FAC 50.0000,AXIS_VEL 100.000,AXIS_ACC
100.000,ORI_TYP #JOINT,CIRC_TYP #BASE,JERK_FAC 50.0000,GEAR_JERK 50.0000,EXAX_IGN 0}
DECL E6POS XP40={X -914.215698,Y -420.098450,Z 398.082306,A -171.059784,B 70.4256897,C 11.3253498,S 2,T 10,E1 0.0,E2 0.0,E3
0.0,E4 0.0,E5 0.0,E6 0.0}
DECL FDAT FP40={TOOL_NO 10,BASE_NO 14,IPO_FRAME #BASE,POINT2[] " ",TQ_STATE FALSE}
DECL LDAT LCPDAT39={VEL 2.00000,ACC 100.000,APO_DIST 100.000,APO_FAC 50.0000,AXIS_VEL 100.000,AXIS_ACC
100.000,ORI_TYP #JOINT,CIRC_TYP #BASE,JERK_FAC 50.0000,GEAR_JERK 50.0000,EXAX_IGN 0}
DECL E6POS XP41={X -892.422485,Y -485.323669,Z 403.962524,A -171.016663,B 70.4338303,C 20.6616402,S 2,T 10,E1 0.0,E2 0.0,E3
0.0,E4 0.0,E5 0.0,E6 0.0}
DECL FDAT FP41={TOOL_NO 10,BASE_NO 14,IPO_FRAME #BASE,POINT2[] " ",TQ_STATE FALSE}

```

```

DECL LDAT LCPDAT40={VEL 2.00000,ACC 100.000,APO_DIST 100.000,APO_FAC 50.0000,AXIS_VEL 100.000,AXIS_ACC
100.000,ORI_TYP #JOINT,CIRC_TYP #BASE,JERK_FAC 50.0000,GEAR_JERK 50.0000,EXAX_IGN 0}
DECL E6POS XP42={X -914.283081,Y -419.533081,Z 374.534821,A 166.130325,B 61.5305023,C -18.6437817,S 2,T 10,E1 0.0,E2 0.0,E3
0.0,E4 0.0,E5 0.0,E6 0.0}
DECL FDAT FP42={TOOL_NO 10,BASE_NO 14,IPO_FRAME #BASE,POINT2[] " ",TQ_STATE FALSE}
DECL LDAT LCPDAT41={VEL 2.00000,ACC 100.000,APO_DIST 100.000,APO_FAC 50.0000,AXIS_VEL 100.000,AXIS_ACC
100.000,ORI_TYP #JOINT,CIRC_TYP #BASE,JERK_FAC 50.0000,GEAR_JERK 50.0000,EXAX_IGN 0}
DECL E6POS XP43={X -921.190308,Y -356.708740,Z 384.612366,A 166.130341,B 61.5305061,C -18.6437817,S 2,T 10,E1 0.0,E2 0.0,E3
0.0,E4 0.0,E5 0.0,E6 0.0}
DECL FDAT FP43={TOOL_NO 10,BASE_NO 14,IPO_FRAME #BASE,POINT2[] " ",TQ_STATE FALSE}
DECL LDAT LCPDAT42={VEL 2.00000,ACC 100.000,APO_DIST 100.000,APO_FAC 50.0000,AXIS_VEL 100.000,AXIS_ACC
100.000,ORI_TYP #JOINT,CIRC_TYP #BASE,JERK_FAC 50.0000,GEAR_JERK 50.0000,EXAX_IGN 0}
DECL E6POS XP44={X -919.700439,Y -351.336395,Z 382.798126,A 166.130341,B 61.5305061,C -18.6437817,S 2,T 10,E1 0.0,E2 0.0,E3
0.0,E4 0.0,E5 0.0,E6 0.0}
DECL FDAT FP44={TOOL_NO 10,BASE_NO 14,IPO_FRAME #BASE,POINT2[] " ",TQ_STATE FALSE}
DECL LDAT LCPDAT43={VEL 2.00000,ACC 100.000,APO_DIST 100.000,APO_FAC 50.0000,AXIS_VEL 100.000,AXIS_ACC
100.000,ORI_TYP #JOINT,CIRC_TYP #BASE,JERK_FAC 50.0000,GEAR_JERK 50.0000,EXAX_IGN 0}
DECL E6POS XP45={X -920.028748,Y -347.834137,Z 385.400879,A 166.130341,B 61.5305061,C -18.6437798,S 2,T 10,E1 0.0,E2 0.0,E3
0.0,E4 0.0,E5 0.0,E6 0.0}
DECL FDAT FP45={TOOL_NO 10,BASE_NO 14,IPO_FRAME #BASE,POINT2[] " ",TQ_STATE FALSE}
DECL LDAT LCPDAT44={VEL 2.00000,ACC 100.000,APO_DIST 100.000,APO_FAC 50.0000,AXIS_VEL 100.000,AXIS_ACC
100.000,ORI_TYP #JOINT,CIRC_TYP #BASE,JERK_FAC 50.0000,GEAR_JERK 50.0000,EXAX_IGN 0}
DECL E6POS XP46={X -917.832092,Y -341.687561,Z 386.153229,A 166.130341,B 61.5305061,C -18.6437798,S 2,T 10,E1 0.0,E2 0.0,E3
0.0,E4 0.0,E5 0.0,E6 0.0}
DECL FDAT FP46={TOOL_NO 10,BASE_NO 14,IPO_FRAME #BASE,POINT2[] " ",TQ_STATE FALSE}
DECL LDAT LCPDAT45={VEL 2.00000,ACC 100.000,APO_DIST 100.000,APO_FAC 50.0000,AXIS_VEL 100.000,AXIS_ACC
100.000,ORI_TYP #JOINT,CIRC_TYP #BASE,JERK_FAC 50.0000,GEAR_JERK 50.0000,EXAX_IGN 0}
DECL E6POS XP47={X -915.358,Y -328.074524,Z 386.620239,A 166.130341,B 61.5305061,C -18.6437798,S 2,T 10,E1 0.0,E2 0.0,E3
0.0,E4 0.0,E5 0.0,E6 0.0}
DECL FDAT FP47={TOOL_NO 10,BASE_NO 14,IPO_FRAME #BASE,POINT2[] " ",TQ_STATE FALSE}
DECL LDAT LCPDAT46={VEL 2.00000,ACC 100.000,APO_DIST 100.000,APO_FAC 50.0000,AXIS_VEL 100.000,AXIS_ACC
100.000,ORI_TYP #JOINT,CIRC_TYP #BASE,JERK_FAC 50.0000,GEAR_JERK 50.0000,EXAX_IGN 0}
DECL E6POS XP48={X -899.209595,Y -435.387360,Z 358.113831,A 166.147614,B 61.5412,C 13.7454214,S 2,T 10,E1 0.0,E2 0.0,E3
0.0,E4 0.0,E5 0.0,E6 0.0}
DECL FDAT FP48={TOOL_NO 10,BASE_NO 14,IPO_FRAME #BASE,POINT2[] " ",TQ_STATE FALSE}
DECL LDAT LCPDAT47={VEL 2.00000,ACC 100.000,APO_DIST 100.000,APO_FAC 50.0000,AXIS_VEL 100.000,AXIS_ACC
100.000,ORI_TYP #JOINT,CIRC_TYP #BASE,JERK_FAC 50.0000,GEAR_JERK 50.0000,EXAX_IGN 0}
DECL E6POS XP49={X -901.826111,Y -449.217285,Z 357.721100,A 166.135757,B 61.5349617,C -3.74157214,S 2,T 10,E1 0.0,E2 0.0,E3
0.0,E4 0.0,E5 0.0,E6 0.0}
DECL FDAT FP49={TOOL_NO 10,BASE_NO 14,IPO_FRAME #BASE,POINT2[] " ",TQ_STATE FALSE}
DECL LDAT LCPDAT48={VEL 2.00000,ACC 100.000,APO_DIST 100.000,APO_FAC 50.0000,AXIS_VEL 100.000,AXIS_ACC
100.000,ORI_TYP #JOINT,CIRC_TYP #BASE,JERK_FAC 50.0000,GEAR_JERK 50.0000,EXAX_IGN 0}
DECL E6POS XP50={X -913.098450,Y -458.704803,Z 356.117279,A 166.135773,B 61.5349579,C -3.74156928,S 2,T 10,E1 0.0,E2 0.0,E3
0.0,E4 0.0,E5 0.0,E6 0.0}
DECL FDAT FP50={TOOL_NO 10,BASE_NO 14,IPO_FRAME #BASE,POINT2[] " ",TQ_STATE FALSE}
DECL LDAT LCPDAT49={VEL 2.00000,ACC 100.000,APO_DIST 100.000,APO_FAC 50.0000,AXIS_VEL 100.000,AXIS_ACC
100.000,ORI_TYP #JOINT,CIRC_TYP #BASE,JERK_FAC 50.0000,GEAR_JERK 50.0000,EXAX_IGN 0}
DECL E6POS XP51={X -919.160706,Y -467.450684,Z 354.596466,A 166.135773,B 61.5349541,C -3.74156547,S 2,T 10,E1 0.0,E2 0.0,E3
0.0,E4 0.0,E5 0.0,E6 0.0}
DECL FDAT FP51={TOOL_NO 10,BASE_NO 14,IPO_FRAME #BASE,POINT2[] " ",TQ_STATE FALSE}
DECL LDAT LCPDAT50={VEL 2.00000,ACC 100.000,APO_DIST 100.000,APO_FAC 50.0000,AXIS_VEL 100.000,AXIS_ACC
100.000,ORI_TYP #JOINT,CIRC_TYP #BASE,JERK_FAC 50.0000,GEAR_JERK 50.0000,EXAX_IGN 0}
DECL E6POS XP52={X -919.123657,Y -448.514130,Z 356.929352,A 166.658844,B 61.5673141,C -7.03623056,S 2,T 10,E1 0.0,E2 0.0,E3
0.0,E4 0.0,E5 0.0,E6 0.0}
DECL FDAT FP52={TOOL_NO 10,BASE_NO 14,IPO_FRAME #BASE,POINT2[] " ",TQ_STATE FALSE}
DECL LDAT LCPDAT51={VEL 2.00000,ACC 100.000,APO_DIST 100.000,APO_FAC 50.0000,AXIS_VEL 100.000,AXIS_ACC
100.000,ORI_TYP #JOINT,CIRC_TYP #BASE,JERK_FAC 50.0000,GEAR_JERK 50.0000,EXAX_IGN 0}
DECL E6POS XP53={X -915.467834,Y -454.063660,Z 358.314270,A 166.658844,B 61.5673141,C -7.03623,S 2,T 10,E1 0.0,E2 0.0,E3
0.0,E4 0.0,E5 0.0,E6 0.0}
DECL FDAT FP53={TOOL_NO 10,BASE_NO 14,IPO_FRAME #BASE,POINT2[] " ",TQ_STATE FALSE}
DECL LDAT LCPDAT52={VEL 2.00000,ACC 100.000,APO_DIST 100.000,APO_FAC 50.0000,AXIS_VEL 100.000,AXIS_ACC
100.000,ORI_TYP #JOINT,CIRC_TYP #BASE,JERK_FAC 50.0000,GEAR_JERK 50.0000,EXAX_IGN 0}
DECL E6POS XP54={X -912.813049,Y -460.788574,Z 357.843750,A 166.658844,B 61.5673141,C -7.03622961,S 2,T 10,E1 0.0,E2 0.0,E3
0.0,E4 0.0,E5 0.0,E6 0.0}
DECL FDAT FP54={TOOL_NO 10,BASE_NO 14,IPO_FRAME #BASE,POINT2[] " ",TQ_STATE FALSE}
DECL LDAT LCPDAT53={VEL 2.00000,ACC 100.000,APO_DIST 100.000,APO_FAC 50.0000,AXIS_VEL 100.000,AXIS_ACC
100.000,ORI_TYP #JOINT,CIRC_TYP #BASE,JERK_FAC 50.0000,GEAR_JERK 50.0000,EXAX_IGN 0}
DECL E6POS XP55={X -914.327271,Y -472.865723,Z 357.132629,A 166.658844,B 61.5673141,C -7.03622961,S 2,T 10,E1 0.0,E2 0.0,E3
0.0,E4 0.0,E5 0.0,E6 0.0}
DECL FDAT FP55={TOOL_NO 10,BASE_NO 14,IPO_FRAME #BASE,POINT2[] " ",TQ_STATE FALSE}
DECL LDAT LCPDAT54={VEL 2.00000,ACC 100.000,APO_DIST 100.000,APO_FAC 50.0000,AXIS_VEL 100.000,AXIS_ACC
100.000,ORI_TYP #JOINT,CIRC_TYP #BASE,JERK_FAC 50.0000,GEAR_JERK 50.0000,EXAX_IGN 0}
DECL E6POS XP56={X -921.805176,Y -385.854797,Z 372.330231,A 166.658401,B 61.5680771,C -17.7946377,S 2,T 10,E1 0.0,E2 0.0,E3
0.0,E4 0.0,E5 0.0,E6 0.0}
DECL FDAT FP56={TOOL_NO 10,BASE_NO 14,IPO_FRAME #BASE,POINT2[] " ",TQ_STATE FALSE}

```

```

DECL LDAT LCPDAT55={VEL 2.00000,ACC 100.000,APO_DIST 100.000,APO_FAC 50.0000,AXIS_VEL 100.000,AXIS_ACC
100.000,ORI_TYP #JOINT,CIRC_TYP #BASE,JERK_FAC 50.0000,GEAR_JERK 50.0000,EXAX_IGN 0}
DECL E6POS XP57={X -926.323,Y -377.446655,Z 370.175812,A 166.653610,B 61.5822868,C -35.1346817,S 2,T 10,E1 0.0,E2 0.0,E3
0.0,E4 0.0,E5 0.0,E6 0.0}
DECL FDAT FP57={TOOL_NO 10,BASE_NO 14,IPO_FRAME #BASE,POINT2[] " ",TQ_STATE FALSE}
DECL LDAT LCPDAT56={VEL 2.00000,ACC 100.000,APO_DIST 100.000,APO_FAC 50.0000,AXIS_VEL 100.000,AXIS_ACC
100.000,ORI_TYP #JOINT,CIRC_TYP #BASE,JERK_FAC 50.0000,GEAR_JERK 50.0000,EXAX_IGN 0}
DECL E6POS XP58={X -935.662048,Y -367.910614,Z 368.573486,A 166.658401,B 61.5680771,C -17.7946377,S 2,T 10,E1 0.0,E2 0.0,E3
0.0,E4 0.0,E5 0.0,E6 0.0}
DECL FDAT FP58={TOOL_NO 10,BASE_NO 14,IPO_FRAME #BASE,POINT2[] " ",TQ_STATE FALSE}
DECL LDAT LCPDAT57={VEL 2.00000,ACC 100.000,APO_DIST 100.000,APO_FAC 50.0000,AXIS_VEL 100.000,AXIS_ACC
100.000,ORI_TYP #JOINT,CIRC_TYP #BASE,JERK_FAC 50.0000,GEAR_JERK 50.0000,EXAX_IGN 0}
DECL E6POS XP59={X -937.263306,Y -367.932953,Z 369.304962,A 166.056412,B 62.4676743,C -16.8437119,S 2,T 10,E1 0.0,E2 0.0,E3
0.0,E4 0.0,E5 0.0,E6 0.0}
DECL FDAT FP59={TOOL_NO 10,BASE_NO 14,IPO_FRAME #BASE,POINT2[] " ",TQ_STATE FALSE}
DECL LDAT LCPDAT58={VEL 2.00000,ACC 100.000,APO_DIST 100.000,APO_FAC 50.0000,AXIS_VEL 100.000,AXIS_ACC
100.000,ORI_TYP #JOINT,CIRC_TYP #BASE,JERK_FAC 50.0000,GEAR_JERK 50.0000,EXAX_IGN 0}
DECL E6POS XP60={X -933.149109,Y -367.544983,Z 367.270752,A 166.040024,B 62.4953,C -15.3251467,S 2,T 10,E1 0.0,E2 0.0,E3
0.0,E4 0.0,E5 0.0,E6 0.0}
DECL FDAT FP60={TOOL_NO 10,BASE_NO 14,IPO_FRAME #BASE,POINT2[] " ",TQ_STATE FALSE}
DECL LDAT LCPDAT59={VEL 2.00000,ACC 100.000,APO_DIST 100.000,APO_FAC 50.0000,AXIS_VEL 100.000,AXIS_ACC
100.000,ORI_TYP #JOINT,CIRC_TYP #BASE,JERK_FAC 50.0000,GEAR_JERK 50.0000,EXAX_IGN 0}
DECL E6POS XP61={X -928.352844,Y -367.276062,Z 364.881,A 166.227600,B 62.1616,C -14.3161697,S 2,T 10,E1 0.0,E2 0.0,E3 0.0,E4
0.0,E5 0.0,E6 0.0}
DECL FDAT FP61={TOOL_NO 10,BASE_NO 14,IPO_FRAME #BASE,POINT2[] " ",TQ_STATE FALSE}
DECL LDAT LCPDAT60={VEL 2.00000,ACC 100.000,APO_DIST 100.000,APO_FAC 50.0000,AXIS_VEL 100.000,AXIS_ACC
100.000,ORI_TYP #JOINT,CIRC_TYP #BASE,JERK_FAC 50.0000,GEAR_JERK 50.0000,EXAX_IGN 0}
DECL E6POS XP62={X -922.844482,Y -367.052338,Z 362.083862,A 166.413162,B 61.8059311,C -13.4832039,S 2,T 10,E1 0.0,E2 0.0,E3
0.0,E4 0.0,E5 0.0,E6 0.0}
DECL FDAT FP62={TOOL_NO 10,BASE_NO 14,IPO_FRAME #BASE,POINT2[] " ",TQ_STATE FALSE}
DECL LDAT LCPDAT61={VEL 2.00000,ACC 100.000,APO_DIST 100.000,APO_FAC 50.0000,AXIS_VEL 100.000,AXIS_ACC
100.000,ORI_TYP #JOINT,CIRC_TYP #BASE,JERK_FAC 50.0000,GEAR_JERK 50.0000,EXAX_IGN 0}
DECL E6POS XP63={X -909.623535,Y -366.675659,Z 355.242401,A 166.833435,B 60.9206467,C -12.1215773,S 2,T 10,E1 0.0,E2 0.0,E3
0.0,E4 0.0,E5 0.0,E6 0.0}
DECL FDAT FP63={TOOL_NO 10,BASE_NO 14,IPO_FRAME #BASE,POINT2[] " ",TQ_STATE FALSE}
DECL LDAT LCPDAT62={VEL 2.00000,ACC 100.000,APO_DIST 100.000,APO_FAC 50.0000,AXIS_VEL 100.000,AXIS_ACC
100.000,ORI_TYP #JOINT,CIRC_TYP #BASE,JERK_FAC 50.0000,GEAR_JERK 50.0000,EXAX_IGN 0}
DECL E6POS XP64={X -903.087097,Y -366.624664,Z 351.709412,A 166.833435,B 60.9206390,C -11.1980677,S 2,T 10,E1 0.0,E2 0.0,E3
0.0,E4 0.0,E5 0.0,E6 0.0}
DECL FDAT FP64={TOOL_NO 10,BASE_NO 14,IPO_FRAME #BASE,POINT2[] " ",TQ_STATE FALSE}
DECL LDAT LCPDAT63={VEL 2.00000,ACC 100.000,APO_DIST 100.000,APO_FAC 50.0000,AXIS_VEL 100.000,AXIS_ACC
100.000,ORI_TYP #JOINT,CIRC_TYP #BASE,JERK_FAC 50.0000,GEAR_JERK 50.0000,EXAX_IGN 0}
DECL E6POS XP65={X -899.816101,Y -366.688477,Z 349.898804,A 166.847809,B 60.9281540,C 8.75790691,S 2,T 10,E1 0.0,E2 0.0,E3
0.0,E4 0.0,E5 0.0,E6 0.0}
DECL FDAT FP65={TOOL_NO 10,BASE_NO 14,IPO_FRAME #BASE,POINT2[] " ",TQ_STATE FALSE}
DECL LDAT LCPDAT64={VEL 2.00000,ACC 100.000,APO_DIST 100.000,APO_FAC 50.0000,AXIS_VEL 100.000,AXIS_ACC
100.000,ORI_TYP #JOINT,CIRC_TYP #BASE,JERK_FAC 50.0000,GEAR_JERK 50.0000,EXAX_IGN 0}
DECL E6POS XP66={X -894.505493,Y -366.777893,Z 347.236450,A 165.978287,B 62.4854240,C -11.2357483,S 2,T 10,E1 0.0,E2 0.0,E3
0.0,E4 0.0,E5 0.0,E6 0.0}
DECL FDAT FP66={TOOL_NO 10,BASE_NO 14,IPO_FRAME #BASE,POINT2[] " ",TQ_STATE FALSE}
DECL LDAT LCPDAT65={VEL 2.00000,ACC 100.000,APO_DIST 100.000,APO_FAC 50.0000,AXIS_VEL 100.000,AXIS_ACC
100.000,ORI_TYP #JOINT,CIRC_TYP #BASE,JERK_FAC 50.0000,GEAR_JERK 50.0000,EXAX_IGN 0}
DECL E6POS XP67={X -894.740540,Y -443.669861,Z 339.828644,A 166.047333,B 62.3385429,C -2.86851907,S 2,T 10,E1 0.0,E2 0.0,E3
0.0,E4 0.0,E5 0.0,E6 0.0}
DECL FDAT FP67={TOOL_NO 10,BASE_NO 14,IPO_FRAME #BASE,POINT2[] " ",TQ_STATE FALSE}
DECL LDAT LCPDAT66={VEL 2.00000,ACC 100.000,APO_DIST 100.000,APO_FAC 50.0000,AXIS_VEL 100.000,AXIS_ACC
100.000,ORI_TYP #JOINT,CIRC_TYP #BASE,JERK_FAC 50.0000,GEAR_JERK 50.0000,EXAX_IGN 0}
DECL E6POS XP68={X -903.617,Y -442.111450,Z 344.470947,A 165.753098,B 62.7839203,C -3.81230426,S 2,T 10,E1 0.0,E2 0.0,E3
0.0,E4 0.0,E5 0.0,E6 0.0}
DECL FDAT FP68={TOOL_NO 10,BASE_NO 14,IPO_FRAME #BASE,POINT2[] " ",TQ_STATE FALSE}
DECL LDAT LCPDAT67={VEL 2.00000,ACC 100.000,APO_DIST 100.000,APO_FAC 50.0000,AXIS_VEL 100.000,AXIS_ACC
100.000,ORI_TYP #JOINT,CIRC_TYP #BASE,JERK_FAC 50.0000,GEAR_JERK 50.0000,EXAX_IGN 0}
DECL E6POS XP69={X -911.758057,Y -440.802032,Z 348.616364,A 165.679199,B 63.2153282,C -4.63014269,S 2,T 10,E1 0.0,E2 0.0,E3
0.0,E4 0.0,E5 0.0,E6 0.0}
DECL FDAT FP69={TOOL_NO 10,BASE_NO 14,IPO_FRAME #BASE,POINT2[] " ",TQ_STATE FALSE}
DECL LDAT LCPDAT68={VEL 2.00000,ACC 100.000,APO_DIST 100.000,APO_FAC 50.0000,AXIS_VEL 100.000,AXIS_ACC
100.000,ORI_TYP #JOINT,CIRC_TYP #BASE,JERK_FAC 50.0000,GEAR_JERK 50.0000,EXAX_IGN 0}
DECL E6POS XP70={X -923.585144,Y -439.274536,Z 354.396606,A 165.502747,B 63.9650650,C -6.42019367,S 2,T 10,E1 0.0,E2 0.0,E3
0.0,E4 0.0,E5 0.0,E6 0.0}
DECL FDAT FP70={TOOL_NO 10,BASE_NO 14,IPO_FRAME #BASE,POINT2[] " ",TQ_STATE FALSE}
DECL LDAT LCPDAT69={VEL 2.00000,ACC 100.000,APO_DIST 100.000,APO_FAC 50.0000,AXIS_VEL 100.000,AXIS_ACC
100.000,ORI_TYP #JOINT,CIRC_TYP #BASE,JERK_FAC 50.0000,GEAR_JERK 50.0000,EXAX_IGN 0}
DECL E6POS XP71={X -929.551575,Y -438.726349,Z 357.265167,A 165.423798,B 64.1995468,C -8.40540504,S 2,T 10,E1 0.0,E2 0.0,E3
0.0,E4 0.0,E5 0.0,E6 0.0}
DECL FDAT FP71={TOOL_NO 10,BASE_NO 14,IPO_FRAME #BASE,POINT2[] " ",TQ_STATE FALSE}

```

DECL LDAT LCPDAT70={VEL 2.00000,ACC 100.000,APO_DIST 100.000,APO_FAC 50.0000,AXIS_VEL 100.000,AXIS_ACC 100.000,ORI_TYP #JOINT,CIRC_TYP #BASE,JERK_FAC 50.0000,GEAR_JERK 50.0000,EXAX_IGN 0}
DECL E6POS XP72={X -928.773499,Y -439.028259,Z 356.932190,A 165.615356,B 63.7273026,C -10.0105391,S 2,T 10,E1 0.0,E2 0.0,E3 0.0,E4 0.0,E5 0.0,E6 0.0}
DECL FDAT FP72={TOOL_NO 10,BASE_NO 14,IPO_FRAME #BASE,POINT2[] " ",TQ_STATE FALSE}
DECL LDAT LCPDAT71={VEL 2.00000,ACC 100.000,APO_DIST 100.000,APO_FAC 50.0000,AXIS_VEL 100.000,AXIS_ACC 100.000,ORI_TYP #JOINT,CIRC_TYP #BASE,JERK_FAC 50.0000,GEAR_JERK 50.0000,EXAX_IGN 0}
DECL E6POS XP73={X -920.238525,Y -401.738464,Z 358.005676,A 166.137894,B 62.7534447,C -15.5951395,S 2,T 10,E1 0.0,E2 0.0,E3 0.0,E4 0.0,E5 0.0,E6 0.0}
DECL FDAT FP73={TOOL_NO 10,BASE_NO 14,IPO_FRAME #BASE,POINT2[] " ",TQ_STATE FALSE}
DECL LDAT LCPDAT72={VEL 2.00000,ACC 100.000,APO_DIST 100.000,APO_FAC 50.0000,AXIS_VEL 100.000,AXIS_ACC 100.000,ORI_TYP #JOINT,CIRC_TYP #BASE,JERK_FAC 50.0000,GEAR_JERK 50.0000,EXAX_IGN 0}
DECL E6POS XP74={X -938.279968,Y -319.244202,Z 377.404358,A 166.885986,B 62.0442963,C -25.6979122,S 2,T 10,E1 0.0,E2 0.0,E3 0.0,E4 0.0,E5 0.0,E6 0.0}
DECL FDAT FP74={TOOL_NO 10,BASE_NO 14,IPO_FRAME #BASE,POINT2[] " ",TQ_STATE FALSE}
DECL LDAT LCPDAT73={VEL 2.00000,ACC 100.000,APO_DIST 100.000,APO_FAC 50.0000,AXIS_VEL 100.000,AXIS_ACC 100.000,ORI_TYP #JOINT,CIRC_TYP #BASE,JERK_FAC 50.0000,GEAR_JERK 50.0000,EXAX_IGN 0}
DECL E6POS XP75={X -935.098938,Y -319.223785,Z 379.948639,A 167.348801,B 61.6055031,C -26.9532013,S 2,T 10,E1 0.0,E2 0.0,E3 0.0,E4 0.0,E5 0.0,E6 0.0}
DECL FDAT FP75={TOOL_NO 10,BASE_NO 14,IPO_FRAME #BASE,POINT2[] " ",TQ_STATE FALSE}
DECL LDAT LCPDAT74={VEL 2.00000,ACC 100.000,APO_DIST 100.000,APO_FAC 50.0000,AXIS_VEL 100.000,AXIS_ACC 100.000,ORI_TYP #JOINT,CIRC_TYP #BASE,JERK_FAC 50.0000,GEAR_JERK 50.0000,EXAX_IGN 0}
DECL E6POS XP76={X -923.885742,Y -311.857086,Z 375.103058,A 166.780670,B 61.6296654,C -48.5415611,S 2,T 10,E1 0.0,E2 0.0,E3 0.0,E4 0.0,E5 0.0,E6 0.0}
DECL FDAT FP76={TOOL_NO 10,BASE_NO 14,IPO_FRAME #BASE,POINT2[] " ",TQ_STATE FALSE}
DECL LDAT LCPDAT75={VEL 2.00000,ACC 100.000,APO_DIST 100.000,APO_FAC 50.0000,AXIS_VEL 100.000,AXIS_ACC 100.000,ORI_TYP #JOINT,CIRC_TYP #BASE,JERK_FAC 50.0000,GEAR_JERK 50.0000,EXAX_IGN 0}
DECL E6POS XP77={X -935.643372,Y -303.715088,Z 381.955811,A 165.395264,B 63.0575294,C -30.0980797,S 2,T 10,E1 0.0,E2 0.0,E3 0.0,E4 0.0,E5 0.0,E6 0.0}
DECL FDAT FP77={TOOL_NO 10,BASE_NO 14,IPO_FRAME #BASE,POINT2[] " ",TQ_STATE FALSE}
DECL LDAT LCPDAT76={VEL 2.00000,ACC 100.000,APO_DIST 100.000,APO_FAC 50.0000,AXIS_VEL 100.000,AXIS_ACC 100.000,ORI_TYP #JOINT,CIRC_TYP #BASE,JERK_FAC 50.0000,GEAR_JERK 50.0000,EXAX_IGN 0}
DECL E6POS XP78={X -936.367371,Y -303.953278,Z 382.279358,A 165.357803,B 63.1915207,C -29.9563293,S 2,T 10,E1 0.0,E2 0.0,E3 0.0,E4 0.0,E5 0.0,E6 0.0}
DECL FDAT FP78={TOOL_NO 10,BASE_NO 14,IPO_FRAME #BASE,POINT2[] " ",TQ_STATE FALSE}
DECL LDAT LCPDAT77={VEL 2.00000,ACC 100.000,APO_DIST 100.000,APO_FAC 50.0000,AXIS_VEL 100.000,AXIS_ACC 100.000,ORI_TYP #JOINT,CIRC_TYP #BASE,JERK_FAC 50.0000,GEAR_JERK 50.0000,EXAX_IGN 0}
DECL E6POS XP79={X -943.285461,Y -306.053711,Z 385.298615,A 164.475128,B 63.8937340,C -29.6458397,S 2,T 10,E1 0.0,E2 0.0,E3 0.0,E4 0.0,E5 0.0,E6 0.0}
DECL FDAT FP79={TOOL_NO 10,BASE_NO 14,IPO_FRAME #BASE,POINT2[] " ",TQ_STATE FALSE}
DECL LDAT LCPDAT78={VEL 2.00000,ACC 100.000,APO_DIST 100.000,APO_FAC 50.0000,AXIS_VEL 100.000,AXIS_ACC 100.000,ORI_TYP #JOINT,CIRC_TYP #BASE,JERK_FAC 50.0000,GEAR_JERK 50.0000,EXAX_IGN 0}
DECL E6POS XP80={X -949.519958,Y -307.775757,Z 387.925934,A 163.463226,B 64.6843719,C -29.3839226,S 2,T 10,E1 0.0,E2 0.0,E3 0.0,E4 0.0,E5 0.0,E6 0.0}
DECL FDAT FP80={TOOL_NO 10,BASE_NO 14,IPO_FRAME #BASE,POINT2[] " ",TQ_STATE FALSE}
DECL LDAT LCPDAT79={VEL 2.00000,ACC 100.000,APO_DIST 100.000,APO_FAC 50.0000,AXIS_VEL 100.000,AXIS_ACC 100.000,ORI_TYP #JOINT,CIRC_TYP #BASE,JERK_FAC 50.0000,GEAR_JERK 50.0000,EXAX_IGN 0}
DECL E6POS XP81={X -952.653870,Y -308.524658,Z 389.195618,A 162.507782,B 65.4530106,C -28.5706043,S 2,T 10,E1 0.0,E2 0.0,E3 0.0,E4 0.0,E5 0.0,E6 0.0}
DECL FDAT FP81={TOOL_NO 10,BASE_NO 14,IPO_FRAME #BASE,POINT2[] " ",TQ_STATE FALSE}
DECL LDAT LCPDAT80={VEL 2.00000,ACC 100.000,APO_DIST 100.000,APO_FAC 50.0000,AXIS_VEL 100.000,AXIS_ACC 100.000,ORI_TYP #JOINT,CIRC_TYP #BASE,JERK_FAC 50.0000,GEAR_JERK 50.0000,EXAX_IGN 0}
DECL E6POS XP82={X -951.316772,Y -308.231873,Z 388.655212,A 162.048660,B 65.8138275,C -27.7494984,S 2,T 10,E1 0.0,E2 0.0,E3 0.0,E4 0.0,E5 0.0,E6 0.0}
DECL FDAT FP82={TOOL_NO 10,BASE_NO 14,IPO_FRAME #BASE,POINT2[] " ",TQ_STATE FALSE}
DECL LDAT LCPDAT81={VEL 2.00000,ACC 100.000,APO_DIST 100.000,APO_FAC 50.0000,AXIS_VEL 100.000,AXIS_ACC 100.000,ORI_TYP #JOINT,CIRC_TYP #BASE,JERK_FAC 50.0000,GEAR_JERK 50.0000,EXAX_IGN 0}
DECL E6POS XP83={X -947.849060,Y -307.493347,Z 387.275818,A 161.735809,B 66.0612183,C -26.5698681,S 2,T 10,E1 0.0,E2 0.0,E3 0.0,E4 0.0,E5 0.0,E6 0.0}
DECL FDAT FP83={TOOL_NO 10,BASE_NO 14,IPO_FRAME #BASE,POINT2[] " ",TQ_STATE FALSE}
DECL LDAT LCPDAT82={VEL 2.00000,ACC 100.000,APO_DIST 100.000,APO_FAC 50.0000,AXIS_VEL 100.000,AXIS_ACC 100.000,ORI_TYP #JOINT,CIRC_TYP #BASE,JERK_FAC 50.0000,GEAR_JERK 50.0000,EXAX_IGN 0}
DECL E6POS XP84={X -928.541199,Y -383.845978,Z 368.493958,A 161.919754,B 65.8174820,C -16.1883125,S 2,T 10,E1 0.0,E2 0.0,E3 0.0,E4 0.0,E5 0.0,E6 0.0}
DECL FDAT FP84={TOOL_NO 10,BASE_NO 14,IPO_FRAME #BASE,POINT2[] " ",TQ_STATE FALSE}
DECL LDAT LCPDAT83={VEL 2.00000,ACC 100.000,APO_DIST 100.000,APO_FAC 50.0000,AXIS_VEL 100.000,AXIS_ACC 100.000,ORI_TYP #JOINT,CIRC_TYP #BASE,JERK_FAC 50.0000,GEAR_JERK 50.0000,EXAX_IGN 0}
DECL E6POS XP85={X -921.389771,Y -383.899353,Z 365.433716,A 161.919754,B 65.8174820,C -16.1883125,S 2,T 10,E1 0.0,E2 0.0,E3 0.0,E4 0.0,E5 0.0,E6 0.0}
DECL FDAT FP85={TOOL_NO 10,BASE_NO 14,IPO_FRAME #BASE,POINT2[] " ",TQ_STATE FALSE}
DECL LDAT LCPDAT84={VEL 2.00000,ACC 100.000,APO_DIST 100.000,APO_FAC 50.0000,AXIS_VEL 100.000,AXIS_ACC 100.000,ORI_TYP #JOINT,CIRC_TYP #BASE,JERK_FAC 50.0000,GEAR_JERK 50.0000,EXAX_IGN 0}
DECL E6POS XP86={X -915.947388,Y -383.939941,Z 363.104858,A 162.381638,B 65.1433487,C -15.3985682,S 2,T 10,E1 0.0,E2 0.0,E3 0.0,E4 0.0,E5 0.0,E6 0.0}
DECL FDAT FP86={TOOL_NO 10,BASE_NO 14,IPO_FRAME #BASE,POINT2[] " ",TQ_STATE FALSE}

DECL LDAT LCPDAT85={VEL 2.00000,ACC 100.000,APO_DIST 100.000,APO_FAC 50.0000,AXIS_VEL 100.000,AXIS_ACC 100.000,ORI_TYP #JOINT,CIRC_TYP #BASE,JERK_FAC 50.0000,GEAR_JERK 50.0000,EXAX_IGN 0}
DECL E6POS XP87={X -897.294800,Y -384.178680,Z 354.835602,A 163.088806,B 63.9763641,C -14.0898218,S 2,T 10,E1 0.0,E2 0.0,E3 0.0,E4 0.0,E5 0.0,E6 0.0}
DECL FDAT FP87={TOOL_NO 10,BASE_NO 14,IPO_FRAME #BASE,POINT2[] " ",TQ_STATE FALSE}
DECL LDAT LCPDAT86={VEL 2.00000,ACC 100.000,APO_DIST 100.000,APO_FAC 50.0000,AXIS_VEL 100.000,AXIS_ACC 100.000,ORI_TYP #JOINT,CIRC_TYP #BASE,JERK_FAC 50.0000,GEAR_JERK 50.0000,EXAX_IGN 0}
DECL E6POS XP88={X -892.995667,Y -384.276672,Z 352.813446,A 163.213531,B 63.7545357,C -13.7758236,S 2,T 10,E1 0.0,E2 0.0,E3 0.0,E4 0.0,E5 0.0,E6 0.0}
DECL FDAT FP88={TOOL_NO 10,BASE_NO 14,IPO_FRAME #BASE,POINT2[] " ",TQ_STATE FALSE}
DECL LDAT LCPDAT87={VEL 2.00000,ACC 100.000,APO_DIST 100.000,APO_FAC 50.0000,AXIS_VEL 100.000,AXIS_ACC 100.000,ORI_TYP #JOINT,CIRC_TYP #BASE,JERK_FAC 50.0000,GEAR_JERK 50.0000,EXAX_IGN 0}
DECL E6POS XP89={X -880.466492,Y -384.604248,Z 346.852570,A 163.360107,B 63.4839096,C -13.4134455,S 2,T 10,E1 0.0,E2 0.0,E3 0.0,E4 0.0,E5 0.0,E6 0.0}
DECL FDAT FP89={TOOL_NO 10,BASE_NO 14,IPO_FRAME #BASE,POINT2[] " ",TQ_STATE FALSE}
DECL LDAT LCPDAT88={VEL 2.00000,ACC 100.000,APO_DIST 100.000,APO_FAC 50.0000,AXIS_VEL 100.000,AXIS_ACC 100.000,ORI_TYP #JOINT,CIRC_TYP #BASE,JERK_FAC 50.0000,GEAR_JERK 50.0000,EXAX_IGN 0}
DECL E6POS XP90={X -880.405701,Y -384.649384,Z 346.776123,A 163.376236,B 63.4950676,C 1.60676587,S 2,T 10,E1 0.0,E2 0.0,E3 0.0,E4 0.0,E5 0.0,E6 0.0}
DECL FDAT FP90={TOOL_NO 10,BASE_NO 14,IPO_FRAME #BASE,POINT2[] " ",TQ_STATE FALSE}
DECL LDAT LCPDAT89={VEL 2.00000,ACC 100.000,APO_DIST 100.000,APO_FAC 50.0000,AXIS_VEL 100.000,AXIS_ACC 100.000,ORI_TYP #JOINT,CIRC_TYP #BASE,JERK_FAC 50.0000,GEAR_JERK 50.0000,EXAX_IGN 0}
DECL E6POS XP91={X -867.982727,Y -493.365662,Z 377.198853,A 168.327606,B 70.9995422,C 5.19034863,S 2,T 10,E1 0.0,E2 0.0,E3 0.0,E4 0.0,E5 0.0,E6 0.0}
DECL FDAT FP91={TOOL_NO 10,BASE_NO 14,IPO_FRAME #BASE,POINT2[] " ",TQ_STATE FALSE}
DECL LDAT LCPDAT90={VEL 2.00000,ACC 100.000,APO_DIST 100.000,APO_FAC 50.0000,AXIS_VEL 100.000,AXIS_ACC 100.000,ORI_TYP #JOINT,CIRC_TYP #BASE,JERK_FAC 50.0000,GEAR_JERK 50.0000,EXAX_IGN 0}
DECL E6POS XP92={X -869.434509,Y -492.948334,Z 377.703491,A 168.440247,B 71.4755096,C 4.24569368,S 2,T 10,E1 0.0,E2 0.0,E3 0.0,E4 0.0,E5 0.0,E6 0.0}
DECL FDAT FP92={TOOL_NO 10,BASE_NO 14,IPO_FRAME #BASE,POINT2[] " ",TQ_STATE FALSE}
DECL LDAT LCPDAT91={VEL 2.00000,ACC 100.000,APO_DIST 100.000,APO_FAC 50.0000,AXIS_VEL 100.000,AXIS_ACC 100.000,ORI_TYP #JOINT,CIRC_TYP #BASE,JERK_FAC 50.0000,GEAR_JERK 50.0000,EXAX_IGN 0}
DECL E6POS XP93={X -883.134094,Y -489.184418,Z 382.300812,A 168.553391,B 72.0296478,C 3.72553706,S 2,T 10,E1 0.0,E2 0.0,E3 0.0,E4 0.0,E5 0.0,E6 0.0}
DECL FDAT FP93={TOOL_NO 10,BASE_NO 14,IPO_FRAME #BASE,POINT2[] " ",TQ_STATE FALSE}
DECL LDAT LCPDAT92={VEL 2.00000,ACC 100.000,APO_DIST 100.000,APO_FAC 50.0000,AXIS_VEL 100.000,AXIS_ACC 100.000,ORI_TYP #JOINT,CIRC_TYP #BASE,JERK_FAC 50.0000,GEAR_JERK 50.0000,EXAX_IGN 0}
DECL E6POS XP94={X -895.463,Y -485.970459,Z 386.291656,A 168.660,B 72.6508789,C 3.03195,S 2,T 10,E1 0.0,E2 0.0,E3 0.0,E4 0.0,E5 0.0,E6 0.0}
DECL FDAT FP94={TOOL_NO 10,BASE_NO 14,IPO_FRAME #BASE,POINT2[] " ",TQ_STATE FALSE}
DECL LDAT LCPDAT93={VEL 2.00000,ACC 100.000,APO_DIST 100.000,APO_FAC 50.0000,AXIS_VEL 100.000,AXIS_ACC 100.000,ORI_TYP #JOINT,CIRC_TYP #BASE,JERK_FAC 50.0000,GEAR_JERK 50.0000,EXAX_IGN 0}
DECL E6POS XP95={X -905.794189,Y -483.480865,Z 389.521820,A 168.738,B 73.2352,C 2.18737984,S 2,T 10,E1 0.0,E2 0.0,E3 0.0,E4 0.0,E5 0.0,E6 0.0}
DECL FDAT FP95={TOOL_NO 10,BASE_NO 14,IPO_FRAME #BASE,POINT2[] " ",TQ_STATE FALSE}
DECL LDAT LCPDAT94={VEL 2.00000,ACC 100.000,APO_DIST 100.000,APO_FAC 50.0000,AXIS_VEL 100.000,AXIS_ACC 100.000,ORI_TYP #JOINT,CIRC_TYP #BASE,JERK_FAC 50.0000,GEAR_JERK 50.0000,EXAX_IGN 0}
DECL E6POS XP96={X -911.911316,Y -482.172607,Z 391.368225,A 168.759796,B 73.6687241,C 0.797182322,S 2,T 10,E1 0.0,E2 0.0,E3 0.0,E4 0.0,E5 0.0,E6 0.0}
DECL FDAT FP96={TOOL_NO 10,BASE_NO 14,IPO_FRAME #BASE,POINT2[] " ",TQ_STATE FALSE}
DECL LDAT LCPDAT95={VEL 2.00000,ACC 100.000,APO_DIST 100.000,APO_FAC 50.0000,AXIS_VEL 100.000,AXIS_ACC 100.000,ORI_TYP #JOINT,CIRC_TYP #BASE,JERK_FAC 50.0000,GEAR_JERK 50.0000,EXAX_IGN 0}
DECL E6POS XP97={X -911.052185,Y -482.463593,Z 391.115814,A 168.761,B 73.5679245,C -0.193439052,S 2,T 10,E1 0.0,E2 0.0,E3 0.0,E4 0.0,E5 0.0,E6 0.0}
DECL FDAT FP97={TOOL_NO 10,BASE_NO 14,IPO_FRAME #BASE,POINT2[] " ",TQ_STATE FALSE}
DECL LDAT LCPDAT96={VEL 2.00000,ACC 100.000,APO_DIST 100.000,APO_FAC 50.0000,AXIS_VEL 100.000,AXIS_ACC 100.000,ORI_TYP #JOINT,CIRC_TYP #BASE,JERK_FAC 50.0000,GEAR_JERK 50.0000,EXAX_IGN 0}
DECL E6POS XP98={X -914.315857,Y -394.508148,Z 397.111450,A 169.304276,B 72.9226837,C -12.8950024,S 2,T 10,E1 0.0,E2 0.0,E3 0.0,E4 0.0,E5 0.0,E6 0.0}
DECL FDAT FP98={TOOL_NO 10,BASE_NO 14,IPO_FRAME #BASE,POINT2[] " ",TQ_STATE FALSE}
DECL LDAT LCPDAT97={VEL 2.00000,ACC 100.000,APO_DIST 100.000,APO_FAC 50.0000,AXIS_VEL 100.000,AXIS_ACC 100.000,ORI_TYP #JOINT,CIRC_TYP #BASE,JERK_FAC 50.0000,GEAR_JERK 50.0000,EXAX_IGN 0}
DECL E6POS XP99={X -916.215820,Y -394.548859,Z 397.667633,A 169.022568,B 73.3316040,C -11.7071142,S 2,T 10,E1 0.0,E2 0.0,E3 0.0,E4 0.0,E5 0.0,E6 0.0}
DECL FDAT FP99={TOOL_NO 10,BASE_NO 14,IPO_FRAME #BASE,POINT2[] " ",TQ_STATE FALSE}
DECL LDAT LCPDAT98={VEL 2.00000,ACC 100.000,APO_DIST 100.000,APO_FAC 50.0000,AXIS_VEL 100.000,AXIS_ACC 100.000,ORI_TYP #JOINT,CIRC_TYP #BASE,JERK_FAC 50.0000,GEAR_JERK 50.0000,EXAX_IGN 0}
DECL E6POS XP100={X -911.824,Y -394.594360,Z 396.405731,A 169.419769,B 72.8362808,C -13.6565037,S 2,T 10,E1 0.0,E2 0.0,E3 0.0,E4 0.0,E5 0.0,E6 0.0}
DECL FDAT FP100={TOOL_NO 10,BASE_NO 14,IPO_FRAME #BASE,POINT2[] " ",TQ_STATE FALSE}
DECL LDAT LCPDAT99={VEL 2.00000,ACC 100.000,APO_DIST 100.000,APO_FAC 50.0000,AXIS_VEL 100.000,AXIS_ACC 100.000,ORI_TYP #JOINT,CIRC_TYP #BASE,JERK_FAC 50.0000,GEAR_JERK 50.0000,EXAX_IGN 0}
DECL E6POS XP101={X -902.002869,Y -393.961426,Z 393.459930,A 170.054031,B 72.0875702,C -14.6185331,S 2,T 10,E1 0.0,E2 0.0,E3 0.0,E4 0.0,E5 0.0,E6 0.0}
DECL FDAT FP101={TOOL_NO 10,BASE_NO 14,IPO_FRAME #BASE,POINT2[] " ",TQ_STATE FALSE}

```

DECL LDAT LCPDAT100={VEL 2.00000,ACC 100.000,APO_DIST 100.000,APO_FAC 50.0000,AXIS_VEL 100.000,AXIS_ACC
100.000,ORI_TYP #JOINT,CIRC_TYP #BASE,JERK_FAC 50.0000,GEAR_JERK 50.0000,EXAX_IGN 0}
DECL E6POS XP102={X -891.132813,Y -392.937134,Z 390.056396,A 170.706757,B 71.3135834,C -14.9508991,S 2,T 10,E1 0.0,E2 0.0,E3
0.0,E4 0.0,E5 0.0,E6 0.0}
DECL FDAT FP102={TOOL_NO 10,BASE_NO 14,IPO_FRAME #BASE,POINT2[] " ",TQ_STATE FALSE}
DECL LDAT LCPDAT101={VEL 2.00000,ACC 100.000,APO_DIST 100.000,APO_FAC 50.0000,AXIS_VEL 100.000,AXIS_ACC
100.000,ORI_TYP #JOINT,CIRC_TYP #BASE,JERK_FAC 50.0000,GEAR_JERK 50.0000,EXAX_IGN 0}
DECL E6POS XP103={X -886.418945,Y -392.420227,Z 388.453522,A 170.976456,B 71.0377808,C -27.5072594,S 2,T 10,E1 0.0,E2 0.0,E3
0.0,E4 0.0,E5 0.0,E6 0.0}
DECL FDAT FP103={TOOL_NO 10,BASE_NO 14,IPO_FRAME #BASE,POINT2[] " ",TQ_STATE FALSE}
DECL LDAT LCPDAT102={VEL 2.00000,ACC 100.000,APO_DIST 100.000,APO_FAC 50.0000,AXIS_VEL 100.000,AXIS_ACC
100.000,ORI_TYP #JOINT,CIRC_TYP #BASE,JERK_FAC 50.0000,GEAR_JERK 50.0000,EXAX_IGN 0}
DECL E6POS XP104={X -902.503723,Y -295.027039,Z 432.355133,A 163.316406,B 75.1282959,C -35.3239784,S 2,T 10,E1 0.0,E2 0.0,E3
0.0,E4 0.0,E5 0.0,E6 0.0}
DECL FDAT FP104={TOOL_NO 10,BASE_NO 14,IPO_FRAME #BASE,POINT2[] " ",TQ_STATE FALSE}
DECL LDAT LCPDAT103={VEL 2.00000,ACC 100.000,APO_DIST 100.000,APO_FAC 50.0000,AXIS_VEL 100.000,AXIS_ACC
100.000,ORI_TYP #JOINT,CIRC_TYP #BASE,JERK_FAC 50.0000,GEAR_JERK 50.0000,EXAX_IGN 0}
DECL E6POS XP105={X -925.250793,Y -279.649536,Z 439.096497,A 161.240784,B 75.8160629,C -39.1217918,S 2,T 10,E1 0.0,E2 0.0,E3
0.0,E4 0.0,E5 0.0,E6 0.0}
DECL FDAT FP105={TOOL_NO 10,BASE_NO 14,IPO_FRAME #BASE,POINT2[] " ",TQ_STATE FALSE}
DECL LDAT LCPDAT104={VEL 2.00000,ACC 100.000,APO_DIST 100.000,APO_FAC 50.0000,AXIS_VEL 100.000,AXIS_ACC
100.000,ORI_TYP #JOINT,CIRC_TYP #BASE,JERK_FAC 50.0000,GEAR_JERK 50.0000,EXAX_IGN 0}
DECL E6POS XP106={X -936.281,Y -270.615967,Z 442.438568,A 160.627121,B 75.9972610,C -40.3852844,S 2,T 10,E1 0.0,E2 0.0,E3
0.0,E4 0.0,E5 0.0,E6 0.0}
DECL FDAT FP106={TOOL_NO 10,BASE_NO 14,IPO_FRAME #BASE,POINT2[] " ",TQ_STATE FALSE}
DECL LDAT LCPDAT105={VEL 2.00000,ACC 100.000,APO_DIST 100.000,APO_FAC 50.0000,AXIS_VEL 100.000,AXIS_ACC
100.000,ORI_TYP #JOINT,CIRC_TYP #BASE,JERK_FAC 50.0000,GEAR_JERK 50.0000,EXAX_IGN 0}
DECL E6POS XP107={X -943.601685,Y -273.299622,Z 443.869049,A 158.917984,B 76.4892,C -40.3956108,S 2,T 10,E1 0.0,E2 0.0,E3
0.0,E4 0.0,E5 0.0,E6 0.0}
DECL FDAT FP107={TOOL_NO 10,BASE_NO 14,IPO_FRAME #BASE,POINT2[] " ",TQ_STATE FALSE}
DECL LDAT LCPDAT106={VEL 2.00000,ACC 100.000,APO_DIST 100.000,APO_FAC 50.0000,AXIS_VEL 100.000,AXIS_ACC
100.000,ORI_TYP #JOINT,CIRC_TYP #BASE,JERK_FAC 50.0000,GEAR_JERK 50.0000,EXAX_IGN 0}
DECL E6POS XP108={X -944.883423,Y -273.706665,Z 444.103424,A 156.891937,B 77.0498428,C -39.9975281,S 2,T 10,E1 0.0,E2 0.0,E3
0.0,E4 0.0,E5 0.0,E6 0.0}
DECL FDAT FP108={TOOL_NO 10,BASE_NO 14,IPO_FRAME #BASE,POINT2[] " ",TQ_STATE FALSE}
DECL LDAT LCPDAT107={VEL 2.00000,ACC 100.000,APO_DIST 100.000,APO_FAC 50.0000,AXIS_VEL 100.000,AXIS_ACC
100.000,ORI_TYP #JOINT,CIRC_TYP #BASE,JERK_FAC 50.0000,GEAR_JERK 50.0000,EXAX_IGN 0}
DECL E6POS XP109={X -920.188,Y -319.854828,Z 465.199768,A 160.773514,B 82.7231369,C -29.3439236,S 2,T 10,E1 0.0,E2 0.0,E3
0.0,E4 0.0,E5 0.0,E6 0.0}
DECL FDAT FP109={TOOL_NO 10,BASE_NO 14,IPO_FRAME #BASE,POINT2[] " ",TQ_STATE FALSE}
DECL LDAT LCPDAT108={VEL 2.00000,ACC 100.000,APO_DIST 100.000,APO_FAC 50.0000,AXIS_VEL 100.000,AXIS_ACC
100.000,ORI_TYP #JOINT,CIRC_TYP #BASE,JERK_FAC 50.0000,GEAR_JERK 50.0000,EXAX_IGN 0}
DECL E6POS XP110={X -918.448364,Y -323.696198,Z 464.828491,A 160.773514,B 82.7231369,C -29.3439198,S 2,T 10,E1 0.0,E2 0.0,E3
0.0,E4 0.0,E5 0.0,E6 0.0}
DECL FDAT FP110={TOOL_NO 10,BASE_NO 14,IPO_FRAME #BASE,POINT2[] " ",TQ_STATE FALSE}
DECL LDAT LCPDAT109={VEL 2.00000,ACC 100.000,APO_DIST 100.000,APO_FAC 50.0000,AXIS_VEL 100.000,AXIS_ACC
100.000,ORI_TYP #JOINT,CIRC_TYP #BASE,JERK_FAC 50.0000,GEAR_JERK 50.0000,EXAX_IGN 0}
DECL E6POS XP111={X -918.448364,Y -323.696198,Z 464.828491,A 160.773514,B 82.7231369,C -28.6917439,S 2,T 10,E1 0.0,E2 0.0,E3
0.0,E4 0.0,E5 0.0,E6 0.0}
DECL FDAT FP111={TOOL_NO 10,BASE_NO 14,IPO_FRAME #BASE,POINT2[] " ",TQ_STATE FALSE}
DECL LDAT LCPDAT110={VEL 2.00000,ACC 100.000,APO_DIST 100.000,APO_FAC 50.0000,AXIS_VEL 100.000,AXIS_ACC
100.000,ORI_TYP #JOINT,CIRC_TYP #BASE,JERK_FAC 50.0000,GEAR_JERK 50.0000,EXAX_IGN 0}
DECL E6POS XP112={X -917.705078,Y -323.501678,Z 464.744385,A 160.522125,B 82.7852,C -27.1859150,S 2,T 10,E1 0.0,E2 0.0,E3
0.0,E4 0.0,E5 0.0,E6 0.0}
DECL FDAT FP112={TOOL_NO 10,BASE_NO 14,IPO_FRAME #BASE,POINT2[] " ",TQ_STATE FALSE}
DECL LDAT LCPDAT111={VEL 2.00000,ACC 100.000,APO_DIST 100.000,APO_FAC 50.0000,AXIS_VEL 100.000,AXIS_ACC
100.000,ORI_TYP #JOINT,CIRC_TYP #BASE,JERK_FAC 50.0000,GEAR_JERK 50.0000,EXAX_IGN 0}
DECL E6POS XP113={X -893.213135,Y -556.903076,Z 451.648315,A 160.957199,B 82.8001785,C -0.493352234,S 2,T 10,E1 0.0,E2
0.0,E3 0.0,E4 0.0,E5 0.0,E6 0.0}
DECL FDAT FP113={TOOL_NO 10,BASE_NO 14,IPO_FRAME #BASE,POINT2[] " ",TQ_STATE FALSE}
DECL LDAT LCPDAT112={VEL 2.00000,ACC 100.000,APO_DIST 100.000,APO_FAC 50.0000,AXIS_VEL 100.000,AXIS_ACC
100.000,ORI_TYP #JOINT,CIRC_TYP #BASE,JERK_FAC 50.0000,GEAR_JERK 50.0000,EXAX_IGN 0}
DECL E6POS XP114={X -912.706665,Y -340.851593,Z 463.414917,A 160.773529,B 82.7231293,C -26.0660305,S 2,T 10,E1 0.0,E2 0.0,E3
0.0,E4 0.0,E5 0.0,E6 0.0}
DECL FDAT FP114={TOOL_NO 10,BASE_NO 14,IPO_FRAME #BASE,POINT2[] " ",TQ_STATE FALSE}
DECL LDAT LCPDAT113={VEL 2.00000,ACC 100.000,APO_DIST 100.000,APO_FAC 50.0000,AXIS_VEL 100.000,AXIS_ACC
100.000,ORI_TYP #JOINT,CIRC_TYP #BASE,JERK_FAC 50.0000,GEAR_JERK 50.0000,EXAX_IGN 0}
DECL E6POS XP115={X -909.243042,Y -352.247345,Z 462.518158,A 160.773544,B 82.7231293,C -24.1120834,S 2,T 10,E1 0.0,E2 0.0,E3
0.0,E4 0.0,E5 0.0,E6 0.0}
DECL FDAT FP115={TOOL_NO 10,BASE_NO 14,IPO_FRAME #BASE,POINT2[] " ",TQ_STATE FALSE}
DECL LDAT LCPDAT114={VEL 2.00000,ACC 100.000,APO_DIST 100.000,APO_FAC 50.0000,AXIS_VEL 100.000,AXIS_ACC
100.000,ORI_TYP #JOINT,CIRC_TYP #BASE,JERK_FAC 50.0000,GEAR_JERK 50.0000,EXAX_IGN 0}
DECL E6POS XP116={X -907.514221,Y -357.045685,Z 462.108,A 160.773529,B 82.7231293,C -22.8284798,S 2,T 10,E1 0.0,E2 0.0,E3
0.0,E4 0.0,E5 0.0,E6 0.0}
DECL FDAT FP116={TOOL_NO 10,BASE_NO 14,IPO_FRAME #BASE,POINT2[] " ",TQ_STATE FALSE}

```

```

DECL LDAT LCPDAT115={VEL 2.00000,ACC 100.000,APO_DIST 100.000,APO_FAC 50.0000,AXIS_VEL 100.000,AXIS_ACC
100.000,ORI_TYP #JOINT,CIRC_TYP #BASE,JERK_FAC 50.0000,GEAR_JERK 50.0000,EXAX_IGN 0}
DECL E6POS XP117={X -904.913086,Y -363.414276,Z 463.417877,A 160.773514,B 82.7231216,C -21.3674736,S 2,T 10,E1 0.0,E2 0.0,E3
0.0,E4 0.0,E5 0.0,E6 0.0}
DECL FDAT FP117={TOOL_NO 10,BASE_NO 14,IPO_FRAME #BASE,POINT2[] " ",TQ_STATE FALSE}
DECL LDAT LCPDAT116={VEL 2.00000,ACC 100.000,APO_DIST 100.000,APO_FAC 50.0000,AXIS_VEL 100.000,AXIS_ACC
100.000,ORI_TYP #JOINT,CIRC_TYP #BASE,JERK_FAC 50.0000,GEAR_JERK 50.0000,EXAX_IGN 0}
DECL E6POS XP118={X -893.164795,Y -500.750305,Z 456.228058,A 160.683609,B 82.7551346,C -3.83837628,S 2,T 10,E1 0.0,E2 0.0,E3
0.0,E4 0.0,E5 0.0,E6 0.0}
DECL FDAT FP118={TOOL_NO 10,BASE_NO 14,IPO_FRAME #BASE,POINT2[] " ",TQ_STATE FALSE}
DECL LDAT LCPDAT117={VEL 2.00000,ACC 100.000,APO_DIST 100.000,APO_FAC 50.0000,AXIS_VEL 100.000,AXIS_ACC
100.000,ORI_TYP #JOINT,CIRC_TYP #BASE,JERK_FAC 50.0000,GEAR_JERK 50.0000,EXAX_IGN 0}
DECL E6POS XP119={X -901.113525,Y -370.166687,Z 462.675934,A 160.773499,B 82.7231,C -19.5958424,S 2,T 10,E1 0.0,E2 0.0,E3
0.0,E4 0.0,E5 0.0,E6 0.0}
DECL FDAT FP119={TOOL_NO 10,BASE_NO 14,IPO_FRAME #BASE,POINT2[] " ",TQ_STATE FALSE}
DECL LDAT LCPDAT118={VEL 2.00000,ACC 100.000,APO_DIST 100.000,APO_FAC 50.0000,AXIS_VEL 100.000,AXIS_ACC
100.000,ORI_TYP #JOINT,CIRC_TYP #BASE,JERK_FAC 50.0000,GEAR_JERK 50.0000,EXAX_IGN 0}
DECL E6POS XP120={X -894.760,Y -376.531403,Z 461.642365,A 160.773468,B 82.7230759,C -18.0520535,S 2,T 10,E1 0.0,E2 0.0,E3
0.0,E4 0.0,E5 0.0,E6 0.0}
DECL FDAT FP120={TOOL_NO 10,BASE_NO 14,IPO_FRAME #BASE,POINT2[] " ",TQ_STATE FALSE}
DECL LDAT LCPDAT119={VEL 2.00000,ACC 100.000,APO_DIST 100.000,APO_FAC 50.0000,AXIS_VEL 100.000,AXIS_ACC
100.000,ORI_TYP #JOINT,CIRC_TYP #BASE,JERK_FAC 50.0000,GEAR_JERK 50.0000,EXAX_IGN 0}
DECL E6POS XP121={X -887.266479,Y -387.750458,Z 460.265930,A 161.281876,B 82.4983,C -15.9268179,S 2,T 10,E1 0.0,E2 0.0,E3
0.0,E4 0.0,E5 0.0,E6 0.0}
DECL FDAT FP121={TOOL_NO 10,BASE_NO 14,IPO_FRAME #BASE,POINT2[] " ",TQ_STATE FALSE}
DECL LDAT LCPDAT120={VEL 2.00000,ACC 100.000,APO_DIST 100.000,APO_FAC 50.0000,AXIS_VEL 100.000,AXIS_ACC
100.000,ORI_TYP #JOINT,CIRC_TYP #BASE,JERK_FAC 50.0000,GEAR_JERK 50.0000,EXAX_IGN 0}
DECL E6POS XP122={X -876.822266,Y -402.730194,Z 458.329529,A 161.783051,B 82.2191,C -13.0101032,S 2,T 10,E1 0.0,E2 0.0,E3
0.0,E4 0.0,E5 0.0,E6 0.0}
DECL FDAT FP122={TOOL_NO 10,BASE_NO 14,IPO_FRAME #BASE,POINT2[] " ",TQ_STATE FALSE}
DECL LDAT LCPDAT121={VEL 2.00000,ACC 100.000,APO_DIST 100.000,APO_FAC 50.0000,AXIS_VEL 100.000,AXIS_ACC
100.000,ORI_TYP #JOINT,CIRC_TYP #BASE,JERK_FAC 50.0000,GEAR_JERK 50.0000,EXAX_IGN 0}
DECL E6POS XP123={X -865.900085,Y -434.253265,Z 455.550690,A 162.148514,B 81.9090729,C -8.93958759,S 2,T 10,E1 0.0,E2 0.0,E3
0.0,E4 0.0,E5 0.0,E6 0.0}
DECL FDAT FP123={TOOL_NO 10,BASE_NO 14,IPO_FRAME #BASE,POINT2[] " ",TQ_STATE FALSE}
DECL LDAT LCPDAT122={VEL 2.00000,ACC 100.000,APO_DIST 100.000,APO_FAC 50.0000,AXIS_VEL 100.000,AXIS_ACC
100.000,ORI_TYP #JOINT,CIRC_TYP #BASE,JERK_FAC 50.0000,GEAR_JERK 50.0000,EXAX_IGN 0}
DECL E6POS XP124={X -846.295959,Y -437.320831,Z 452.722534,A 162.723984,B 81.3396378,C -7.73239183,S 2,T 10,E1 0.0,E2 0.0,E3
0.0,E4 0.0,E5 0.0,E6 0.0}
DECL FDAT FP124={TOOL_NO 10,BASE_NO 14,IPO_FRAME #BASE,POINT2[] " ",TQ_STATE FALSE}
DECL LDAT LCPDAT123={VEL 2.00000,ACC 100.000,APO_DIST 100.000,APO_FAC 50.0000,AXIS_VEL 100.000,AXIS_ACC
100.000,ORI_TYP #JOINT,CIRC_TYP #BASE,JERK_FAC 50.0000,GEAR_JERK 50.0000,EXAX_IGN 0}
DECL E6POS XP125={X -846.296,Y -437.320801,Z 452.722595,A 162.723953,B 81.3396225,C -5.18779087,S 2,T 10,E1 0.0,E2 0.0,E3
0.0,E4 0.0,E5 0.0,E6 0.0}
DECL FDAT FP125={TOOL_NO 10,BASE_NO 14,IPO_FRAME #BASE,POINT2[] " ",TQ_STATE FALSE}
DECL LDAT LCPDAT124={VEL 2.00000,ACC 100.000,APO_DIST 100.000,APO_FAC 50.0000,AXIS_VEL 100.000,AXIS_ACC
100.000,ORI_TYP #JOINT,CIRC_TYP #BASE,JERK_FAC 50.0000,GEAR_JERK 50.0000,EXAX_IGN 0}
DECL E6POS XP126={X -865.658630,Y -651.212219,Z 449.249146,A 113.271797,B 81.2488937,C -25.6479130,S 2,T 10,E1 0.0,E2 0.0,E3
0.0,E4 0.0,E5 0.0,E6 0.0}
DECL FDAT FP126={TOOL_NO 10,BASE_NO 14,IPO_FRAME #BASE,POINT2[] " ",TQ_STATE FALSE}
DECL LDAT LCPDAT125={VEL 2.00000,ACC 100.000,APO_DIST 100.000,APO_FAC 50.0000,AXIS_VEL 100.000,AXIS_ACC
100.000,ORI_TYP #JOINT,CIRC_TYP #BASE,JERK_FAC 50.0000,GEAR_JERK 50.0000,EXAX_IGN 0}
DECL E6POS XP127={X -901.583801,Y -692.293274,Z 477.707916,A 88.4838181,B 85.0894241,C -50.2808914,S 2,T 10,E1 0.0,E2 0.0,E3
0.0,E4 0.0,E5 0.0,E6 0.0}
DECL FDAT FP127={TOOL_NO 10,BASE_NO 14,IPO_FRAME #BASE,POINT2[] " ",TQ_STATE FALSE}
DECL LDAT LCPDAT126={VEL 2.00000,ACC 100.000,APO_DIST 100.000,APO_FAC 50.0000,AXIS_VEL 100.000,AXIS_ACC
100.000,ORI_TYP #JOINT,CIRC_TYP #BASE,JERK_FAC 50.0000,GEAR_JERK 50.0000,EXAX_IGN 0}
DECL E6POS XP128={X -906.891235,Y -697.673401,Z 477.235962,A 90.9931412,B 84.8992691,C -47.7811279,S 2,T 10,E1 0.0,E2 0.0,E3
0.0,E4 0.0,E5 0.0,E6 0.0}
DECL FDAT FP128={TOOL_NO 10,BASE_NO 14,IPO_FRAME #BASE,POINT2[] " ",TQ_STATE FALSE}
DECL LDAT LCPDAT127={VEL 2.00000,ACC 100.000,APO_DIST 100.000,APO_FAC 50.0000,AXIS_VEL 100.000,AXIS_ACC
100.000,ORI_TYP #JOINT,CIRC_TYP #BASE,JERK_FAC 50.0000,GEAR_JERK 50.0000,EXAX_IGN 0}
DECL E6POS XP129={X -918.412170,Y -687.994324,Z 478.178528,A 92.8851624,B 84.7449875,C -46.9598656,S 2,T 10,E1 0.0,E2 0.0,E3
0.0,E4 0.0,E5 0.0,E6 0.0}
DECL FDAT FP129={TOOL_NO 10,BASE_NO 14,IPO_FRAME #BASE,POINT2[] " ",TQ_STATE FALSE}
DECL LDAT LCPDAT128={VEL 2.00000,ACC 100.000,APO_DIST 100.000,APO_FAC 50.0000,AXIS_VEL 100.000,AXIS_ACC
100.000,ORI_TYP #JOINT,CIRC_TYP #BASE,JERK_FAC 50.0000,GEAR_JERK 50.0000,EXAX_IGN 0}
DECL E6POS XP130={X -914.710876,Y -661.751221,Z 480.561,A 92.8813171,B 84.7451401,C -50.3895493,S 2,T 10,E1 0.0,E2 0.0,E3
0.0,E4 0.0,E5 0.0,E6 0.0}
DECL FDAT FP130={TOOL_NO 10,BASE_NO 14,IPO_FRAME #BASE,POINT2[] " ",TQ_STATE FALSE}
DECL LDAT LCPDAT129={VEL 2.00000,ACC 100.000,APO_DIST 100.000,APO_FAC 50.0000,AXIS_VEL 100.000,AXIS_ACC
100.000,ORI_TYP #JOINT,CIRC_TYP #BASE,JERK_FAC 50.0000,GEAR_JERK 50.0000,EXAX_IGN 0}
DECL E6POS XP131={X -910.204590,Y -630.995,Z 483.362762,A 92.8748169,B 84.7454071,C -54.6952324,S 2,T 10,E1 0.0,E2 0.0,E3
0.0,E4 0.0,E5 0.0,E6 0.0}
DECL FDAT FP131={TOOL_NO 10,BASE_NO 14,IPO_FRAME #BASE,POINT2[] " ",TQ_STATE FALSE}

```



```

DECL LDAT LCPDAT130={VEL 2.00000,ACC 100.000,APO_DIST 100.000,APO_FAC 50.0000,AXIS_VEL 100.000,AXIS_ACC
100.000,ORI_TYP #JOINT,CIRC_TYP #BASE,JERK_FAC 50.0000,GEAR_JERK 50.0000,EXAX_IGN 0}
DECL E6POS XP132={X -899.113220,Y -575.253,Z 488.386658,A 92.7502441,B 84.7506256,C -62.8942719,S 2,T 10,E1 0.0,E2 0.0,E3
0.0,E4 0.0,E5 0.0,E6 0.0}
DECL FDAT FP132={TOOL_NO 10,BASE_NO 14,IPO_FRAME #BASE,POINT2[] " ",TQ_STATE TRUE}
DECL LDAT LCPDAT131={VEL 2.00000,ACC 100.000,APO_DIST 100.000,APO_FAC 50.0000,AXIS_VEL 100.000,AXIS_ACC
100.000,ORI_TYP #JOINT,CIRC_TYP #BASE,JERK_FAC 50.0000,GEAR_JERK 50.0000,EXAX_IGN 0}
DECL TM_SUGG_T LAST_TQM={TM_ID[] "TM124"}
DECL TQM_TQDAT_T TM1={T11 200,T12 200,T13 200,T14 200,T15 200,T16 200,T21 1000,T22 1000,T23 1000,T24 1000,T25
1000,T26 1000,K1 280,K2 280,K3 280,K4 280,K5 280,K6 280,O1 20,O2 30,ID 1,OVM 0,TMF 1.00000}
DECL E6POS XP133={X -908.608887,Y -611.111572,Z 485.205139,A 93.1594543,B 84.7207794,C -57.8779297,S 2,T 10,E1 0.0,E2 0.0,E3
0.0,E4 0.0,E5 0.0,E6 0.0}
DECL FDAT FP133={TOOL_NO 10,BASE_NO 14,IPO_FRAME #BASE,POINT2[] " ",TQ_STATE TRUE}
DECL LDAT LCPDAT132={VEL 2.00000,ACC 100.000,APO_DIST 100.000,APO_FAC 50.0000,AXIS_VEL 100.000,AXIS_ACC
100.000,ORI_TYP #JOINT,CIRC_TYP #BASE,JERK_FAC 50.0000,GEAR_JERK 50.0000,EXAX_IGN 0}
DECL TQM_TQDAT_T TM2={T11 2,T12 2,T13 8,T14 6,T15 9,T16 1,T21 21058,T22 14690,T23 4676,T24 8752,T25 8006,T26 6174,K1
299,K2 301,K3 299,K4 309,K5 300,K6 301,O1 20,O2 30,ID 2,OVM 100,TMF 1.00000}
DECL E6POS XP134={X -903.084045,Y -593.733215,Z 486.766479,A 92.3742447,B 84.7606277,C -61.3843880,S 2,T 10,E1 0.0,E2 0.0,E3
0.0,E4 0.0,E5 0.0,E6 0.0}
DECL FDAT FP134={TOOL_NO 10,BASE_NO 14,IPO_FRAME #BASE,POINT2[] " ",TQ_STATE TRUE}
DECL LDAT LCPDAT133={VEL 2.00000,ACC 100.000,APO_DIST 100.000,APO_FAC 50.0000,AXIS_VEL 100.000,AXIS_ACC
100.000,ORI_TYP #JOINT,CIRC_TYP #BASE,JERK_FAC 50.0000,GEAR_JERK 50.0000,EXAX_IGN 0}
DECL TQM_TQDAT_T TM3={T11 1,T12 6,T13 8,T14 6,T15 9,T16 1,T21 14445,T22 20219,T23 4716,T24 6706,T25 4275,T26 5618,K1
299,K2 301,K3 299,K4 309,K5 300,K6 301,O1 20,O2 30,ID 3,OVM 100,TMF 1.00000}
DECL E6POS XP135={X -893.268921,Y -562.854675,Z 489.527588,A 94.4827881,B 84.6741180,C -64.4937592,S 2,T 10,E1 0.0,E2 0.0,E3
0.0,E4 0.0,E5 0.0,E6 0.0}
DECL FDAT FP135={TOOL_NO 10,BASE_NO 14,IPO_FRAME #BASE,POINT2[] " ",TQ_STATE TRUE}
DECL LDAT LCPDAT134={VEL 2.00000,ACC 100.000,APO_DIST 100.000,APO_FAC 50.0000,AXIS_VEL 100.000,AXIS_ACC
100.000,ORI_TYP #JOINT,CIRC_TYP #BASE,JERK_FAC 50.0000,GEAR_JERK 50.0000,EXAX_IGN 0}
DECL TQM_TQDAT_T TM4={T11 2,T12 1,T13 8,T14 8,T15 10,T16 0,T21 14053,T22 9881,T23 4335,T24 12336,T25 4441,T26 5083,K1
299,K2 301,K3 299,K4 309,K5 300,K6 301,O1 20,O2 30,ID 4,OVM 100,TMF 1.00000}
DECL E6POS XP136={X -887.092346,Y -533.366089,Z 492.199982,A 94.4402084,B 84.6765747,C -68.8730698,S 2,T 10,E1 0.0,E2 0.0,E3
0.0,E4 0.0,E5 0.0,E6 0.0}
DECL FDAT FP136={TOOL_NO 10,BASE_NO 14,IPO_FRAME #BASE,POINT2[] " ",TQ_STATE TRUE}
DECL LDAT LCPDAT135={VEL 2.00000,ACC 100.000,APO_DIST 100.000,APO_FAC 50.0000,AXIS_VEL 100.000,AXIS_ACC
100.000,ORI_TYP #JOINT,CIRC_TYP #BASE,JERK_FAC 50.0000,GEAR_JERK 50.0000,EXAX_IGN 0}
DECL TQM_TQDAT_T TM5={T11 1,T12 0,T13 8,T14 10,T15 9,T16 1,T21 22664,T22 11891,T23 5678,T24 18163,T25 5127,T26 4440,K1
299,K2 301,K3 299,K4 309,K5 300,K6 301,O1 20,O2 30,ID 5,OVM 100,TMF 1.00000}
DECL E6POS XP137={X -884.573547,Y -493.741608,Z 495.847473,A 95.7415695,B 84.6417694,C -72.8877716,S 2,T 10,E1 0.0,E2 0.0,E3
0.0,E4 0.0,E5 0.0,E6 0.0}
DECL FDAT FP137={TOOL_NO 10,BASE_NO 14,IPO_FRAME #BASE,POINT2[] " ",TQ_STATE TRUE}
DECL LDAT LCPDAT136={VEL 2.00000,ACC 100.000,APO_DIST 100.000,APO_FAC 50.0000,AXIS_VEL 100.000,AXIS_ACC
100.000,ORI_TYP #JOINT,CIRC_TYP #BASE,JERK_FAC 50.0000,GEAR_JERK 50.0000,EXAX_IGN 0}
DECL TQM_TQDAT_T TM6={T11 0,T12 0,T13 0,T14 0,T15 0,T16 0,T21 1383,T22 349,T23 102,T24 165,T25 472,T26 115,K1 299,K2
301,K3 299,K4 309,K5 300,K6 301,O1 20,O2 30,ID 6,OVM 100,TMF 1.00000}
DECL E6POS XP138={X -883.433044,Y -463.081238,Z 498.691437,A 95.7262726,B 84.6426926,C -77.3170776,S 2,T 10,E1 0.0,E2 0.0,E3
0.0,E4 0.0,E5 0.0,E6 0.0}
DECL FDAT FP138={TOOL_NO 10,BASE_NO 14,IPO_FRAME #BASE,POINT2[] " ",TQ_STATE TRUE}
DECL LDAT LCPDAT137={VEL 2.00000,ACC 100.000,APO_DIST 100.000,APO_FAC 50.0000,AXIS_VEL 100.000,AXIS_ACC
100.000,ORI_TYP #JOINT,CIRC_TYP #BASE,JERK_FAC 50.0000,GEAR_JERK 50.0000,EXAX_IGN 0}
DECL TQM_TQDAT_T TM7={T11 2,T12 1,T13 7,T14 11,T15 7,T16 1,T21 22261,T22 9624,T23 4758,T24 9371,T25 10175,T26 6996,K1
299,K2 301,K3 299,K4 309,K5 300,K6 301,O1 20,O2 30,ID 7,OVM 100,TMF 1.00000}
DECL E6POS XP139={X -886.571,Y -430.096436,Z 501.796173,A 95.7204132,B 84.6430359,C -81.6378937,S 2,T 10,E1 0.0,E2 0.0,E3
0.0,E4 0.0,E5 0.0,E6 0.0}
DECL FDAT FP139={TOOL_NO 10,BASE_NO 14,IPO_FRAME #BASE,POINT2[] " ",TQ_STATE TRUE}
DECL LDAT LCPDAT138={VEL 2.00000,ACC 100.000,APO_DIST 100.000,APO_FAC 50.0000,AXIS_VEL 100.000,AXIS_ACC
100.000,ORI_TYP #JOINT,CIRC_TYP #BASE,JERK_FAC 50.0000,GEAR_JERK 50.0000,EXAX_IGN 0}
DECL TQM_TQDAT_T TM8={T11 2,T12 2,T13 7,T14 11,T15 5,T16 2,T21 11096,T22 11821,T23 6878,T24 13328,T25 6924,T26 5234,K1
299,K2 301,K3 299,K4 309,K5 300,K6 301,O1 20,O2 30,ID 8,OVM 100,TMF 1.00000}
DECL E6POS XP140={X -890.635803,Y -402.239716,Z 504.488037,A 96.5923920,B 84.6357574,C -84.4785233,S 2,T 10,E1 0.0,E2 0.0,E3
0.0,E4 0.0,E5 0.0,E6 0.0}
DECL FDAT FP140={TOOL_NO 10,BASE_NO 14,IPO_FRAME #BASE,POINT2[] " ",TQ_STATE TRUE}
DECL LDAT LCPDAT139={VEL 2.00000,ACC 100.000,APO_DIST 100.000,APO_FAC 50.0000,AXIS_VEL 100.000,AXIS_ACC
100.000,ORI_TYP #JOINT,CIRC_TYP #BASE,JERK_FAC 50.0000,GEAR_JERK 50.0000,EXAX_IGN 0}
DECL TQM_TQDAT_T TM9={T11 1,T12 1,T13 7,T14 9,T15 5,T16 2,T21 5558,T22 6945,T23 7918,T24 5428,T25 9370,T26 2581,K1
299,K2 301,K3 299,K4 309,K5 300,K6 301,O1 20,O2 30,ID 9,OVM 100,TMF 1.00000}
DECL E6POS XP141={X -895.063171,Y -384.073639,Z 506.230804,A 97.4870682,B 84.6314,C -86.5767746,S 2,T 10,E1 0.0,E2 0.0,E3
0.0,E4 0.0,E5 0.0,E6 0.0}
DECL FDAT FP141={TOOL_NO 10,BASE_NO 14,IPO_FRAME #BASE,POINT2[] " ",TQ_STATE TRUE}
DECL LDAT LCPDAT140={VEL 2.00000,ACC 100.000,APO_DIST 100.000,APO_FAC 50.0000,AXIS_VEL 100.000,AXIS_ACC
100.000,ORI_TYP #JOINT,CIRC_TYP #BASE,JERK_FAC 50.0000,GEAR_JERK 50.0000,EXAX_IGN 0}
DECL TQM_TQDAT_T TM10={T11 1,T12 2,T13 7,T14 10,T15 5,T16 2,T21 9763,T22 9512,T23 7918,T24 12514,T25 9370,T26 5271,K1
299,K2 301,K3 299,K4 309,K5 300,K6 301,O1 20,O2 30,ID 10,OVM 100,TMF 1.00000}
DECL E6POS XP142={X -903.541687,Y -350.494812,Z 509.463318,A 97.4870605,B 84.6314,C -91.1103363,S 2,T 10,E1 0.0,E2 0.0,E3
0.0,E4 0.0,E5 0.0,E6 0.0}

```

```

DECL FDAT FP142={TOOL_NO 10,BASE_NO 14,IPO_FRAME #BASE,POINT2[] " ",TQ_STATE TRUE}
DECL LDAT LCPDAT141={VEL 2.00000,ACC 100.000,APO_DIST 100.000,APO_FAC 50.0000,AXIS_VEL 100.000,AXIS_ACC
100.000,ORI_TYP #JOINT,CIRC_TYP #BASE,JERK_FAC 50.0000,GEAR_JERK 50.0000,EXAX_IGN 0}
DECL TQM_TQDAT_T TM11={T11 1,T12 3,T13 7,T14 10,T15 3,T16 1,T21 11149,T22 14667,T23 6599,T24 13604,T25 10411,T26
4226,K1 299,K2 301,K3 299,K4 309,K5 300,K6 301,O1 20,O2 30,ID 11,OVM 100,TMF 1.00000}
DECL E6POS XP143={X -914.789063,Y -318.753296,Z 512.563049,A 99.4040222,B 84.6463165,C -93.8052902,S 2,T 10,E1 0.0,E2 0.0,E3
0.0,E4 0.0,E5 0.0,E6 0.0}
DECL FDAT FP143={TOOL_NO 10,BASE_NO 14,IPO_FRAME #BASE,POINT2[] " ",TQ_STATE TRUE}
DECL LDAT LCPDAT142={VEL 2.00000,ACC 100.000,APO_DIST 100.000,APO_FAC 50.0000,AXIS_VEL 100.000,AXIS_ACC
100.000,ORI_TYP #JOINT,CIRC_TYP #BASE,JERK_FAC 50.0000,GEAR_JERK 50.0000,EXAX_IGN 0}
DECL TQM_TQDAT_T TM12={T11 1,T12 3,T13 6,T14 9,T15 3,T16 0,T21 5964,T22 11894,T23 1474,T24 2355,T25 3089,T26 4223,K1
299,K2 301,K3 299,K4 309,K5 300,K6 301,O1 20,O2 30,ID 12,OVM 100,TMF 1.00000}
DECL E6POS XP144={X -923.528320,Y -297.077728,Z 514.707947,A 100.748756,B 84.6602478,C -95.8207397,S 2,T 10,E1 0.0,E2 0.0,E3
0.0,E4 0.0,E5 0.0,E6 0.0}
DECL FDAT FP144={TOOL_NO 10,BASE_NO 14,IPO_FRAME #BASE,POINT2[] " ",TQ_STATE TRUE}
DECL LDAT LCPDAT143={VEL 2.00000,ACC 100.000,APO_DIST 100.000,APO_FAC 50.0000,AXIS_VEL 100.000,AXIS_ACC
100.000,ORI_TYP #JOINT,CIRC_TYP #BASE,JERK_FAC 50.0000,GEAR_JERK 50.0000,EXAX_IGN 0}
DECL TQM_TQDAT_T TM13={T11 1,T12 4,T13 6,T14 9,T15 3,T16 2,T21 11234,T22 19073,T23 6973,T24 8330,T25 7168,T26 5325,K1
299,K2 301,K3 299,K4 309,K5 300,K6 301,O1 20,O2 30,ID 13,OVM 100,TMF 1.00000}
DECL E6POS XP145={X -934.187866,Y -274.651489,Z 516.971130,A 102.963005,B 84.6859360,C -97.0591,S 2,T 10,E1 0.0,E2 0.0,E3
0.0,E4 0.0,E5 0.0,E6 0.0}
DECL FDAT FP145={TOOL_NO 10,BASE_NO 14,IPO_FRAME #BASE,POINT2[] " ",TQ_STATE TRUE}
DECL LDAT LCPDAT144={VEL 2.00000,ACC 100.000,APO_DIST 100.000,APO_FAC 50.0000,AXIS_VEL 100.000,AXIS_ACC
100.000,ORI_TYP #JOINT,CIRC_TYP #BASE,JERK_FAC 50.0000,GEAR_JERK 50.0000,EXAX_IGN 0}
DECL TQM_TQDAT_T TM14={T11 0,T12 3,T13 5,T14 6,T15 1,T16 1,T21 5043,T22 13586,T23 6554,T24 1958,T25 1460,T26 4525,K1
299,K2 301,K3 299,K4 309,K5 300,K6 301,O1 20,O2 30,ID 14,OVM 100,TMF 1.00000}
DECL E6POS XP146={X -945.701416,Y -252.730103,Z 519.203857,A 104.116684,B 84.7046127,C -99.3548431,S 2,T 10,E1 0.0,E2 0.0,E3
0.0,E4 0.0,E5 0.0,E6 0.0}
DECL FDAT FP146={TOOL_NO 10,BASE_NO 14,IPO_FRAME #BASE,POINT2[] " ",TQ_STATE TRUE}
DECL LDAT LCPDAT145={VEL 2.00000,ACC 100.000,APO_DIST 100.000,APO_FAC 50.0000,AXIS_VEL 100.000,AXIS_ACC
100.000,ORI_TYP #JOINT,CIRC_TYP #BASE,JERK_FAC 50.0000,GEAR_JERK 50.0000,EXAX_IGN 0}
DECL TQM_TQDAT_T TM15={T11 1,T12 4,T13 5,T14 8,T15 2,T16 1,T21 7134,T22 17444,T23 6901,T24 6313,T25 8305,T26 7096,K1
299,K2 301,K3 299,K4 309,K5 300,K6 301,O1 20,O2 30,ID 15,OVM 100,TMF 1.00000}
DECL E6POS XP147={X -958.327332,Y -232.215561,Z 521.333252,A 104.757675,B 84.7175217,C -102.008560,S 2,T 10,E1 0.0,E2 0.0,E3
0.0,E4 0.0,E5 0.0,E6 0.0}
DECL FDAT FP147={TOOL_NO 10,BASE_NO 14,IPO_FRAME #BASE,POINT2[] " ",TQ_STATE TRUE}
DECL LDAT LCPDAT146={VEL 2.00000,ACC 100.000,APO_DIST 100.000,APO_FAC 50.0000,AXIS_VEL 100.000,AXIS_ACC
100.000,ORI_TYP #JOINT,CIRC_TYP #BASE,JERK_FAC 50.0000,GEAR_JERK 50.0000,EXAX_IGN 0}
DECL TQM_TQDAT_T TM16={T11 1,T12 5,T13 8,T14 6,T15 3,T16 3,T21 10258,T22 25787,T23 14127,T24 4938,T25 4686,T26 5820,K1
299,K2 301,K3 299,K4 309,K5 300,K6 301,O1 20,O2 30,ID 16,OVM 100,TMF 1.00000}
DECL E6POS XP148={X -958.327332,Y -232.215561,Z 521.333252,A 104.757675,B 84.7175217,C -102.008560,S 2,T 10,E1 0.0,E2 0.0,E3
0.0,E4 0.0,E5 0.0,E6 0.0}
DECL FDAT FP148={TOOL_NO 10,BASE_NO 14,IPO_FRAME #BASE,POINT2[] " ",TQ_STATE TRUE}
DECL LDAT LCPDAT147={VEL 2.00000,ACC 100.000,APO_DIST 100.000,APO_FAC 50.0000,AXIS_VEL 100.000,AXIS_ACC
100.000,ORI_TYP #JOINT,CIRC_TYP #BASE,JERK_FAC 50.0000,GEAR_JERK 50.0000,EXAX_IGN 0}
DECL TQM_TQDAT_T TM17={T11 1,T12 5,T13 8,T14 6,T15 3,T16 3,T21 10511,T22 25787,T23 14127,T24 4938,T25 4686,T26 5820,K1
299,K2 301,K3 299,K4 309,K5 300,K6 301,O1 20,O2 30,ID 17,OVM 100,TMF 1.00000}
DECL E6POS XP149={X -972.178467,Y -212.896301,Z 523.390320,A 105.458076,B 84.7347717,C -104.652069,S 2,T 10,E1 0.0,E2 0.0,E3
0.0,E4 0.0,E5 0.0,E6 0.0}
DECL FDAT FP149={TOOL_NO 10,BASE_NO 14,IPO_FRAME #BASE,POINT2[] " ",TQ_STATE TRUE}
DECL LDAT LCPDAT148={VEL 2.00000,ACC 100.000,APO_DIST 100.000,APO_FAC 50.0000,AXIS_VEL 100.000,AXIS_ACC
100.000,ORI_TYP #JOINT,CIRC_TYP #BASE,JERK_FAC 50.0000,GEAR_JERK 50.0000,EXAX_IGN 0}
DECL TQM_TQDAT_T TM18={T11 0,T12 5,T13 8,T14 8,T15 2,T16 1,T21 7383,T22 24905,T23 18187,T24 7031,T25 9021,T26 4979,K1
299,K2 301,K3 299,K4 309,K5 300,K6 301,O1 20,O2 30,ID 18,OVM 100,TMF 1.00000}
DECL E6POS XP150={X -987.884277,Y -192.324753,Z 525.605347,A 106.867859,B 84.7754898,C -107.034348,S 2,T 10,E1 0.0,E2 0.0,E3
0.0,E4 0.0,E5 0.0,E6 0.0}
DECL FDAT FP150={TOOL_NO 10,BASE_NO 14,IPO_FRAME #BASE,POINT2[] " ",TQ_STATE TRUE}
DECL LDAT LCPDAT149={VEL 2.00000,ACC 100.000,APO_DIST 100.000,APO_FAC 50.0000,AXIS_VEL 100.000,AXIS_ACC
100.000,ORI_TYP #JOINT,CIRC_TYP #BASE,JERK_FAC 50.0000,GEAR_JERK 50.0000,EXAX_IGN 0}
DECL TQM_TQDAT_T TM19={T11 0,T12 4,T13 4,T14 7,T15 3,T16 2,T21 6817,T22 16648,T23 3361,T24 4540,T25 11780,T26 4303,K1
299,K2 301,K3 299,K4 309,K5 300,K6 301,O1 20,O2 30,ID 19,OVM 100,TMF 1.00000}
DECL E6POS XP151={X -994.265625,Y -182.852753,Z 526.603088,A 106.867813,B 84.7754898,C -109.266396,S 2,T 10,E1 0.0,E2 0.0,E3
0.0,E4 0.0,E5 0.0,E6 0.0}
DECL FDAT FP151={TOOL_NO 10,BASE_NO 14,IPO_FRAME #BASE,POINT2[] " ",TQ_STATE TRUE}
DECL LDAT LCPDAT150={VEL 2.00000,ACC 100.000,APO_DIST 100.000,APO_FAC 50.0000,AXIS_VEL 100.000,AXIS_ACC
100.000,ORI_TYP #JOINT,CIRC_TYP #BASE,JERK_FAC 50.0000,GEAR_JERK 50.0000,EXAX_IGN 0}
DECL TQM_TQDAT_T TM20={T11 1,T12 5,T13 5,T14 7,T15 4,T16 3,T21 9923,T22 16821,T23 5594,T24 4540,T25 12799,T26 4388,K1
299,K2 301,K3 299,K4 309,K5 300,K6 301,O1 20,O2 30,ID 20,OVM 100,TMF 1.00000}
DECL E6POS XP152={X -989.133362,Y -177.767349,Z 515.049744,A 106.812904,B 84.7748413,C -123.454391,S 2,T 10,E1 0.0,E2 0.0,E3
0.0,E4 0.0,E5 0.0,E6 0.0}
DECL FDAT FP152={TOOL_NO 10,BASE_NO 14,IPO_FRAME #BASE,POINT2[] " ",TQ_STATE TRUE}
DECL LDAT LCPDAT151={VEL 2.00000,ACC 100.000,APO_DIST 100.000,APO_FAC 50.0000,AXIS_VEL 100.000,AXIS_ACC
100.000,ORI_TYP #JOINT,CIRC_TYP #BASE,JERK_FAC 50.0000,GEAR_JERK 50.0000,EXAX_IGN 0}
DECL TQM_TQDAT_T TM21={T11 3,T12 9,T13 4,T14 11,T15 15,T16 4,T21 16272,T22 36817,T23 8722,T24 11182,T25 17115,T26
9043,K1 299,K2 301,K3 299,K4 309,K5 300,K6 301,O1 20,O2 30,ID 21,OVM 100,TMF 1.00000}

```

```

DECL E6POS XP153={X -1017.22577,Y -163.439789,Z 517.069092,A 106.867653,B 84.7754822,C -112.111275,S 2,T 10,E1 0.0,E2 0.0,E3
0.0,E4 0.0,E5 0.0,E6 0.0}
DECL FDAT FP153={TOOL_NO 10,BASE_NO 14,IPO_FRAME #BASE,POINT2[] " ",TQ_STATE TRUE}
DECL LDAT LCPDAT152={VEL 2.00000,ACC 100.000,APO_DIST 100.000,APO_FAC 50.0000,AXIS_VEL 100.000,AXIS_ACC
100.000,ORI_TYP #JOINT,CIRC_TYP #BASE,JERK_FAC 50.0000,GEAR_JERK 50.0000,EXAX_IGN 0}
DECL TQM_TQDAT_T TM22={T11 0,T12 0,T13 0,T14 0,T15 0,T16 0,T21 0,T22 0,T23 0,T24 0,T25 0,T26 0,K1 299,K2 301,K3 299,K4
309,K5 300,K6 301,O1 20,O2 30,ID 22,OVM 100,TMF 1.00000}
DECL E6POS XP154={X -1019.77258,Y -165.386978,Z 516.945190,A 103.118408,B 84.6309891,C -114.375580,S 2,T 10,E1 0.0,E2 0.0,E3
0.0,E4 0.0,E5 0.0,E6 0.0}
DECL FDAT FP154={TOOL_NO 10,BASE_NO 14,IPO_FRAME #BASE,POINT2[] " ",TQ_STATE TRUE}
DECL LDAT LCPDAT153={VEL 2.00000,ACC 100.000,APO_DIST 100.000,APO_FAC 50.0000,AXIS_VEL 100.000,AXIS_ACC
100.000,ORI_TYP #JOINT,CIRC_TYP #BASE,JERK_FAC 50.0000,GEAR_JERK 50.0000,EXAX_IGN 0}
DECL TQM_TQDAT_T TM23={T11 0,T12 12,T13 4,T14 11,T15 5,T16 3,T21 14319,T22 31049,T23 5353,T24 4637,T25 8107,T26
2120,K1 299,K2 301,K3 299,K4 309,K5 300,K6 301,O1 20,O2 30,ID 23,OVM 100,TMF 1.00000}
DECL E6POS XP155={X -1020.90222,Y -166.211639,Z 516.890564,A 101.834541,B 84.5776062,C -114.392464,S 2,T 10,E1 0.0,E2 0.0,E3
0.0,E4 0.0,E5 0.0,E6 0.0}
DECL FDAT FP155={TOOL_NO 10,BASE_NO 14,IPO_FRAME #BASE,POINT2[] " ",TQ_STATE TRUE}
DECL LDAT LCPDAT154={VEL 2.00000,ACC 100.000,APO_DIST 100.000,APO_FAC 50.0000,AXIS_VEL 100.000,AXIS_ACC
100.000,ORI_TYP #JOINT,CIRC_TYP #BASE,JERK_FAC 50.0000,GEAR_JERK 50.0000,EXAX_IGN 0}
DECL TQM_TQDAT_T TM24={T11 2,T12 14,T13 6,T14 11,T15 5,T16 4,T21 21755,T22 31049,T23 10558,T24 4637,T25 8107,T26
2936,K1 299,K2 301,K3 299,K4 309,K5 300,K6 301,O1 20,O2 30,ID 24,OVM 100,TMF 1.00000}
DECL E6POS XP156={X -1010.17694,Y -174.561279,Z 515.906,A 101.834534,B 84.5776062,C -112.460419,S 2,T 10,E1 0.0,E2 0.0,E3
0.0,E4 0.0,E5 0.0,E6 0.0}
DECL FDAT FP156={TOOL_NO 10,BASE_NO 14,IPO_FRAME #BASE,POINT2[] " ",TQ_STATE TRUE}
DECL LDAT LCPDAT155={VEL 2.00000,ACC 100.000,APO_DIST 100.000,APO_FAC 50.0000,AXIS_VEL 100.000,AXIS_ACC
100.000,ORI_TYP #JOINT,CIRC_TYP #BASE,JERK_FAC 50.0000,GEAR_JERK 50.0000,EXAX_IGN 0}
DECL TQM_TQDAT_T TM25={T11 2,T12 15,T13 7,T14 11,T15 4,T16 5,T21 12213,T22 31632,T23 8915,T24 4002,T25 8067,T26
5796,K1 299,K2 301,K3 299,K4 309,K5 300,K6 301,O1 20,O2 30,ID 25,OVM 100,TMF 1.00000}
DECL E6POS XP157={X -997.436,Y -189.373047,Z 514.276306,A 101.053696,B 84.5505905,C -110.451347,S 2,T 10,E1 0.0,E2 0.0,E3
0.0,E4 0.0,E5 0.0,E6 0.0}
DECL FDAT FP157={TOOL_NO 10,BASE_NO 14,IPO_FRAME #BASE,POINT2[] " ",TQ_STATE TRUE}
DECL LDAT LCPDAT156={VEL 2.00000,ACC 100.000,APO_DIST 100.000,APO_FAC 50.0000,AXIS_VEL 100.000,AXIS_ACC
100.000,ORI_TYP #JOINT,CIRC_TYP #BASE,JERK_FAC 50.0000,GEAR_JERK 50.0000,EXAX_IGN 0}
DECL TQM_TQDAT_T TM26={T11 1,T12 12,T13 8,T14 11,T15 3,T16 6,T21 14047,T22 18688,T23 5114,T24 6277,T25 9980,T26
6193,K1 299,K2 301,K3 299,K4 309,K5 300,K6 301,O1 20,O2 30,ID 26,OVM 100,TMF 1.00000}
DECL E6POS XP158={X -984.281067,Y -205.123184,Z 512.557129,A 99.7797623,B 84.5108948,C -108.549751,S 2,T 10,E1 0.0,E2 0.0,E3
0.0,E4 0.0,E5 0.0,E6 0.0}
DECL FDAT FP158={TOOL_NO 10,BASE_NO 14,IPO_FRAME #BASE,POINT2[] " ",TQ_STATE TRUE}
DECL LDAT LCPDAT157={VEL 2.00000,ACC 100.000,APO_DIST 100.000,APO_FAC 50.0000,AXIS_VEL 100.000,AXIS_ACC
100.000,ORI_TYP #JOINT,CIRC_TYP #BASE,JERK_FAC 50.0000,GEAR_JERK 50.0000,EXAX_IGN 0}
DECL TQM_TQDAT_T TM27={T11 1,T12 10,T13 7,T14 9,T15 3,T16 6,T21 3935,T22 13261,T23 6446,T24 3161,T25 8144,T26 3278,K1
299,K2 301,K3 299,K4 309,K5 300,K6 301,O1 20,O2 30,ID 27,OVM 100,TMF 1.00000}
DECL E6POS XP159={X -975.996887,Y -213.567184,Z 511.619324,A 98.4209824,B 84.4702,C -108.001450,S 2,T 10,E1 0.0,E2 0.0,E3
0.0,E4 0.0,E5 0.0,E6 0.0}
DECL FDAT FP159={TOOL_NO 10,BASE_NO 14,IPO_FRAME #BASE,POINT2[] " ",TQ_STATE TRUE}
DECL LDAT LCPDAT158={VEL 2.00000,ACC 100.000,APO_DIST 100.000,APO_FAC 50.0000,AXIS_VEL 100.000,AXIS_ACC
100.000,ORI_TYP #JOINT,CIRC_TYP #BASE,JERK_FAC 50.0000,GEAR_JERK 50.0000,EXAX_IGN 0}
DECL TQM_TQDAT_T TM28={T11 2,T12 13,T13 8,T14 11,T15 4,T16 6,T21 16113,T22 24739,T23 8389,T24 5517,T25 8144,T26
4409,K1 299,K2 301,K3 299,K4 309,K5 300,K6 301,O1 20,O2 30,ID 28,OVM 100,TMF 1.00000}
DECL E6POS XP160={X -955.086731,Y -240.435074,Z 508.748535,A 98.4207306,B 84.4701920,C -103.425224,S 2,T 10,E1 0.0,E2 0.0,E3
0.0,E4 0.0,E5 0.0,E6 0.0}
DECL FDAT FP160={TOOL_NO 10,BASE_NO 14,IPO_FRAME #BASE,POINT2[] " ",TQ_STATE TRUE}
DECL LDAT LCPDAT159={VEL 2.00000,ACC 100.000,APO_DIST 100.000,APO_FAC 50.0000,AXIS_VEL 100.000,AXIS_ACC
100.000,ORI_TYP #JOINT,CIRC_TYP #BASE,JERK_FAC 50.0000,GEAR_JERK 50.0000,EXAX_IGN 0}
DECL TQM_TQDAT_T TM29={T11 0,T12 10,T13 8,T14 8,T15 2,T16 5,T21 2085,T22 27213,T23 2309,T24 929,T25 1538,T26 2434,K1
299,K2 301,K3 299,K4 309,K5 300,K6 301,O1 20,O2 30,ID 29,OVM 100,TMF 1.00000}
DECL E6POS XP161={X -940.461853,Y -266.326569,Z 506.056458,A 97.6759567,B 84.4580,C -99.9981537,S 2,T 10,E1 0.0,E2 0.0,E3
0.0,E4 0.0,E5 0.0,E6 0.0}
DECL FDAT FP161={TOOL_NO 10,BASE_NO 14,IPO_FRAME #BASE,POINT2[] " ",TQ_STATE TRUE}
DECL LDAT LCPDAT160={VEL 2.00000,ACC 100.000,APO_DIST 100.000,APO_FAC 50.0000,AXIS_VEL 100.000,AXIS_ACC
100.000,ORI_TYP #JOINT,CIRC_TYP #BASE,JERK_FAC 50.0000,GEAR_JERK 50.0000,EXAX_IGN 0}
DECL TQM_TQDAT_T TM30={T11 1,T12 12,T13 9,T14 10,T15 5,T16 6,T21 12137,T22 28712,T23 7679,T24 5686,T25 7638,T26
6176,K1 299,K2 301,K3 299,K4 309,K5 300,K6 301,O1 20,O2 30,ID 30,OVM 100,TMF 1.00000}
DECL E6POS XP162={X -925.854675,Y -292.521484,Z 503.347565,A 97.6757126,B 84.4580,C -95.9655228,S 2,T 10,E1 0.0,E2 0.0,E3
0.0,E4 0.0,E5 0.0,E6 0.0}
DECL FDAT FP162={TOOL_NO 10,BASE_NO 14,IPO_FRAME #BASE,POINT2[] " ",TQ_STATE TRUE}
DECL LDAT LCPDAT161={VEL 2.00000,ACC 100.000,APO_DIST 100.000,APO_FAC 50.0000,AXIS_VEL 100.000,AXIS_ACC
100.000,ORI_TYP #JOINT,CIRC_TYP #BASE,JERK_FAC 50.0000,GEAR_JERK 50.0000,EXAX_IGN 0}
DECL TQM_TQDAT_T TM31={T11 0,T12 10,T13 8,T14 7,T15 4,T16 6,T21 3168,T22 12477,T23 2832,T24 5457,T25 964,T26 4753,K1
299,K2 301,K3 299,K4 309,K5 300,K6 301,O1 20,O2 30,ID 31,OVM 100,TMF 1.00000}
DECL E6POS XP163={X -913.848572,Y -316.313416,Z 500.902954,A 96.2442932,B 84.4509506,C -93.6285324,S 2,T 10,E1 0.0,E2 0.0,E3
0.0,E4 0.0,E5 0.0,E6 0.0}
DECL FDAT FP163={TOOL_NO 10,BASE_NO 14,IPO_FRAME #BASE,POINT2[] " ",TQ_STATE TRUE}
DECL LDAT LCPDAT162={VEL 2.00000,ACC 100.000,APO_DIST 100.000,APO_FAC 50.0000,AXIS_VEL 100.000,AXIS_ACC
100.000,ORI_TYP #JOINT,CIRC_TYP #BASE,JERK_FAC 50.0000,GEAR_JERK 50.0000,EXAX_IGN 0}

```

```

DECL TQM_TQDAT_T TM32={T11 1,T12 11,T13 8,T14 9,T15 6,T16 6,T21 11472,T22 17344,T23 4352,T24 8419,T25 7796,T26 4753,K1
299,K2 301,K3 299,K4 309,K5 300,K6 301,O1 20,O2 30,ID 32,OVM 100,TMF 1.00000}
DECL E6POS XP164={X -899.913452,Y -355.589569,Z 496.961,A 97.8895187,B 84.4433212,C -86.4353638,S 2,T 10,E1 0.0,E2 0.0,E3
0.0,E4 0.0,E5 0.0,E6 0.0}
DECL FDAT FP164={TOOL_NO 10,BASE_NO 14,IPO_FRAME #BASE,POINT2[] " ",TQ_STATE TRUE}
DECL LDAT LCPDAT163={VEL 2.00000,ACC 100.000,APO_DIST 100.000,APO_FAC 50.0000,AXIS_VEL 100.000,AXIS_ACC
100.000,ORI_TYP #JOINT,CIRC_TYP #BASE,JERK_FAC 50.0000,GEAR_JERK 50.0000,EXAX_IGN 0}
DECL TQM_TQDAT_T TM33={T11 1,T12 10,T13 9,T14 7,T15 6,T16 6,T21 10284,T22 22706,T23 6824,T24 13200,T25 8093,T26
4310,K1 299,K2 301,K3 299,K4 309,K5 300,K6 301,O1 20,O2 30,ID 33,OVM 100,TMF 1.00000}
DECL E6POS XP165={X -892.206177,Y -388.634094,Z 493.669464,A 97.2231827,B 84.4522934,C -82.4590454,S 2,T 10,E1 0.0,E2 0.0,E3
0.0,E4 0.0,E5 0.0,E6 0.0}
DECL FDAT FP165={TOOL_NO 10,BASE_NO 14,IPO_FRAME #BASE,POINT2[] " ",TQ_STATE TRUE}
DECL LDAT LCPDAT164={VEL 2.00000,ACC 100.000,APO_DIST 100.000,APO_FAC 50.0000,AXIS_VEL 100.000,AXIS_ACC
100.000,ORI_TYP #JOINT,CIRC_TYP #BASE,JERK_FAC 50.0000,GEAR_JERK 50.0000,EXAX_IGN 0}
DECL TQM_TQDAT_T TM34={T11 1,T12 10,T13 8,T14 6,T15 7,T16 6,T21 10603,T22 18625,T23 4555,T24 12669,T25 7011,T26
3443,K1 299,K2 301,K3 299,K4 309,K5 300,K6 301,O1 20,O2 30,ID 34,OVM 100,TMF 1.00000}
DECL E6POS XP166={X -885.938,Y -426.733795,Z 489.915619,A 96.8851471,B 84.4600906,C -77.5201721,S 2,T 10,E1 0.0,E2 0.0,E3
0.0,E4 0.0,E5 0.0,E6 0.0}
DECL FDAT FP166={TOOL_NO 10,BASE_NO 14,IPO_FRAME #BASE,POINT2[] " ",TQ_STATE TRUE}
DECL LDAT LCPDAT165={VEL 2.00000,ACC 100.000,APO_DIST 100.000,APO_FAC 50.0000,AXIS_VEL 100.000,AXIS_ACC
100.000,ORI_TYP #JOINT,CIRC_TYP #BASE,JERK_FAC 50.0000,GEAR_JERK 50.0000,EXAX_IGN 0}
DECL TQM_TQDAT_T TM35={T11 1,T12 10,T13 9,T14 3,T15 8,T16 5,T21 13489,T22 14782,T23 7749,T24 10748,T25 6974,T26
5671,K1 299,K2 301,K3 299,K4 309,K5 300,K6 301,O1 20,O2 30,ID 35,OVM 100,TMF 1.00000}
DECL E6POS XP167={X -882.162964,Y -466.913940,Z 485.990601,A 96.8587494,B 84.4619141,C -72.1973953,S 2,T 10,E1 0.0,E2 0.0,E3
0.0,E4 0.0,E5 0.0,E6 0.0}
DECL FDAT FP167={TOOL_NO 10,BASE_NO 14,IPO_FRAME #BASE,POINT2[] " ",TQ_STATE TRUE}
DECL LDAT LCPDAT166={VEL 2.00000,ACC 100.000,APO_DIST 100.000,APO_FAC 50.0000,AXIS_VEL 100.000,AXIS_ACC
100.000,ORI_TYP #JOINT,CIRC_TYP #BASE,JERK_FAC 50.0000,GEAR_JERK 50.0000,EXAX_IGN 0}
DECL TQM_TQDAT_T TM36={T11 2,T12 9,T13 9,T14 3,T15 9,T16 5,T21 24284,T22 13943,T23 6304,T24 17790,T25 7803,T26 3873,K1
299,K2 301,K3 299,K4 309,K5 300,K6 301,O1 20,O2 30,ID 36,OVM 100,TMF 1.00000}
DECL E6POS XP168={X -886.569641,Y -528.767578,Z 480.044525,A 96.7595673,B 84.4688950,C -64.5135345,S 2,T 10,E1 0.0,E2 0.0,E3
0.0,E4 0.0,E5 0.0,E6 0.0}
DECL FDAT FP168={TOOL_NO 10,BASE_NO 14,IPO_FRAME #BASE,POINT2[] " ",TQ_STATE TRUE}
DECL LDAT LCPDAT167={VEL 2.00000,ACC 100.000,APO_DIST 100.000,APO_FAC 50.0000,AXIS_VEL 100.000,AXIS_ACC
100.000,ORI_TYP #JOINT,CIRC_TYP #BASE,JERK_FAC 50.0000,GEAR_JERK 50.0000,EXAX_IGN 0}
DECL TQM_TQDAT_T TM37={T11 200,T12 200,T13 200,T14 200,T15 200,T16 200,T21 1000,T22 1000,T23 1000,T24 1000,T25
1000,T26 1000,K1 304,K2 307,K3 302,K4 302,K5 302,K6 304,O1 20,O2 30,ID 37,OVM 0,TMF 1.00000}
DECL E6POS XP169={X -882.970825,Y -511.742249,Z 481.654541,A 95.4928284,B 84.5190659,C -67.6184769,S 2,T 10,E1 0.0,E2 0.0,E3
0.0,E4 0.0,E5 0.0,E6 0.0}
DECL FDAT FP169={TOOL_NO 10,BASE_NO 14,IPO_FRAME #BASE,POINT2[] " ",TQ_STATE TRUE}
DECL LDAT LCPDAT168={VEL 2.00000,ACC 100.000,APO_DIST 100.000,APO_FAC 50.0000,AXIS_VEL 100.000,AXIS_ACC
100.000,ORI_TYP #JOINT,CIRC_TYP #BASE,JERK_FAC 50.0000,GEAR_JERK 50.0000,EXAX_IGN 0}
DECL TQM_TQDAT_T TM38={T11 2,T12 9,T13 8,T14 5,T15 9,T16 5,T21 21298,T22 13315,T23 5143,T24 15111,T25 8162,T26 4249,K1
299,K2 301,K3 299,K4 309,K5 300,K6 301,O1 20,O2 30,ID 38,OVM 100,TMF 1.00000}
DECL E6POS XP170={X -880.964,Y -538.829773,Z 479.047394,A 96.3624954,B 84.4775772,C -62.9689484,S 2,T 10,E1 0.0,E2 0.0,E3
0.0,E4 0.0,E5 0.0,E6 0.0}
DECL FDAT FP170={TOOL_NO 10,BASE_NO 14,IPO_FRAME #BASE,POINT2[] " ",TQ_STATE TRUE}
DECL LDAT LCPDAT169={VEL 2.00000,ACC 100.000,APO_DIST 100.000,APO_FAC 50.0000,AXIS_VEL 100.000,AXIS_ACC
100.000,ORI_TYP #JOINT,CIRC_TYP #BASE,JERK_FAC 50.0000,GEAR_JERK 50.0000,EXAX_IGN 0}
DECL TQM_TQDAT_T TM39={T11 2,T12 9,T13 8,T14 6,T15 9,T16 5,T21 19994,T22 6933,T23 5578,T24 12621,T25 6430,T26 6366,K1
299,K2 301,K3 299,K4 309,K5 300,K6 301,O1 20,O2 30,ID 39,OVM 100,TMF 1.00000}
DECL E6POS XP171={X -878.082825,Y -572.356323,Z 475.772919,A 96.3162,B 84.4805679,C -58.4815331,S 2,T 10,E1 0.0,E2 0.0,E3
0.0,E4 0.0,E5 0.0,E6 0.0}
DECL FDAT FP171={TOOL_NO 10,BASE_NO 14,IPO_FRAME #BASE,POINT2[] " ",TQ_STATE TRUE}
DECL LDAT LCPDAT170={VEL 2.00000,ACC 100.000,APO_DIST 100.000,APO_FAC 50.0000,AXIS_VEL 100.000,AXIS_ACC
100.000,ORI_TYP #JOINT,CIRC_TYP #BASE,JERK_FAC 50.0000,GEAR_JERK 50.0000,EXAX_IGN 0}
DECL TQM_TQDAT_T TM40={T11 2,T12 9,T13 8,T14 8,T15 9,T16 4,T21 21397,T22 11368,T23 3987,T24 16813,T25 6383,T26 5541,K1
299,K2 301,K3 299,K4 309,K5 300,K6 301,O1 20,O2 30,ID 40,OVM 100,TMF 1.00000}
DECL E6POS XP172={X -877.897156,Y -618.430908,Z 471.297241,A 96.6310806,B 84.4556427,C -52.5925407,S 2,T 10,E1 0.0,E2 0.0,E3
0.0,E4 0.0,E5 0.0,E6 0.0}
DECL FDAT FP172={TOOL_NO 10,BASE_NO 14,IPO_FRAME #BASE,POINT2[] " ",TQ_STATE TRUE}
DECL LDAT LCPDAT171={VEL 2.00000,ACC 100.000,APO_DIST 100.000,APO_FAC 50.0000,AXIS_VEL 100.000,AXIS_ACC
100.000,ORI_TYP #JOINT,CIRC_TYP #BASE,JERK_FAC 50.0000,GEAR_JERK 50.0000,EXAX_IGN 0}
DECL TQM_TQDAT_T TM41={T11 2,T12 9,T13 8,T14 9,T15 11,T16 4,T21 18877,T22 8202,T23 3682,T24 15842,T25 7362,T26 5479,K1
299,K2 301,K3 299,K4 309,K5 300,K6 301,O1 20,O2 30,ID 41,OVM 100,TMF 1.00000}
DECL E6POS XP173={X -883.790039,Y -660.476318,Z 467.270386,A 96.5233841,B 84.4611435,C -47.1738472,S 2,T 10,E1 0.0,E2 0.0,E3
0.0,E4 0.0,E5 0.0,E6 0.0}
DECL FDAT FP173={TOOL_NO 10,BASE_NO 14,IPO_FRAME #BASE,POINT2[] " ",TQ_STATE TRUE}
DECL LDAT LCPDAT172={VEL 2.00000,ACC 100.000,APO_DIST 100.000,APO_FAC 50.0000,AXIS_VEL 100.000,AXIS_ACC
100.000,ORI_TYP #JOINT,CIRC_TYP #BASE,JERK_FAC 50.0000,GEAR_JERK 50.0000,EXAX_IGN 0}
DECL TQM_TQDAT_T TM42={T11 3,T12 9,T13 10,T14 9,T15 11,T16 6,T21 15825,T22 45737,T23 12607,T24 10648,T25 6701,T26
5668,K1 299,K2 301,K3 299,K4 309,K5 300,K6 301,O1 20,O2 30,ID 42,OVM 100,TMF 1.00000}
DECL E6POS XP174={X -883.767883,Y -660.482849,Z 467.250183,A 96.4691,B 84.4640198,C -40.9509125,S 2,T 10,E1 0.0,E2 0.0,E3
0.0,E4 0.0,E5 0.0,E6 0.0}
DECL FDAT FP174={TOOL_NO 10,BASE_NO 14,IPO_FRAME #BASE,POINT2[] " ",TQ_STATE TRUE}

```

```

DECL LDAT LCPDAT173={VEL 2.00000,ACC 100.000,APO_DIST 100.000,APO_FAC 50.0000,AXIS_VEL 100.000,AXIS_ACC
100.000,ORI_TYP #JOINT,CIRC_TYP #BASE,JERK_FAC 50.0000,GEAR_JERK 50.0000,EXAX_IGN 0}
DECL TQM_TQDAT_T TM43={T11 2,T12 1,T13 9,T14 10,T15 10,T16 5,T21 29025,T22 18457,T23 5861,T24 7978,T25 14283,T26
7463,K1 299,K2 301,K3 299,K4 309,K5 300,K6 301,O1 20,O2 30,ID 43,OVM 100,TMF 1.00000}
DECL E6POS XP175={X -939.490173,Y -772.737732,Z 537.783813,A -25.7074,B 82.2193146,C -144.978897,S 2,T 10,E1 0.0,E2 0.0,E3
0.0,E4 0.0,E5 0.0,E6 0.0}
DECL FDAT FP175={TOOL_NO 10,BASE_NO 14,IPO_FRAME #BASE,POINT2[] " ",TQ_STATE TRUE}
DECL LDAT LCPDAT174={VEL 2.00000,ACC 100.000,APO_DIST 100.000,APO_FAC 50.0000,AXIS_VEL 100.000,AXIS_ACC
100.000,ORI_TYP #JOINT,CIRC_TYP #BASE,JERK_FAC 50.0000,GEAR_JERK 50.0000,EXAX_IGN 0}
DECL TQM_TQDAT_T TM44={T11 4,T12 10,T13 8,T14 18,T15 9,T16 3,T21 25071,T22 105066,T23 20727,T24 13859,T25 27666,T26
9659,K1 299,K2 301,K3 299,K4 309,K5 300,K6 301,O1 20,O2 30,ID 44,OVM 100,TMF 1.00000}
DECL E6POS XP176={X -947.418152,Y -763.196350,Z 536.260864,A -27.1570148,B 82.3085098,C -157.234695,S 2,T 10,E1 0.0,E2
0.0,E3 0.0,E4 0.0,E5 0.0,E6 0.0}
DECL FDAT FP176={TOOL_NO 10,BASE_NO 14,IPO_FRAME #BASE,POINT2[] " ",TQ_STATE TRUE}
DECL LDAT LCPDAT175={VEL 2.00000,ACC 100.000,APO_DIST 100.000,APO_FAC 50.0000,AXIS_VEL 100.000,AXIS_ACC
100.000,ORI_TYP #JOINT,CIRC_TYP #BASE,JERK_FAC 50.0000,GEAR_JERK 50.0000,EXAX_IGN 0}
DECL TQM_TQDAT_T TM45={T11 1,T12 10,T13 7,T14 8,T15 10,T16 1,T21 24161,T22 44946,T23 8962,T24 9290,T25 7486,T26
4269,K1 299,K2 301,K3 299,K4 309,K5 300,K6 300,O1 20,O2 30,ID 45,OVM 100,TMF 1.00000}
DECL E6POS XP177={X -948.879089,Y -761.476318,Z 535.979309,A -28.4633217,B 82.5709534,C -159.028351,S 2,T 10,E1 0.0,E2
0.0,E3 0.0,E4 0.0,E5 0.0,E6 0.0}
DECL FDAT FP177={TOOL_NO 10,BASE_NO 14,IPO_FRAME #BASE,POINT2[] " ",TQ_STATE TRUE}
DECL LDAT LCPDAT176={VEL 2.00000,ACC 100.000,APO_DIST 100.000,APO_FAC 50.0000,AXIS_VEL 100.000,AXIS_ACC
100.000,ORI_TYP #JOINT,CIRC_TYP #BASE,JERK_FAC 50.0000,GEAR_JERK 50.0000,EXAX_IGN 0}
DECL TQM_TQDAT_T TM46={T11 1,T12 11,T13 7,T14 9,T15 10,T16 1,T21 24161,T22 44946,T23 8962,T24 9290,T25 9442,T26
4269,K1 299,K2 301,K3 299,K4 309,K5 300,K6 300,O1 20,O2 30,ID 46,OVM 100,TMF 1.00000}
DECL E6POS XP178={X -938.644104,Y -735.582520,Z 535.543579,A -28.4633312,B 82.5709610,C -162.801437,S 2,T 10,E1 0.0,E2
0.0,E3 0.0,E4 0.0,E5 0.0,E6 0.0}
DECL FDAT FP178={TOOL_NO 10,BASE_NO 14,IPO_FRAME #BASE,POINT2[] " ",TQ_STATE TRUE}
DECL LDAT LCPDAT177={VEL 2.00000,ACC 100.000,APO_DIST 100.000,APO_FAC 50.0000,AXIS_VEL 100.000,AXIS_ACC
100.000,ORI_TYP #JOINT,CIRC_TYP #BASE,JERK_FAC 50.0000,GEAR_JERK 50.0000,EXAX_IGN 0}
DECL TQM_TQDAT_T TM47={T11 1,T12 10,T13 7,T14 8,T15 6,T16 1,T21 21264,T22 29204,T23 18968,T24 12162,T25 10154,T26
7920,K1 299,K2 301,K3 299,K4 309,K5 300,K6 300,O1 20,O2 30,ID 47,OVM 100,TMF 1.00000}
DECL E6POS XP179={X -918.871216,Y -698.759583,Z 535.541504,A -28.2911282,B 82.6727600,C -167.668503,S 2,T 10,E1 0.0,E2
0.0,E3 0.0,E4 0.0,E5 0.0,E6 0.0}
DECL FDAT FP179={TOOL_NO 10,BASE_NO 14,IPO_FRAME #BASE,POINT2[] " ",TQ_STATE TRUE}
DECL LDAT LCPDAT178={VEL 2.00000,ACC 100.000,APO_DIST 100.000,APO_FAC 50.0000,AXIS_VEL 100.000,AXIS_ACC
100.000,ORI_TYP #JOINT,CIRC_TYP #BASE,JERK_FAC 50.0000,GEAR_JERK 50.0000,EXAX_IGN 0}
DECL TQM_TQDAT_T TM48={T11 3,T12 8,T13 9,T14 6,T15 6,T16 4,T21 20290,T22 90858,T23 16040,T24 13122,T25 9569,T26
5951,K1 299,K2 301,K3 299,K4 309,K5 300,K6 300,O1 20,O2 30,ID 48,OVM 100,TMF 1.00000}
DECL E6POS XP180={X -898.824585,Y -641.393127,Z 534.317688,A -28.1345100,B 82.8552322,C -175.108810,S 2,T 10,E1 0.0,E2
0.0,E3 0.0,E4 0.0,E5 0.0,E6 0.0}
DECL FDAT FP180={TOOL_NO 10,BASE_NO 14,IPO_FRAME #BASE,POINT2[] " ",TQ_STATE TRUE}
DECL LDAT LCPDAT179={VEL 2.00000,ACC 100.000,APO_DIST 100.000,APO_FAC 50.0000,AXIS_VEL 100.000,AXIS_ACC
100.000,ORI_TYP #JOINT,CIRC_TYP #BASE,JERK_FAC 50.0000,GEAR_JERK 50.0000,EXAX_IGN 0}
DECL TQM_TQDAT_T TM49={T11 200,T12 200,T13 200,T14 200,T15 200,T16 200,T21 1000,T22 1000,T23 1000,T24 1000,T25
1000,T26 1000,K1 305,K2 307,K3 302,K4 303,K5 302,K6 305,O1 20,O2 30,ID 49,OVM 0,TMF 1.00000}
DECL E6POS XP181={X -887.245728,Y -584.034851,Z 532.159851,A -28.2267303,B 83.1098557,C 177.448242,S 2,T 10,E1 0.0,E2 0.0,E3
0.0,E4 0.0,E5 0.0,E6 0.0}
DECL FDAT FP181={TOOL_NO 10,BASE_NO 14,IPO_FRAME #BASE,POINT2[] " ",TQ_STATE TRUE}
DECL LDAT LCPDAT180={VEL 2.00000,ACC 100.000,APO_DIST 100.000,APO_FAC 50.0000,AXIS_VEL 100.000,AXIS_ACC
100.000,ORI_TYP #JOINT,CIRC_TYP #BASE,JERK_FAC 50.0000,GEAR_JERK 50.0000,EXAX_IGN 0}
DECL TQM_TQDAT_T TM50={T11 200,T12 200,T13 200,T14 200,T15 200,T16 200,T21 1000,T22 1000,T23 1000,T24 1000,T25
1000,T26 1000,K1 305,K2 307,K3 303,K4 303,K5 302,K6 305,O1 20,O2 30,ID 50,OVM 0,TMF 1.00000}
DECL E6POS XP182={X -878.628296,Y -525.898621,Z 529.659424,A -28.5416164,B 83.1298676,C 169.946259,S 2,T 10,E1 0.0,E2 0.0,E3
0.0,E4 0.0,E5 0.0,E6 0.0}
DECL FDAT FP182={TOOL_NO 10,BASE_NO 14,IPO_FRAME #BASE,POINT2[] " ",TQ_STATE TRUE}
DECL LDAT LCPDAT181={VEL 2.00000,ACC 100.000,APO_DIST 100.000,APO_FAC 50.0000,AXIS_VEL 100.000,AXIS_ACC
100.000,ORI_TYP #JOINT,CIRC_TYP #BASE,JERK_FAC 50.0000,GEAR_JERK 50.0000,EXAX_IGN 0}
DECL TQM_TQDAT_T TM51={T11 200,T12 200,T13 200,T14 200,T15 200,T16 200,T21 1000,T22 1000,T23 1000,T24 1000,T25
1000,T26 1000,K1 305,K2 307,K3 303,K4 303,K5 302,K6 305,O1 20,O2 30,ID 51,OVM 0,TMF 1.00000}
DECL E6POS XP183={X -926.118408,Y -692.729797,Z 534.390564,A -28.5827141,B 82.9060059,C -168.904785,S 2,T 10,E1 0.0,E2
0.0,E3 0.0,E4 0.0,E5 0.0,E6 0.0}
DECL FDAT FP183={TOOL_NO 10,BASE_NO 14,IPO_FRAME #BASE,POINT2[] " ",TQ_STATE TRUE}
DECL LDAT LCPDAT182={VEL 2.00000,ACC 100.000,APO_DIST 100.000,APO_FAC 50.0000,AXIS_VEL 100.000,AXIS_ACC
100.000,ORI_TYP #JOINT,CIRC_TYP #BASE,JERK_FAC 50.0000,GEAR_JERK 50.0000,EXAX_IGN 0}
DECL TQM_TQDAT_T TM52={T11 1,T12 0,T13 9,T14 4,T15 3,T16 1,T21 14059,T22 12126,T23 10222,T24 10591,T25 4856,T26
4824,K1 299,K2 301,K3 299,K4 309,K5 300,K6 300,O1 20,O2 30,ID 52,OVM 100,TMF 1.00000}
DECL E6POS XP184={X -930.387695,Y -689.272583,Z 533.733154,A -28.3559418,B 83.0562,C -169.431702,S 2,T 10,E1 0.0,E2 0.0,E3
0.0,E4 0.0,E5 0.0,E6 0.0}
DECL FDAT FP184={TOOL_NO 10,BASE_NO 14,IPO_FRAME #BASE,POINT2[] " ",TQ_STATE TRUE}
DECL LDAT LCPDAT183={VEL 2.00000,ACC 100.000,APO_DIST 100.000,APO_FAC 50.0000,AXIS_VEL 100.000,AXIS_ACC
100.000,ORI_TYP #JOINT,CIRC_TYP #BASE,JERK_FAC 50.0000,GEAR_JERK 50.0000,EXAX_IGN 0}
DECL TQM_TQDAT_T TM53={T11 0,T12 0,T13 0,T14 0,T15 0,T16 0,T21 0,T22 0,T23 0,T24 0,T25 0,T26 0,K1 299,K2 301,K3 299,K4
309,K5 300,K6 300,O1 20,O2 30,ID 53,OVM 100,TMF 1.00000}

```

```

DECL E6POS XP185={X -933.625427,Y -686.778687,Z 533.242065,A -28.3559551,B 83.0562439,C -170.816483,S 2,T 10,E1 0.0,E2
0.0,E3 0.0,E4 0.0,E5 0.0,E6 0.0}
DECL FDAT FP185={TOOL_NO 10,BASE_NO 14,IPO_FRAME #BASE,POINT2[] " ",TQ_STATE TRUE}
DECL LDAT LCPDAT184={VEL 2.00000,ACC 100.000,APO_DIST 100.000,APO_FAC 50.0000,AXIS_VEL 100.000,AXIS_ACC
100.000,ORI_TYP #JOINT,CIRC_TYP #BASE,JERK_FAC 50.0000,GEAR_JERK 50.0000,EXAX_IGN 0}
DECL TQM_TQDAT_T TM54={T11 1,T12 5,T13 8,T14 3,T15 6,T16 0,T21 7561,T22 47129,T23 7004,T24 11211,T25 8465,T26 4603,K1
299,K2 301,K3 299,K4 309,K5 300,K6 300,O1 20,O2 30,ID 54,OVM 100,TMF 1.00000}
DECL E6POS XP186={X -933.625488,Y -686.778687,Z 533.242126,A -28.3559628,B 83.0562592,C -171.435150,S 2,T 10,E1 0.0,E2
0.0,E3 0.0,E4 0.0,E5 0.0,E6 0.0}
DECL FDAT FP186={TOOL_NO 10,BASE_NO 14,IPO_FRAME #BASE,POINT2[] " ",TQ_STATE TRUE}
DECL LDAT LCPDAT185={VEL 2.00000,ACC 100.000,APO_DIST 100.000,APO_FAC 50.0000,AXIS_VEL 100.000,AXIS_ACC
100.000,ORI_TYP #JOINT,CIRC_TYP #BASE,JERK_FAC 50.0000,GEAR_JERK 50.0000,EXAX_IGN 0}
DECL TQM_TQDAT_T TM55={T11 1,T12 10,T13 8,T14 6,T15 6,T16 0,T21 14610,T22 65727,T23 9933,T24 13582,T25 8465,T26
4603,K1 299,K2 301,K3 299,K4 309,K5 300,K6 300,O1 20,O2 30,ID 55,OVM 100,TMF 1.00000}
DECL E6POS XP187={X -918.880859,Y -658.865540,Z 533.204,A -23.7944660,B 82.9911652,C -171.141205,S 2,T 10,E1 0.0,E2 0.0,E3
0.0,E4 0.0,E5 0.0,E6 0.0}
DECL FDAT FP187={TOOL_NO 10,BASE_NO 14,IPO_FRAME #BASE,POINT2[] " ",TQ_STATE TRUE}
DECL LDAT LCPDAT186={VEL 2.00000,ACC 100.000,APO_DIST 100.000,APO_FAC 50.0000,AXIS_VEL 100.000,AXIS_ACC
100.000,ORI_TYP #JOINT,CIRC_TYP #BASE,JERK_FAC 50.0000,GEAR_JERK 50.0000,EXAX_IGN 0}
DECL TQM_TQDAT_T TM56={T11 200,T12 200,T13 200,T14 200,T15 200,T16 200,T21 1000,T22 1000,T23 1000,T24 1000,T25
1000,T26 1000,K1 305,K2 307,K3 302,K4 303,K5 302,K6 305,O1 20,O2 30,ID 56,OVM 0,TMF 1.00000}
DECL E6POS XP188={X -922.344,Y -667.508240,Z 533.327454,A -28.3548584,B 83.0536499,C -174.744904,S 2,T 10,E1 0.0,E2 0.0,E3
0.0,E4 0.0,E5 0.0,E6 0.0}
DECL FDAT FP188={TOOL_NO 10,BASE_NO 14,IPO_FRAME #BASE,POINT2[] " ",TQ_STATE TRUE}
DECL LDAT LCPDAT187={VEL 2.00000,ACC 100.000,APO_DIST 100.000,APO_FAC 50.0000,AXIS_VEL 100.000,AXIS_ACC
100.000,ORI_TYP #JOINT,CIRC_TYP #BASE,JERK_FAC 50.0000,GEAR_JERK 50.0000,EXAX_IGN 0}
DECL TQM_TQDAT_T TM57={T11 2,T12 8,T13 7,T14 5,T15 7,T16 1,T21 15929,T22 15533,T23 4682,T24 15404,T25 8821,T26 7263,K1
299,K2 301,K3 299,K4 309,K5 300,K6 300,O1 20,O2 30,ID 57,OVM 100,TMF 1.00000}
DECL E6POS XP189={X -903.530396,Y -619.635,Z 531.022034,A -28.3443546,B 83.0322189,C 178.745972,S 2,T 10,E1 0.0,E2 0.0,E3
0.0,E4 0.0,E5 0.0,E6 0.0}
DECL FDAT FP189={TOOL_NO 10,BASE_NO 14,IPO_FRAME #BASE,POINT2[] " ",TQ_STATE TRUE}
DECL LDAT LCPDAT188={VEL 2.00000,ACC 100.000,APO_DIST 100.000,APO_FAC 50.0000,AXIS_VEL 100.000,AXIS_ACC
100.000,ORI_TYP #JOINT,CIRC_TYP #BASE,JERK_FAC 50.0000,GEAR_JERK 50.0000,EXAX_IGN 0}
DECL TQM_TQDAT_T TM58={T11 200,T12 200,T13 200,T14 200,T15 200,T16 200,T21 1000,T22 1000,T23 1000,T24 1000,T25
1000,T26 1000,K1 305,K2 307,K3 303,K4 303,K5 303,K6 305,O1 20,O2 30,ID 58,OVM 0,TMF 1.00000}
DECL E6POS XP190={X -915.006531,Y -652.465759,Z 533.240601,A -28.4041290,B 82.9397125,C -177.285080,S 2,T 10,E1 0.0,E2
0.0,E3 0.0,E4 0.0,E5 0.0,E6 0.0}
DECL FDAT FP190={TOOL_NO 10,BASE_NO 14,IPO_FRAME #BASE,POINT2[] " ",TQ_STATE TRUE}
DECL LDAT LCPDAT189={VEL 2.00000,ACC 100.000,APO_DIST 100.000,APO_FAC 50.0000,AXIS_VEL 100.000,AXIS_ACC
100.000,ORI_TYP #JOINT,CIRC_TYP #BASE,JERK_FAC 50.0000,GEAR_JERK 50.0000,EXAX_IGN 0}
DECL TQM_TQDAT_T TM59={T11 2,T12 9,T13 7,T14 6,T15 7,T16 2,T21 16615,T22 14945,T23 5024,T24 6098,T25 7966,T26 5771,K1
299,K2 301,K3 299,K4 309,K5 300,K6 300,O1 20,O2 30,ID 59,OVM 100,TMF 1.00000}
DECL E6POS XP191={X -900.756897,Y -618.380859,Z 532.738770,A -28.3977413,B 82.9272766,C 177.606644,S 2,T 10,E1 0.0,E2 0.0,E3
0.0,E4 0.0,E5 0.0,E6 0.0}
DECL FDAT FP191={TOOL_NO 10,BASE_NO 14,IPO_FRAME #BASE,POINT2[] " ",TQ_STATE TRUE}
DECL LDAT LCPDAT190={VEL 2.00000,ACC 100.000,APO_DIST 100.000,APO_FAC 50.0000,AXIS_VEL 100.000,AXIS_ACC
100.000,ORI_TYP #JOINT,CIRC_TYP #BASE,JERK_FAC 50.0000,GEAR_JERK 50.0000,EXAX_IGN 0}
DECL TQM_TQDAT_T TM60={T11 200,T12 200,T13 200,T14 200,T15 200,T16 200,T21 1000,T22 1000,T23 1000,T24 1000,T25
1000,T26 1000,K1 305,K2 307,K3 303,K4 303,K5 302,K6 305,O1 20,O2 30,ID 60,OVM 0,TMF 1.00000}
DECL E6POS XP192={X -905.388306,Y -635.492249,Z 533.270874,A -28.4014397,B 82.9347382,C 179.772736,S 2,T 10,E1 0.0,E2 0.0,E3
0.0,E4 0.0,E5 0.0,E6 0.0}
DECL FDAT FP192={TOOL_NO 10,BASE_NO 14,IPO_FRAME #BASE,POINT2[] " ",TQ_STATE TRUE}
DECL LDAT LCPDAT191={VEL 2.00000,ACC 100.000,APO_DIST 100.000,APO_FAC 50.0000,AXIS_VEL 100.000,AXIS_ACC
100.000,ORI_TYP #JOINT,CIRC_TYP #BASE,JERK_FAC 50.0000,GEAR_JERK 50.0000,EXAX_IGN 0}
DECL TQM_TQDAT_T TM61={T11 1,T12 8,T13 8,T14 7,T15 8,T16 2,T21 9400,T22 10814,T23 4618,T24 11672,T25 5490,T26 4750,K1
299,K2 301,K3 298,K4 309,K5 300,K6 300,O1 20,O2 30,ID 61,OVM 100,TMF 1.00000}
DECL E6POS XP193={X -881.610779,Y -512.249,Z 529.826355,A -22.3238049,B 82.8622284,C 170.329376,S 2,T 10,E1 0.0,E2 0.0,E3
0.0,E4 0.0,E5 0.0,E6 0.0}
DECL FDAT FP193={TOOL_NO 10,BASE_NO 14,IPO_FRAME #BASE,POINT2[] " ",TQ_STATE TRUE}
DECL LDAT LCPDAT192={VEL 2.00000,ACC 100.000,APO_DIST 100.000,APO_FAC 50.0000,AXIS_VEL 100.000,AXIS_ACC
100.000,ORI_TYP #JOINT,CIRC_TYP #BASE,JERK_FAC 50.0000,GEAR_JERK 50.0000,EXAX_IGN 0}
DECL TQM_TQDAT_T TM62={T11 200,T12 200,T13 200,T14 200,T15 200,T16 200,T21 1000,T22 1000,T23 1000,T24 1000,T25
1000,T26 1000,K1 305,K2 307,K3 303,K4 304,K5 303,K6 305,O1 20,O2 30,ID 62,OVM 0,TMF 1.00000}
DECL E6POS XP194={X -900.338440,Y -627.189514,Z 533.329224,A -28.3294506,B 82.6316528,C 178.221527,S 2,T 10,E1 0.0,E2 0.0,E3
0.0,E4 0.0,E5 0.0,E6 0.0}
DECL FDAT FP194={TOOL_NO 10,BASE_NO 14,IPO_FRAME #BASE,POINT2[] " ",TQ_STATE TRUE}
DECL LDAT LCPDAT193={VEL 2.00000,ACC 100.000,APO_DIST 100.000,APO_FAC 50.0000,AXIS_VEL 100.000,AXIS_ACC
100.000,ORI_TYP #JOINT,CIRC_TYP #BASE,JERK_FAC 50.0000,GEAR_JERK 50.0000,EXAX_IGN 0}
DECL TQM_TQDAT_T TM63={T11 1,T12 7,T13 9,T14 7,T15 8,T16 2,T21 11242,T22 10552,T23 3312,T24 11865,T25 4758,T26 4746,K1
299,K2 301,K3 298,K4 309,K5 300,K6 300,O1 20,O2 30,ID 63,OVM 100,TMF 1.00000}
DECL E6POS XP195={X -893.748047,Y -615.354675,Z 533.343384,A -28.2911015,B 82.5579071,C 175.921082,S 2,T 10,E1 0.0,E2 0.0,E3
0.0,E4 0.0,E5 0.0,E6 0.0}
DECL FDAT FP195={TOOL_NO 10,BASE_NO 14,IPO_FRAME #BASE,POINT2[] " ",TQ_STATE TRUE}
DECL LDAT LCPDAT194={VEL 2.00000,ACC 100.000,APO_DIST 100.000,APO_FAC 50.0000,AXIS_VEL 100.000,AXIS_ACC
100.000,ORI_TYP #JOINT,CIRC_TYP #BASE,JERK_FAC 50.0000,GEAR_JERK 50.0000,EXAX_IGN 0}

```

```

DECL TQM_TQDAT_T TM64={T11 1,T12 5,T13 9,T14 9,T15 14,T16 2,T21 11346,T22 15790,T23 3485,T24 18593,T25 11938,T26
5061,K1 299,K2 301,K3 298,K4 309,K5 300,K6 300,O1 20,O2 30,ID 64,OVM 100,TMF 1.00000}
DECL E6POS XP196={X -885.178650,Y -591.717896,Z 532.833,A -28.2895222,B 82.5491791,C 172.370163,S 2,T 10,E1 0.0,E2 0.0,E3
0.0,E4 0.0,E5 0.0,E6 0.0}
DECL FDAT FP196={TOOL_NO 10,BASE_NO 14,IPO_FRAME #BASE,POINT2[] " ",TQ_STATE TRUE}
DECL LDAT LCPDAT195={VEL 2.00000,ACC 100.000,APO_DIST 100.000,APO_FAC 50.0000,AXIS_VEL 100.000,AXIS_ACC
100.000,ORI_TYP #JOINT,CIRC_TYP #BASE,JERK_FAC 50.0000,GEAR_JERK 50.0000,EXAX_IGN 0}
DECL TQM_TQDAT_T TM65={T11 200,T12 200,T13 200,T14 200,T15 200,T16 200,T21 1000,T22 1000,T23 1000,T24 1000,T25
1000,T26 1000,K1 305,K2 307,K3 303,K4 304,K5 302,K6 305,O1 20,O2 30,ID 65,OVM 0,TMF 1.00000}
DECL E6POS XP197={X -888.094482,Y -599.761353,Z 533.006592,A -28.0797520,B 82.5574112,C 173.532913,S 2,T 10,E1 0.0,E2 0.0,E3
0.0,E4 0.0,E5 0.0,E6 0.0}
DECL FDAT FP197={TOOL_NO 10,BASE_NO 14,IPO_FRAME #BASE,POINT2[] " ",TQ_STATE TRUE}
DECL LDAT LCPDAT196={VEL 2.00000,ACC 100.000,APO_DIST 100.000,APO_FAC 50.0000,AXIS_VEL 100.000,AXIS_ACC
100.000,ORI_TYP #JOINT,CIRC_TYP #BASE,JERK_FAC 50.0000,GEAR_JERK 50.0000,EXAX_IGN 0}
DECL TQM_TQDAT_T TM66={T11 200,T12 200,T13 200,T14 200,T15 200,T16 200,T21 1000,T22 1000,T23 1000,T24 1000,T25
1000,T26 1000,K1 305,K2 307,K3 303,K4 304,K5 303,K6 305,O1 20,O2 30,ID 66,OVM 0,TMF 1.00000}
DECL E6POS XP198={X -888.094482,Y -599.761353,Z 533.006592,A -28.2023010,B 82.6948624,C 173.411377,S 2,T 10,E1 0.0,E2 0.0,E3
0.0,E4 0.0,E5 0.0,E6 0.0}
DECL FDAT FP198={TOOL_NO 10,BASE_NO 14,IPO_FRAME #BASE,POINT2[] " ",TQ_STATE TRUE}
DECL LDAT LCPDAT197={VEL 2.00000,ACC 100.000,APO_DIST 100.000,APO_FAC 50.0000,AXIS_VEL 100.000,AXIS_ACC
100.000,ORI_TYP #JOINT,CIRC_TYP #BASE,JERK_FAC 50.0000,GEAR_JERK 50.0000,EXAX_IGN 0}
DECL TQM_TQDAT_T TM67={T11 1,T12 6,T13 8,T14 10,T15 8,T16 2,T21 10949,T22 19201,T23 13920,T24 17200,T25 5426,T26
4632,K1 299,K2 301,K3 298,K4 309,K5 300,K6 300,O1 20,O2 30,ID 67,OVM 100,TMF 1.00000}
DECL E6POS XP199={X -880.767395,Y -588.406128,Z 531.963623,A -28.2023,B 82.6948318,C 171.254150,S 2,T 10,E1 0.0,E2 0.0,E3
0.0,E4 0.0,E5 0.0,E6 0.0}
DECL FDAT FP199={TOOL_NO 10,BASE_NO 14,IPO_FRAME #BASE,POINT2[] " ",TQ_STATE TRUE}
DECL LDAT LCPDAT198={VEL 2.00000,ACC 100.000,APO_DIST 100.000,APO_FAC 50.0000,AXIS_VEL 100.000,AXIS_ACC
100.000,ORI_TYP #JOINT,CIRC_TYP #BASE,JERK_FAC 50.0000,GEAR_JERK 50.0000,EXAX_IGN 0}
DECL TQM_TQDAT_T TM68={T11 1,T12 7,T13 9,T14 8,T15 7,T16 2,T21 14404,T22 11228,T23 8586,T24 11541,T25 6845,T26 3845,K1
299,K2 301,K3 298,K4 309,K5 300,K6 300,O1 20,O2 30,ID 68,OVM 100,TMF 1.00000}
DECL E6POS XP200={X -871.865112,Y -579.384460,Z 532.423,A -28.2023144,B 82.6948700,C 169.370209,S 2,T 10,E1 0.0,E2 0.0,E3
0.0,E4 0.0,E5 0.0,E6 0.0}
DECL FDAT FP200={TOOL_NO 10,BASE_NO 14,IPO_FRAME #BASE,POINT2[] " ",TQ_STATE TRUE}
DECL LDAT LCPDAT199={VEL 2.00000,ACC 100.000,APO_DIST 100.000,APO_FAC 50.0000,AXIS_VEL 100.000,AXIS_ACC
100.000,ORI_TYP #JOINT,CIRC_TYP #BASE,JERK_FAC 50.0000,GEAR_JERK 50.0000,EXAX_IGN 0}
DECL TQM_TQDAT_T TM69={T11 1,T12 9,T13 7,T14 7,T15 6,T16 2,T21 6934,T22 6761,T23 3500,T24 16972,T25 5397,T26 1476,K1
299,K2 301,K3 298,K4 309,K5 300,K6 300,O1 20,O2 30,ID 69,OVM 100,TMF 1.00000}
DECL E6POS XP201={X -854.509277,Y -584.758850,Z 534.718567,A -27.6458607,B 82.3194427,C 169.184433,S 2,T 10,E1 0.0,E2 0.0,E3
0.0,E4 0.0,E5 0.0,E6 0.0}
DECL FDAT FP201={TOOL_NO 10,BASE_NO 14,IPO_FRAME #BASE,POINT2[] " ",TQ_STATE TRUE}
DECL LDAT LCPDAT200={VEL 2.00000,ACC 100.000,APO_DIST 100.000,APO_FAC 50.0000,AXIS_VEL 100.000,AXIS_ACC
100.000,ORI_TYP #JOINT,CIRC_TYP #BASE,JERK_FAC 50.0000,GEAR_JERK 50.0000,EXAX_IGN 0}
DECL TQM_TQDAT_T TM70={T11 1,T12 9,T13 8,T14 8,T15 6,T16 3,T21 10832,T22 17264,T23 5373,T24 16972,T25 5397,T26 4926,K1
299,K2 301,K3 298,K4 309,K5 300,K6 301,O1 20,O2 30,ID 70,OVM 100,TMF 1.00000}
DECL E6POS XP202={X -816.853,Y -596.084595,Z 539.913086,A -27.6451283,B 82.3190842,C 168.170837,S 2,T 10,E1 0.0,E2 0.0,E3
0.0,E4 0.0,E5 0.0,E6 0.0}
DECL FDAT FP202={TOOL_NO 10,BASE_NO 14,IPO_FRAME #BASE,POINT2[] " ",TQ_STATE TRUE}
DECL LDAT LCPDAT201={VEL 2.00000,ACC 100.000,APO_DIST 100.000,APO_FAC 50.0000,AXIS_VEL 100.000,AXIS_ACC
100.000,ORI_TYP #JOINT,CIRC_TYP #BASE,JERK_FAC 50.0000,GEAR_JERK 50.0000,EXAX_IGN 0}
DECL TQM_TQDAT_T TM71={T11 2,T12 9,T13 8,T14 7,T15 6,T16 4,T21 18468,T22 18606,T23 3884,T24 7509,T25 4253,T26 4475,K1
299,K2 301,K3 298,K4 309,K5 300,K6 301,O1 20,O2 30,ID 71,OVM 100,TMF 1.00000}
DECL E6POS XP203={X -886.895691,Y -278.706390,Z 461.700684,A -68.0859528,B 87.4909668,C 89.3640060,S 2,T 10,E1 0.0,E2 0.0,E3
0.0,E4 0.0,E5 0.0,E6 0.0}
DECL FDAT FP203={TOOL_NO 10,BASE_NO 14,IPO_FRAME #BASE,POINT2[] " ",TQ_STATE TRUE}
DECL LDAT LCPDAT202={VEL 2.00000,ACC 100.000,APO_DIST 100.000,APO_FAC 50.0000,AXIS_VEL 100.000,AXIS_ACC
100.000,ORI_TYP #JOINT,CIRC_TYP #BASE,JERK_FAC 50.0000,GEAR_JERK 50.0000,EXAX_IGN 0}
DECL TQM_TQDAT_T TM72={T11 200,T12 200,T13 200,T14 200,T15 200,T16 200,T21 1000,T22 1000,T23 1000,T24 1000,T25
1000,T26 1000,K1 305,K2 307,K3 303,K4 303,K5 303,K6 305,O1 20,O2 30,ID 72,OVM 0,TMF 1.00000}
DECL E6POS XP204={X -784.443298,Y -651.910217,Z 547.094238,A -27.6294575,B 82.2971191,C 163.297,S 2,T 10,E1 0.0,E2 0.0,E3
0.0,E4 0.0,E5 0.0,E6 0.0}
DECL FDAT FP204={TOOL_NO 10,BASE_NO 14,IPO_FRAME #BASE,POINT2[] " ",TQ_STATE TRUE}
DECL LDAT LCPDAT203={VEL 2.00000,ACC 100.000,APO_DIST 100.000,APO_FAC 50.0000,AXIS_VEL 100.000,AXIS_ACC
100.000,ORI_TYP #JOINT,CIRC_TYP #BASE,JERK_FAC 50.0000,GEAR_JERK 50.0000,EXAX_IGN 0}
DECL TQM_TQDAT_T TM73={T11 5,T12 7,T13 9,T14 7,T15 6,T16 3,T21 30686,T22 26016,T23 7780,T24 12729,T25 8320,T26 6101,K1
299,K2 301,K3 298,K4 309,K5 300,K6 301,O1 20,O2 30,ID 73,OVM 100,TMF 1.00000}
DECL E6POS XP205={X -879.337219,Y -289.076508,Z 502.215118,A -27.6308594,B 82.2941666,C 127.354576,S 2,T 10,E1 0.0,E2 0.0,E3
0.0,E4 0.0,E5 0.0,E6 0.0}
DECL FDAT FP205={TOOL_NO 10,BASE_NO 14,IPO_FRAME #BASE,POINT2[] " ",TQ_STATE TRUE}
DECL LDAT LCPDAT204={VEL 2.00000,ACC 100.000,APO_DIST 100.000,APO_FAC 50.0000,AXIS_VEL 100.000,AXIS_ACC
100.000,ORI_TYP #JOINT,CIRC_TYP #BASE,JERK_FAC 50.0000,GEAR_JERK 50.0000,EXAX_IGN 0}
DECL TQM_TQDAT_T TM74={T11 4,T12 6,T13 7,T14 11,T15 3,T16 6,T21 17965,T22 38200,T23 10401,T24 18512,T25 11641,T26
8954,K1 299,K2 301,K3 299,K4 309,K5 300,K6 301,O1 20,O2 30,ID 74,OVM 100,TMF 1.00000}
DECL E6POS XP206={X -915.309143,Y -261.591919,Z 496.171600,A -27.6305618,B 82.2941284,C 127.354889,S 2,T 10,E1 0.0,E2 0.0,E3
0.0,E4 0.0,E5 0.0,E6 0.0}
DECL FDAT FP206={TOOL_NO 10,BASE_NO 14,IPO_FRAME #BASE,POINT2[] " ",TQ_STATE TRUE}

```

```

DECL LDAT LCPDAT205={VEL 2.00000,ACC 100.000,APO_DIST 100.000,APO_FAC 50.0000,AXIS_VEL 100.000,AXIS_ACC
100.000,ORI_TYP #JOINT,CIRC_TYP #BASE,JERK_FAC 50.0000,GEAR_JERK 50.0000,EXAX_IGN 0}
DECL TQM_TQDAT_T TM75={T11 1,T12 4,T13 5,T14 8,T15 4,T16 3,T21 25821,T22 12655,T23 4520,T24 2415,T25 24330,T26 6397,K1
299,K2 301,K3 299,K4 309,K5 300,K6 301,O1 20,O2 30,ID 75,OVM 100,TMF 1.00000}
DECL E6POS XP207={X -939.827087,Y -247.739594,Z 492.361328,A -27.6304626,B 82.2941208,C 126.905716,S 2,T 10,E1 0.0,E2 0.0,E3
0.0,E4 0.0,E5 0.0,E6 0.0}
DECL FDAT FP207={TOOL_NO 10,BASE_NO 14,IPO_FRAME #BASE,POINT2[] " ",TQ_STATE TRUE}
DECL LDAT LCPDAT206={VEL 2.00000,ACC 100.000,APO_DIST 100.000,APO_FAC 50.0000,AXIS_VEL 100.000,AXIS_ACC
100.000,ORI_TYP #JOINT,CIRC_TYP #BASE,JERK_FAC 50.0000,GEAR_JERK 50.0000,EXAX_IGN 0}
DECL TQM_TQDAT_T TM76={T11 0,T12 5,T13 6,T14 22,T15 0,T16 2,T21 5088,T22 23012,T23 9260,T24 23034,T25 5454,T26 7372,K1
299,K2 301,K3 299,K4 309,K5 300,K6 301,O1 20,O2 30,ID 76,OVM 100,TMF 1.00000}
DECL E6POS XP208={X -943.970520,Y -249.627823,Z 491.983093,A -27.6304626,B 82.2941208,C 128.122360,S 2,T 10,E1 0.0,E2 0.0,E3
0.0,E4 0.0,E5 0.0,E6 0.0}
DECL FDAT FP208={TOOL_NO 10,BASE_NO 14,IPO_FRAME #BASE,POINT2[] " ",TQ_STATE TRUE}
DECL LDAT LCPDAT207={VEL 2.00000,ACC 100.000,APO_DIST 100.000,APO_FAC 50.0000,AXIS_VEL 100.000,AXIS_ACC
100.000,ORI_TYP #JOINT,CIRC_TYP #BASE,JERK_FAC 50.0000,GEAR_JERK 50.0000,EXAX_IGN 0}
DECL TQM_TQDAT_T TM77={T11 0,T12 13,T13 6,T14 11,T15 5,T16 9,T21 6403,T22 83527,T23 28304,T24 29177,T25 11116,T26
32477,K1 299,K2 301,K3 299,K4 309,K5 300,K6 301,O1 20,O2 30,ID 77,OVM 100,TMF 1.00000}
DECL E6POS XP209={X -947.377258,Y -251.078156,Z 491.677399,A -28.6737785,B 82.4067,C 128.511200,S 2,T 10,E1 0.0,E2 0.0,E3
0.0,E4 0.0,E5 0.0,E6 0.0}
DECL FDAT FP209={TOOL_NO 10,BASE_NO 14,IPO_FRAME #BASE,POINT2[] " ",TQ_STATE TRUE}
DECL LDAT LCPDAT208={VEL 2.00000,ACC 100.000,APO_DIST 100.000,APO_FAC 50.0000,AXIS_VEL 100.000,AXIS_ACC
100.000,ORI_TYP #JOINT,CIRC_TYP #BASE,JERK_FAC 50.0000,GEAR_JERK 50.0000,EXAX_IGN 0}
DECL TQM_TQDAT_T TM78={T11 1,T12 15,T13 6,T14 11,T15 5,T16 9,T21 19861,T22 83527,T23 28304,T24 29177,T25 11116,T26
32477,K1 299,K2 301,K3 299,K4 309,K5 300,K6 301,O1 20,O2 30,ID 78,OVM 100,TMF 1.00000}
DECL E6POS XP210={X -942.547485,Y -259.492279,Z 492.780548,A -29.2640972,B 82.4730835,C 130.229294,S 2,T 10,E1 0.0,E2 0.0,E3
0.0,E4 0.0,E5 0.0,E6 0.0}
DECL FDAT FP210={TOOL_NO 10,BASE_NO 14,IPO_FRAME #BASE,POINT2[] " ",TQ_STATE TRUE}
DECL LDAT LCPDAT209={VEL 2.00000,ACC 100.000,APO_DIST 100.000,APO_FAC 50.0000,AXIS_VEL 100.000,AXIS_ACC
100.000,ORI_TYP #JOINT,CIRC_TYP #BASE,JERK_FAC 50.0000,GEAR_JERK 50.0000,EXAX_IGN 0}
DECL TQM_TQDAT_T TM79={T11 1,T12 14,T13 6,T14 8,T15 6,T16 3,T21 19508,T22 45145,T23 6176,T24 3725,T25 8437,T26 6192,K1
299,K2 301,K3 299,K4 309,K5 300,K6 301,O1 20,O2 30,ID 79,OVM 100,TMF 1.00000}
DECL E6POS XP211={X -876.754089,Y -380.063263,Z 508.105225,A -29.2612362,B 82.4724884,C 148.454285,S 2,T 10,E1 0.0,E2 0.0,E3
0.0,E4 0.0,E5 0.0,E6 0.0}
DECL FDAT FP211={TOOL_NO 10,BASE_NO 14,IPO_FRAME #BASE,POINT2[] " ",TQ_STATE TRUE}
DECL LDAT LCPDAT210={VEL 2.00000,ACC 100.000,APO_DIST 100.000,APO_FAC 50.0000,AXIS_VEL 100.000,AXIS_ACC
100.000,ORI_TYP #JOINT,CIRC_TYP #BASE,JERK_FAC 50.0000,GEAR_JERK 50.0000,EXAX_IGN 0}
DECL TQM_TQDAT_T TM80={T11 200,T12 200,T13 200,T14 200,T15 200,T16 200,T21 1000,T22 1000,T23 1000,T24 1000,T25
1000,T26 1000,K1 305,K2 307,K3 303,K4 303,K5 303,K6 305,O1 20,O2 30,ID 80,OVM 0,TMF 1.00000}
DECL E6POS XP212={X -912.161194,Y -320.145752,Z 500.184601,A -31.8239803,B 82.3473129,C 137.131027,S 2,T 10,E1 0.0,E2 0.0,E3
0.0,E4 0.0,E5 0.0,E6 0.0}
DECL FDAT FP212={TOOL_NO 10,BASE_NO 14,IPO_FRAME #BASE,POINT2[] " ",TQ_STATE TRUE}
DECL LDAT LCPDAT211={VEL 2.00000,ACC 100.000,APO_DIST 100.000,APO_FAC 50.0000,AXIS_VEL 100.000,AXIS_ACC
100.000,ORI_TYP #JOINT,CIRC_TYP #BASE,JERK_FAC 50.0000,GEAR_JERK 50.0000,EXAX_IGN 0}
DECL TQM_TQDAT_T TM81={T11 0,T12 10,T13 7,T14 10,T15 2,T16 4,T21 9322,T22 6609,T23 7320,T24 2904,T25 11832,T26 6857,K1
299,K2 301,K3 299,K4 309,K5 300,K6 301,O1 20,O2 30,ID 81,OVM 100,TMF 1.00000}
DECL E6POS XP213={X -904.716187,Y -332.571594,Z 501.915070,A -31.8239861,B 82.3473129,C 139.780334,S 2,T 10,E1 0.0,E2 0.0,E3
0.0,E4 0.0,E5 0.0,E6 0.0}
DECL FDAT FP213={TOOL_NO 10,BASE_NO 14,IPO_FRAME #BASE,POINT2[] " ",TQ_STATE TRUE}
DECL LDAT LCPDAT212={VEL 2.00000,ACC 100.000,APO_DIST 100.000,APO_FAC 50.0000,AXIS_VEL 100.000,AXIS_ACC
100.000,ORI_TYP #JOINT,CIRC_TYP #BASE,JERK_FAC 50.0000,GEAR_JERK 50.0000,EXAX_IGN 0}
DECL TQM_TQDAT_T TM82={T11 1,T12 10,T13 8,T14 10,T15 5,T16 4,T21 11466,T22 9326,T23 7320,T24 4345,T25 11832,T26
6857,K1 299,K2 301,K3 299,K4 309,K5 300,K6 301,O1 20,O2 30,ID 82,OVM 100,TMF 1.00000}
DECL E6POS XP214={X -894.338623,Y -363.731506,Z 505.316650,A -32.6262474,B 82.4918,C 143.380386,S 2,T 10,E1 0.0,E2 0.0,E3
0.0,E4 0.0,E5 0.0,E6 0.0}
DECL FDAT FP214={TOOL_NO 10,BASE_NO 14,IPO_FRAME #BASE,POINT2[] " ",TQ_STATE TRUE}
DECL LDAT LCPDAT213={VEL 2.00000,ACC 100.000,APO_DIST 100.000,APO_FAC 50.0000,AXIS_VEL 100.000,AXIS_ACC
100.000,ORI_TYP #JOINT,CIRC_TYP #BASE,JERK_FAC 50.0000,GEAR_JERK 50.0000,EXAX_IGN 0}
DECL TQM_TQDAT_T TM83={T11 2,T12 11,T13 8,T14 9,T15 5,T16 5,T21 22941,T22 24327,T23 8395,T24 7924,T25 6084,T26 4593,K1
299,K2 301,K3 299,K4 309,K5 300,K6 301,O1 20,O2 30,ID 83,OVM 100,TMF 1.00000}
DECL E6POS XP215={X -885.640930,Y -383.467590,Z 507.684326,A -34.2188454,B 82.7934799,C 145.149170,S 2,T 10,E1 0.0,E2 0.0,E3
0.0,E4 0.0,E5 0.0,E6 0.0}
DECL FDAT FP215={TOOL_NO 10,BASE_NO 14,IPO_FRAME #BASE,POINT2[] " ",TQ_STATE TRUE}
DECL LDAT LCPDAT214={VEL 2.00000,ACC 100.000,APO_DIST 100.000,APO_FAC 50.0000,AXIS_VEL 100.000,AXIS_ACC
100.000,ORI_TYP #JOINT,CIRC_TYP #BASE,JERK_FAC 50.0000,GEAR_JERK 50.0000,EXAX_IGN 0}
DECL TQM_TQDAT_T TM84={T11 1,T12 8,T13 8,T14 6,T15 5,T16 4,T21 7543,T22 8546,T23 3307,T24 4749,T25 4514,T26 2417,K1
299,K2 301,K3 299,K4 309,K5 300,K6 301,O1 20,O2 30,ID 84,OVM 100,TMF 1.00000}
DECL E6POS XP216={X -880.465759,Y -402.092438,Z 509.543732,A -35.0502815,B 82.9562149,C 147.458313,S 2,T 10,E1 0.0,E2 0.0,E3
0.0,E4 0.0,E5 0.0,E6 0.0}
DECL FDAT FP216={TOOL_NO 10,BASE_NO 14,IPO_FRAME #BASE,POINT2[] " ",TQ_STATE TRUE}
DECL LDAT LCPDAT215={VEL 2.00000,ACC 100.000,APO_DIST 100.000,APO_FAC 50.0000,AXIS_VEL 100.000,AXIS_ACC
100.000,ORI_TYP #JOINT,CIRC_TYP #BASE,JERK_FAC 50.0000,GEAR_JERK 50.0000,EXAX_IGN 0}
DECL TQM_TQDAT_T TM85={T11 1,T12 10,T13 8,T14 7,T15 5,T16 5,T21 12317,T22 18775,T23 6581,T24 6845,T25 6041,T26 4498,K1
299,K2 301,K3 299,K4 309,K5 300,K6 301,O1 20,O2 30,ID 85,OVM 100,TMF 1.00000}

```



```

DECL E6POS XP217={X -866.741943,Y -422.377472,Z 512.371460,A -35.0502892,B 82.9562149,C 150.872681,S 2,T 10,E1 0.0,E2 0.0,E3
0.0,E4 0.0,E5 0.0,E6 0.0}
DECL FDAT FP217={TOOL_NO 10,BASE_NO 14,IPO_FRAME #BASE,POINT2[] " ",TQ_STATE TRUE}
DECL LDAT LCPDAT216={VEL 2.00000,ACC 100.000,APO_DIST 100.000,APO_FAC 50.0000,AXIS_VEL 100.000,AXIS_ACC
100.000,ORI_TYP #JOINT,CIRC_TYP #BASE,JERK_FAC 50.0000,GEAR_JERK 50.0000,EXAX_IGN 0}
DECL TQM_TQDAT_T TM86={T11 2,T12 10,T13 8,T14 6,T15 5,T16 5,T21 11989,T22 18180,T23 6394,T24 9057,T25 7397,T26 5096,K1
299,K2 301,K3 299,K4 309,K5 300,K6 301,O1 20,O2 30,ID 86,OVM 100,TFM 1.00000}
DECL E6POS XP218={X -841.553406,Y -424.976044,Z 515.166382,A -34.0047379,B 82.7133865,C 152.523514,S 2,T 10,E1 0.0,E2 0.0,E3
0.0,E4 0.0,E5 0.0,E6 0.0}
DECL FDAT FP218={TOOL_NO 10,BASE_NO 14,IPO_FRAME #BASE,POINT2[] " ",TQ_STATE TRUE}
DECL LDAT LCPDAT217={VEL 2.00000,ACC 100.000,APO_DIST 100.000,APO_FAC 50.0000,AXIS_VEL 100.000,AXIS_ACC
100.000,ORI_TYP #JOINT,CIRC_TYP #BASE,JERK_FAC 50.0000,GEAR_JERK 50.0000,EXAX_IGN 0}
DECL TQM_TQDAT_T TM87={T11 2,T12 8,T13 7,T14 2,T15 2,T16 2,T21 14545,T22 8061,T23 2937,T24 3730,T25 3625,T26 3612,K1
299,K2 301,K3 299,K4 309,K5 300,K6 301,O1 20,O2 30,ID 87,OVM 100,TFM 1.00000}
DECL E6POS XP219={X -828.427551,Y -426.434845,Z 516.661,A -34.0046768,B 82.7133560,C 153.384689,S 2,T 10,E1 0.0,E2 0.0,E3
0.0,E4 0.0,E5 0.0,E6 0.0}
DECL FDAT FP219={TOOL_NO 10,BASE_NO 14,IPO_FRAME #BASE,POINT2[] " ",TQ_STATE TRUE}
DECL LDAT LCPDAT218={VEL 2.00000,ACC 100.000,APO_DIST 100.000,APO_FAC 50.0000,AXIS_VEL 100.000,AXIS_ACC
100.000,ORI_TYP #JOINT,CIRC_TYP #BASE,JERK_FAC 50.0000,GEAR_JERK 50.0000,EXAX_IGN 0}
DECL TQM_TQDAT_T TM88={T11 4,T12 9,T13 8,T14 19,T15 3,T16 9,T21 28194,T22 16494,T23 5479,T24 51701,T25 4360,T26
34631,K1 299,K2 301,K3 299,K4 309,K5 300,K6 301,O1 20,O2 30,ID 88,OVM 100,TFM 1.00000}
DECL E6POS XP220={X -887.439392,Y -562.937500,Z 520.018188,A -32.8640747,B 80.0340652,C 179.112579,S 2,T 10,E1 0.0,E2 0.0,E3
0.0,E4 0.0,E5 0.0,E6 0.0}
DECL FDAT FP220={TOOL_NO 10,BASE_NO 14,IPO_FRAME #BASE,POINT2[] " ",TQ_STATE TRUE}
DECL LDAT LCPDAT219={VEL 2.00000,ACC 100.000,APO_DIST 100.000,APO_FAC 50.0000,AXIS_VEL 100.000,AXIS_ACC
100.000,ORI_TYP #JOINT,CIRC_TYP #BASE,JERK_FAC 50.0000,GEAR_JERK 50.0000,EXAX_IGN 0}
DECL TQM_TQDAT_T TM89={T11 3,T12 11,T13 10,T14 12,T15 12,T16 5,T21 15517,T22 50091,T23 24240,T24 16228,T25 10288,T26
5374,K1 299,K2 301,K3 299,K4 309,K5 300,K6 301,O1 20,O2 30,ID 89,OVM 100,TFM 1.00000}
DECL E6POS XP221={X -863.809,Y -617.818481,Z 528.673035,A -32.8623886,B 80.0287704,C 179.113556,S 2,T 10,E1 0.0,E2 0.0,E3
0.0,E4 0.0,E5 0.0,E6 0.0}
DECL FDAT FP221={TOOL_NO 10,BASE_NO 14,IPO_FRAME #BASE,POINT2[] " ",TQ_STATE TRUE}
DECL LDAT LCPDAT220={VEL 2.00000,ACC 100.000,APO_DIST 100.000,APO_FAC 50.0000,AXIS_VEL 100.000,AXIS_ACC
100.000,ORI_TYP #JOINT,CIRC_TYP #BASE,JERK_FAC 50.0000,GEAR_JERK 50.0000,EXAX_IGN 0}
DECL TQM_TQDAT_T TM90={T11 2,T12 7,T13 8,T14 10,T15 11,T16 4,T21 21360,T22 14558,T23 5815,T24 11183,T25 12927,T26
6846,K1 299,K2 301,K3 299,K4 309,K5 300,K6 301,O1 20,O2 30,ID 90,OVM 100,TFM 1.00000}
DECL E6POS XP222={X -876.347656,Y -644.445129,Z 529.357666,A -35.3162727,B 80.2306442,C 176.695267,S 2,T 10,E1 0.0,E2 0.0,E3
0.0,E4 0.0,E5 0.0,E6 0.0}
DECL FDAT FP222={TOOL_NO 10,BASE_NO 14,IPO_FRAME #BASE,POINT2[] " ",TQ_STATE TRUE}
DECL LDAT LCPDAT221={VEL 2.00000,ACC 100.000,APO_DIST 100.000,APO_FAC 50.0000,AXIS_VEL 100.000,AXIS_ACC
100.000,ORI_TYP #JOINT,CIRC_TYP #BASE,JERK_FAC 50.0000,GEAR_JERK 50.0000,EXAX_IGN 0}
DECL TQM_TQDAT_T TM91={T11 2,T12 2,T13 9,T14 2,T15 6,T16 4,T21 7726,T22 1595,T23 4697,T24 16342,T25 2940,T26 25809,K1
299,K2 301,K3 299,K4 309,K5 300,K6 301,O1 20,O2 30,ID 91,OVM 100,TFM 1.00000}
DECL E6POS XP223={X -884.916443,Y -639.267,Z 527.634583,A -35.3153419,B 80.2296143,C 175.882660,S 2,T 10,E1 0.0,E2 0.0,E3
0.0,E4 0.0,E5 0.0,E6 0.0}
DECL FDAT FP223={TOOL_NO 10,BASE_NO 14,IPO_FRAME #BASE,POINT2[] " ",TQ_STATE TRUE}
DECL LDAT LCPDAT222={VEL 2.00000,ACC 100.000,APO_DIST 100.000,APO_FAC 50.0000,AXIS_VEL 100.000,AXIS_ACC
100.000,ORI_TYP #JOINT,CIRC_TYP #BASE,JERK_FAC 50.0000,GEAR_JERK 50.0000,EXAX_IGN 0}
DECL TQM_TQDAT_T TM92={T11 0,T12 1,T13 8,T14 3,T15 5,T16 1,T21 20540,T22 11134,T23 5804,T24 8518,T25 1576,T26 5380,K1
299,K2 301,K3 299,K4 309,K5 300,K6 301,O1 20,O2 30,ID 92,OVM 100,TFM 1.00000}
DECL E6POS XP224={X -890.453796,Y -636.014343,Z 526.524597,A -35.3132095,B 80.2273560,C 175.163040,S 2,T 10,E1 0.0,E2 0.0,E3
0.0,E4 0.0,E5 0.0,E6 0.0}
DECL FDAT FP224={TOOL_NO 10,BASE_NO 14,IPO_FRAME #BASE,POINT2[] " ",TQ_STATE TRUE}
DECL LDAT LCPDAT223={VEL 2.00000,ACC 100.000,APO_DIST 100.000,APO_FAC 50.0000,AXIS_VEL 100.000,AXIS_ACC
100.000,ORI_TYP #JOINT,CIRC_TYP #BASE,JERK_FAC 50.0000,GEAR_JERK 50.0000,EXAX_IGN 0}
DECL TQM_TQDAT_T TM93={T11 1,T12 1,T13 9,T14 5,T15 5,T16 2,T21 20540,T22 25210,T23 8300,T24 13638,T25 5293,T26 5380,K1
299,K2 301,K3 299,K4 309,K5 300,K6 301,O1 20,O2 30,ID 93,OVM 100,TFM 1.00000}
DECL E6POS XP225={X -896.343201,Y -632.702393,Z 525.371155,A -35.4552727,B 80.4566574,C 173.976959,S 2,T 10,E1 0.0,E2 0.0,E3
0.0,E4 0.0,E5 0.0,E6 0.0}
DECL FDAT FP225={TOOL_NO 10,BASE_NO 14,IPO_FRAME #BASE,POINT2[] " ",TQ_STATE TRUE}
DECL LDAT LCPDAT224={VEL 2.00000,ACC 100.000,APO_DIST 100.000,APO_FAC 50.0000,AXIS_VEL 100.000,AXIS_ACC
100.000,ORI_TYP #JOINT,CIRC_TYP #BASE,JERK_FAC 50.0000,GEAR_JERK 50.0000,EXAX_IGN 0}
DECL TQM_TQDAT_T TM94={T11 1,T12 1,T13 9,T14 5,T15 5,T16 2,T21 8331,T22 17838,T23 6640,T24 11990,T25 3387,T26 4736,K1
299,K2 301,K3 299,K4 309,K5 300,K6 301,O1 20,O2 30,ID 94,OVM 100,TFM 1.00000}
DECL E6POS XP226={X -891.352234,Y -611.314636,Z 523.939880,A -35.4475822,B 80.4489136,C 170.499542,S 2,T 10,E1 0.0,E2 0.0,E3
0.0,E4 0.0,E5 0.0,E6 0.0}
DECL FDAT FP226={TOOL_NO 10,BASE_NO 14,IPO_FRAME #BASE,POINT2[] " ",TQ_STATE TRUE}
DECL LDAT LCPDAT225={VEL 2.00000,ACC 100.000,APO_DIST 100.000,APO_FAC 50.0000,AXIS_VEL 100.000,AXIS_ACC
100.000,ORI_TYP #JOINT,CIRC_TYP #BASE,JERK_FAC 50.0000,GEAR_JERK 50.0000,EXAX_IGN 0}
DECL TQM_TQDAT_T TM95={T11 200,T12 200,T13 200,T14 200,T15 200,T16 200,T21 1000,T22 1000,T23 1000,T24 1000,T25
1000,T26 1000,K1 306,K2 308,K3 303,K4 304,K5 303,K6 306,O1 20,O2 30,ID 95,OVM 0,TFM 1.00000}
DECL E6POS XP227={X -897.109863,Y -632.296,Z 525.212585,A -35.2723846,B 80.2261047,C 172.538834,S 2,T 10,E1 0.0,E2 0.0,E3
0.0,E4 0.0,E5 0.0,E6 0.0}
DECL FDAT FP227={TOOL_NO 10,BASE_NO 14,IPO_FRAME #BASE,POINT2[] " ",TQ_STATE TRUE}
DECL LDAT LCPDAT226={VEL 2.00000,ACC 100.000,APO_DIST 100.000,APO_FAC 50.0000,AXIS_VEL 100.000,AXIS_ACC
100.000,ORI_TYP #JOINT,CIRC_TYP #BASE,JERK_FAC 50.0000,GEAR_JERK 50.0000,EXAX_IGN 0}

```

```

DECL TQM_TQDAT_T TM96={T11 1,T12 5,T13 7,T14 6,T15 6,T16 2,T21 9413,T22 27469,T23 7653,T24 6942,T25 5492,T26 4323,K1
299,K2 301,K3 299,K4 309,K5 300,K6 301,O1 20,O2 30,ID 96,OVM 100,TMF 1.00000}
DECL E6POS XP228={X -892.198730,Y -615.654785,Z 524.222,A -35.2662621,B 80.2197113,C 169.586426,S 2,T 10,E1 0.0,E2 0.0,E3
0.0,E4 0.0,E5 0.0,E6 0.0}
DECL FDAT FP228={TOOL_NO 10,BASE_NO 14,IPO_FRAME #BASE,POINT2[] " ",TQ_STATE TRUE}
DECL LDAT LCPDAT227={VEL 2.00000,ACC 100.000,APO_DIST 100.000,APO_FAC 50.0000,AXIS_VEL 100.000,AXIS_ACC
100.000,ORI_TYP #JOINT,CIRC_TYP #BASE,JERK_FAC 50.0000,GEAR_JERK 50.0000,EXAX_IGN 0}
DECL TQM_TQDAT_T TM97={T11 1,T12 5,T13 10,T14 9,T15 13,T16 3,T21 14142,T22 9590,T23 13953,T24 12630,T25 10701,T26
5601,K1 299,K2 301,K3 299,K4 309,K5 300,K6 300,O1 20,O2 30,ID 97,OVM 100,TMF 1.00000}
DECL E6POS XP229={X -886.991699,Y -599.173889,Z 523.285400,A -35.0576172,B 80.0615540,C 167.121063,S 2,T 10,E1 0.0,E2 0.0,E3
0.0,E4 0.0,E5 0.0,E6 0.0}
DECL FDAT FP229={TOOL_NO 10,BASE_NO 14,IPO_FRAME #BASE,POINT2[] " ",TQ_STATE TRUE}
DECL LDAT LCPDAT228={VEL 2.00000,ACC 100.000,APO_DIST 100.000,APO_FAC 50.0000,AXIS_VEL 100.000,AXIS_ACC
100.000,ORI_TYP #JOINT,CIRC_TYP #BASE,JERK_FAC 50.0000,GEAR_JERK 50.0000,EXAX_IGN 0}
DECL TQM_TQDAT_T TM98={T11 1,T12 1,T13 7,T14 10,T15 8,T16 2,T21 15662,T22 6767,T23 5142,T24 16579,T25 5096,T26 4675,K1
299,K2 301,K3 299,K4 309,K5 300,K6 300,O1 20,O2 30,ID 98,OVM 100,TMF 1.00000}
DECL E6POS XP230={X -881.821289,Y -583.670776,Z 522.456726,A -34.7420502,B 79.8601074,C 164.795197,S 2,T 10,E1 0.0,E2 0.0,E3
0.0,E4 0.0,E5 0.0,E6 0.0}
DECL FDAT FP230={TOOL_NO 10,BASE_NO 14,IPO_FRAME #BASE,POINT2[] " ",TQ_STATE TRUE}
DECL LDAT LCPDAT229={VEL 2.00000,ACC 100.000,APO_DIST 100.000,APO_FAC 50.0000,AXIS_VEL 100.000,AXIS_ACC
100.000,ORI_TYP #JOINT,CIRC_TYP #BASE,JERK_FAC 50.0000,GEAR_JERK 50.0000,EXAX_IGN 0}
DECL TQM_TQDAT_T TM99={T11 1,T12 9,T13 6,T14 6,T15 6,T16 2,T21 9641,T22 31631,T23 11038,T24 9822,T25 1905,T26 3197,K1
299,K2 301,K3 299,K4 309,K5 300,K6 300,O1 20,O2 30,ID 99,OVM 100,TMF 1.00000}
DECL E6POS XP231={X -874.969177,Y -586.045776,Z 523.708,A -34.3919334,B 79.6416473,C 164.290482,S 2,T 10,E1 0.0,E2 0.0,E3
0.0,E4 0.0,E5 0.0,E6 0.0}
DECL FDAT FP231={TOOL_NO 10,BASE_NO 14,IPO_FRAME #BASE,POINT2[] " ",TQ_STATE TRUE}
DECL LDAT LCPDAT230={VEL 2.00000,ACC 100.000,APO_DIST 100.000,APO_FAC 50.0000,AXIS_VEL 100.000,AXIS_ACC
100.000,ORI_TYP #JOINT,CIRC_TYP #BASE,JERK_FAC 50.0000,GEAR_JERK 50.0000,EXAX_IGN 0}
DECL TQM_TQDAT_T TM100={T11 1,T12 10,T13 7,T14 7,T15 6,T16 3,T21 9879,T22 31631,T23 11038,T24 14280,T25 4844,T26
4254,K1 299,K2 301,K3 299,K4 309,K5 300,K6 300,O1 20,O2 30,ID 100,OVM 100,TMF 1.00000}
DECL E6POS XP232={X -856.124878,Y -592.172,Z 527.239,A -33.5699615,B 79.1141586,C 164.146011,S 2,T 10,E1 0.0,E2 0.0,E3 0.0,E4
0.0,E5 0.0,E6 0.0}
DECL FDAT FP232={TOOL_NO 10,BASE_NO 14,IPO_FRAME #BASE,POINT2[] " ",TQ_STATE TRUE}
DECL LDAT LCPDAT231={VEL 2.00000,ACC 100.000,APO_DIST 100.000,APO_FAC 50.0000,AXIS_VEL 100.000,AXIS_ACC
100.000,ORI_TYP #JOINT,CIRC_TYP #BASE,JERK_FAC 50.0000,GEAR_JERK 50.0000,EXAX_IGN 0}
DECL TQM_TQDAT_T TM101={T11 1,T12 9,T13 8,T14 9,T15 6,T16 2,T21 8930,T22 13421,T23 6655,T24 13769,T25 5063,T26 4546,K1
299,K2 301,K3 299,K4 309,K5 300,K6 300,O1 20,O2 30,ID 101,OVM 100,TMF 1.00000}
DECL E6POS XP233={X -786.634827,Y -611.655518,Z 540.386780,A -33.5653534,B 79.1117783,C 156.404526,S 2,T 10,E1 0.0,E2 0.0,E3
0.0,E4 0.0,E5 0.0,E6 0.0}
DECL FDAT FP233={TOOL_NO 10,BASE_NO 14,IPO_FRAME #BASE,POINT2[] " ",TQ_STATE TRUE}
DECL LDAT LCPDAT232={VEL 2.00000,ACC 100.000,APO_DIST 100.000,APO_FAC 50.0000,AXIS_VEL 100.000,AXIS_ACC
100.000,ORI_TYP #JOINT,CIRC_TYP #BASE,JERK_FAC 50.0000,GEAR_JERK 50.0000,EXAX_IGN 0}
DECL TQM_TQDAT_T TM102={T11 1,T12 8,T13 11,T14 10,T15 3,T16 4,T21 12578,T22 32172,T23 22876,T24 15430,T25 11385,T26
5991,K1 299,K2 301,K3 299,K4 309,K5 300,K6 300,O1 20,O2 30,ID 102,OVM 100,TMF 1.00000}
DECL E6POS XP234={X -927.964417,Y -236.401886,Z 490.862640,A -11.1641273,B 75.3253708,C 137.929977,S 2,T 10,E1 0.0,E2 0.0,E3
0.0,E4 0.0,E5 0.0,E6 0.0}
DECL FDAT FP234={TOOL_NO 10,BASE_NO 14,IPO_FRAME #BASE,POINT2[] " ",TQ_STATE TRUE}
DECL LDAT LCPDAT233={VEL 2.00000,ACC 100.000,APO_DIST 100.000,APO_FAC 50.0000,AXIS_VEL 100.000,AXIS_ACC
100.000,ORI_TYP #JOINT,CIRC_TYP #BASE,JERK_FAC 50.0000,GEAR_JERK 50.0000,EXAX_IGN 0}
DECL TQM_TQDAT_T TM103={T11 4,T12 7,T13 7,T14 10,T15 3,T16 7,T21 18859,T22 37535,T23 18286,T24 15807,T25 11024,T26
7815,K1 299,K2 301,K3 299,K4 309,K5 300,K6 300,O1 20,O2 30,ID 103,OVM 100,TMF 1.00000}
DECL E6POS XP235={X -959.201050,Y -225.549393,Z 513.609131,A -11.1640978,B 75.3253632,C 139.417816,S 2,T 10,E1 0.0,E2 0.0,E3
0.0,E4 0.0,E5 0.0,E6 0.0}
DECL FDAT FP235={TOOL_NO 10,BASE_NO 14,IPO_FRAME #BASE,POINT2[] " ",TQ_STATE TRUE}
DECL LDAT LCPDAT234={VEL 2.00000,ACC 100.000,APO_DIST 100.000,APO_FAC 50.0000,AXIS_VEL 100.000,AXIS_ACC
100.000,ORI_TYP #JOINT,CIRC_TYP #BASE,JERK_FAC 50.0000,GEAR_JERK 50.0000,EXAX_IGN 0}
DECL TQM_TQDAT_T TM104={T11 0,T12 11,T13 5,T14 13,T15 1,T16 3,T21 6616,T22 83129,T23 8969,T24 19071,T25 1918,T26
4962,K1 299,K2 301,K3 299,K4 309,K5 300,K6 300,O1 20,O2 30,ID 104,OVM 100,TMF 1.00000}
DECL E6POS XP236={X -961.318054,Y -226.740540,Z 513.125610,A -11.8614092,B 75.5349350,C 139.733078,S 2,T 10,E1 0.0,E2 0.0,E3
0.0,E4 0.0,E5 0.0,E6 0.0}
DECL FDAT FP236={TOOL_NO 10,BASE_NO 14,IPO_FRAME #BASE,POINT2[] " ",TQ_STATE TRUE}
DECL LDAT LCPDAT235={VEL 2.00000,ACC 100.000,APO_DIST 100.000,APO_FAC 50.0000,AXIS_VEL 100.000,AXIS_ACC
100.000,ORI_TYP #JOINT,CIRC_TYP #BASE,JERK_FAC 50.0000,GEAR_JERK 50.0000,EXAX_IGN 0}
DECL TQM_TQDAT_T TM105={T11 0,T12 13,T13 5,T14 13,T15 3,T16 9,T21 7954,T22 83129,T23 31305,T24 36595,T25 3102,T26
35969,K1 299,K2 301,K3 299,K4 309,K5 300,K6 300,O1 20,O2 30,ID 105,OVM 100,TMF 1.00000}
DECL E6POS XP237={X -962.823059,Y -227.543442,Z 512.799438,A -12.7889528,B 75.8106613,C 140.007828,S 2,T 10,E1 0.0,E2 0.0,E3
0.0,E4 0.0,E5 0.0,E6 0.0}
DECL FDAT FP237={TOOL_NO 10,BASE_NO 14,IPO_FRAME #BASE,POINT2[] " ",TQ_STATE TRUE}
DECL LDAT LCPDAT236={VEL 2.00000,ACC 100.000,APO_DIST 100.000,APO_FAC 50.0000,AXIS_VEL 100.000,AXIS_ACC
100.000,ORI_TYP #JOINT,CIRC_TYP #BASE,JERK_FAC 50.0000,GEAR_JERK 50.0000,EXAX_IGN 0}
DECL TQM_TQDAT_T TM106={T11 0,T12 15,T13 6,T14 13,T15 5,T16 9,T21 8221,T22 83129,T23 31305,T24 36595,T25 10537,T26
35969,K1 299,K2 301,K3 299,K4 309,K5 300,K6 300,O1 20,O2 30,ID 106,OVM 100,TMF 1.00000}
DECL E6POS XP238={X -954.408630,Y -246.652145,Z 515.943542,A -12.7889500,B 75.8106613,C 143.140976,S 2,T 10,E1 0.0,E2 0.0,E3
0.0,E4 0.0,E5 0.0,E6 0.0}
DECL FDAT FP238={TOOL_NO 10,BASE_NO 14,IPO_FRAME #BASE,POINT2[] " ",TQ_STATE TRUE}

```

```

DECL LDAT LCPDAT237={VEL 2.00000,ACC 100.000,APO_DIST 100.000,APO_FAC 50.0000,AXIS_VEL 100.000,AXIS_ACC
100.000,ORI_TYP #JOINT,CIRC_TYP #BASE,JERK_FAC 50.0000,GEAR_JERK 50.0000,EXAX_IGN 0}
DECL TQM_TQDAT_T TM107={T11 1,T12 12,T13 9,T14 9,T15 4,T16 9,T21 13278,T22 23664,T23 14432,T24 44704,T25 12924,T26
32078,K1 299,K2 301,K3 299,K4 309,K5 300,K6 301,O1 20,O2 30,ID 107,OVM 100,TMF 1.00000}
DECL E6POS XP239={X -944.871887,Y -260.718872,Z 535.073181,A -9.28047,B 74.3758850,C 149.515945,S 2,T 10,E1 0.0,E2 0.0,E3
0.0,E4 0.0,E5 0.0,E6 0.0}
DECL FDAT FP239={TOOL_NO 10,BASE_NO 14,IPO_FRAME #BASE,POINT2[] " ",TQ_STATE TRUE}
DECL LDAT LCPDAT238={VEL 2.00000,ACC 100.000,APO_DIST 100.000,APO_FAC 50.0000,AXIS_VEL 100.000,AXIS_ACC
100.000,ORI_TYP #JOINT,CIRC_TYP #BASE,JERK_FAC 50.0000,GEAR_JERK 50.0000,EXAX_IGN 0}
DECL TQM_TQDAT_T TM108={T11 1,T12 9,T13 4,T14 5,T15 2,T16 0,T21 6464,T22 17042,T23 7287,T24 9132,T25 10125,T26 3938,K1
299,K2 301,K3 299,K4 309,K5 300,K6 301,O1 20,O2 30,ID 108,OVM 100,TMF 1.00000}
DECL E6POS XP240={X -941.045593,Y -259.047882,Z 536.111084,A -10.2730312,B 74.8318329,C 149.494843,S 2,T 10,E1 0.0,E2 0.0,E3
0.0,E4 0.0,E5 0.0,E6 0.0}
DECL FDAT FP240={TOOL_NO 10,BASE_NO 14,IPO_FRAME #BASE,POINT2[] " ",TQ_STATE TRUE}
DECL LDAT LCPDAT239={VEL 2.00000,ACC 100.000,APO_DIST 100.000,APO_FAC 50.0000,AXIS_VEL 100.000,AXIS_ACC
100.000,ORI_TYP #JOINT,CIRC_TYP #BASE,JERK_FAC 50.0000,GEAR_JERK 50.0000,EXAX_IGN 0}
DECL TQM_TQDAT_T TM109={T11 2,T12 13,T13 5,T14 19,T15 2,T16 10,T21 14370,T22 27301,T23 7287,T24 50214,T25 10125,T26
32509,K1 299,K2 301,K3 299,K4 309,K5 300,K6 301,O1 20,O2 30,ID 109,OVM 100,TMF 1.00000}
DECL E6POS XP241={X -929.275757,Y -284.902588,Z 540.494324,A -10.2729301,B 74.8317795,C 153.314987,S 2,T 10,E1 0.0,E2 0.0,E3
0.0,E4 0.0,E5 0.0,E6 0.0}
DECL FDAT FP241={TOOL_NO 10,BASE_NO 14,IPO_FRAME #BASE,POINT2[] " ",TQ_STATE TRUE}
DECL LDAT LCPDAT240={VEL 2.00000,ACC 100.000,APO_DIST 100.000,APO_FAC 50.0000,AXIS_VEL 100.000,AXIS_ACC
100.000,ORI_TYP #JOINT,CIRC_TYP #BASE,JERK_FAC 50.0000,GEAR_JERK 50.0000,EXAX_IGN 0}
DECL TQM_TQDAT_T TM110={T11 2,T12 13,T13 8,T14 8,T15 3,T16 3,T21 17321,T22 21039,T23 7495,T24 4217,T25 12404,T26
6681,K1 299,K2 301,K3 299,K4 309,K5 300,K6 301,O1 20,O2 30,ID 110,OVM 100,TMF 1.00000}
DECL E6POS XP242={X -910.650574,Y -319.681488,Z 547.139343,A -10.2728701,B 74.8317337,C 158.313156,S 2,T 10,E1 0.0,E2 0.0,E3
0.0,E4 0.0,E5 0.0,E6 0.0}
DECL FDAT FP242={TOOL_NO 10,BASE_NO 14,IPO_FRAME #BASE,POINT2[] " ",TQ_STATE TRUE}
DECL LDAT LCPDAT241={VEL 2.00000,ACC 100.000,APO_DIST 100.000,APO_FAC 50.0000,AXIS_VEL 100.000,AXIS_ACC
100.000,ORI_TYP #JOINT,CIRC_TYP #BASE,JERK_FAC 50.0000,GEAR_JERK 50.0000,EXAX_IGN 0}
DECL TQM_TQDAT_T TM111={T11 0,T12 9,T13 7,T14 4,T15 2,T16 2,T21 12298,T22 13890,T23 4234,T24 2266,T25 1608,T26 2623,K1
299,K2 301,K3 299,K4 309,K5 300,K6 301,O1 20,O2 30,ID 111,OVM 100,TMF 1.00000}
DECL E6POS XP243={X -899.755432,Y -342.802765,Z 551.163452,A -10.5039625,B 75.0123215,C 161.679794,S 2,T 10,E1 0.0,E2 0.0,E3
0.0,E4 0.0,E5 0.0,E6 0.0}
DECL FDAT FP243={TOOL_NO 10,BASE_NO 14,IPO_FRAME #BASE,POINT2[] " ",TQ_STATE TRUE}
DECL LDAT LCPDAT242={VEL 2.00000,ACC 100.000,APO_DIST 100.000,APO_FAC 50.0000,AXIS_VEL 100.000,AXIS_ACC
100.000,ORI_TYP #JOINT,CIRC_TYP #BASE,JERK_FAC 50.0000,GEAR_JERK 50.0000,EXAX_IGN 0}
DECL TQM_TQDAT_T TM112={T11 0,T12 0,T13 0,T14 0,T15 0,T16 0,T21 0,T22 0,T23 0,T24 0,T25 0,T26 0,K1 299,K2 301,K3 299,K4
309,K5 300,K6 301,O1 20,O2 30,ID 112,OVM 100,TMF 1.00000}
DECL E6POS XP244={X -890.618713,Y -365.440674,Z 554.673157,A -10.5039625,B 75.0123215,C 165.144577,S 2,T 10,E1 0.0,E2 0.0,E3
0.0,E4 0.0,E5 0.0,E6 0.0}
DECL FDAT FP244={TOOL_NO 10,BASE_NO 14,IPO_FRAME #BASE,POINT2[] " ",TQ_STATE TRUE}
DECL LDAT LCPDAT243={VEL 2.00000,ACC 100.000,APO_DIST 100.000,APO_FAC 50.0000,AXIS_VEL 100.000,AXIS_ACC
100.000,ORI_TYP #JOINT,CIRC_TYP #BASE,JERK_FAC 50.0000,GEAR_JERK 50.0000,EXAX_IGN 0}
DECL TQM_TQDAT_T TM113={T11 1,T12 10,T13 8,T14 7,T15 3,T16 7,T21 12946,T22 8928,T23 5163,T24 11842,T25 8160,T26
14809,K1 299,K2 301,K3 299,K4 309,K5 300,K6 301,O1 20,O2 30,ID 113,OVM 100,TMF 1.00000}
DECL E6POS XP245={X -875.009,Y -411.972229,Z 561.051331,A -10.5039673,B 75.0123215,C 171.521469,S 2,T 10,E1 0.0,E2 0.0,E3
0.0,E4 0.0,E5 0.0,E6 0.0}
DECL FDAT FP245={TOOL_NO 10,BASE_NO 14,IPO_FRAME #BASE,POINT2[] " ",TQ_STATE TRUE}
DECL LDAT LCPDAT244={VEL 2.00000,ACC 100.000,APO_DIST 100.000,APO_FAC 50.0000,AXIS_VEL 100.000,AXIS_ACC
100.000,ORI_TYP #JOINT,CIRC_TYP #BASE,JERK_FAC 50.0000,GEAR_JERK 50.0000,EXAX_IGN 0}
DECL TQM_TQDAT_T TM114={T11 1,T12 10,T13 8,T14 6,T15 3,T16 4,T21 18014,T22 21344,T23 6219,T24 14265,T25 8105,T26
5751,K1 299,K2 301,K3 299,K4 309,K5 300,K6 301,O1 20,O2 30,ID 114,OVM 100,TMF 1.00000}
DECL E6POS XP246={X -863.639160,Y -465.940704,Z 566.676514,A -10.5039711,B 75.0123444,C 178.801819,S 2,T 10,E1 0.0,E2 0.0,E3
0.0,E4 0.0,E5 0.0,E6 0.0}
DECL FDAT FP246={TOOL_NO 10,BASE_NO 14,IPO_FRAME #BASE,POINT2[] " ",TQ_STATE TRUE}
DECL LDAT LCPDAT245={VEL 2.00000,ACC 100.000,APO_DIST 100.000,APO_FAC 50.0000,AXIS_VEL 100.000,AXIS_ACC
100.000,ORI_TYP #JOINT,CIRC_TYP #BASE,JERK_FAC 50.0000,GEAR_JERK 50.0000,EXAX_IGN 0}
DECL TQM_TQDAT_T TM115={T11 3,T12 9,T13 8,T14 1,T15 1,T16 1,T21 6015,T22 6417,T23 6139,T24 6492,T25 10338,T26 3468,K1
299,K2 301,K3 299,K4 309,K5 300,K6 301,O1 20,O2 30,ID 115,OVM 100,TMF 1.00000}
DECL E6POS XP247={X -854.971680,Y -467.368774,Z 569.027771,A -10.4870749,B 74.4692917,C 179.591400,S 2,T 10,E1 0.0,E2 0.0,E3
0.0,E4 0.0,E5 0.0,E6 0.0}
DECL FDAT FP247={TOOL_NO 10,BASE_NO 14,IPO_FRAME #BASE,POINT2[] " ",TQ_STATE TRUE}
DECL LDAT LCPDAT246={VEL 2.00000,ACC 100.000,APO_DIST 100.000,APO_FAC 50.0000,AXIS_VEL 100.000,AXIS_ACC
100.000,ORI_TYP #JOINT,CIRC_TYP #BASE,JERK_FAC 50.0000,GEAR_JERK 50.0000,EXAX_IGN 0}
DECL TQM_TQDAT_T TM116={T11 3,T12 9,T13 10,T14 5,T15 4,T16 1,T21 23382,T22 6417,T23 18053,T24 10000,T25 10338,T26
4944,K1 299,K2 301,K3 299,K4 309,K5 300,K6 301,O1 20,O2 30,ID 116,OVM 100,TMF 1.00000}
DECL E6POS XP248={X -835.625854,Y -472.166077,Z 631.071960,A -12.1836395,B 64.0369415,C -175.606094,S 2,T 10,E1 0.0,E2
0.0,E3 0.0,E4 0.0,E5 0.0,E6 0.0}
DECL FDAT FP248={TOOL_NO 10,BASE_NO 14,IPO_FRAME #BASE,POINT2[] " ",TQ_STATE TRUE}
DECL LDAT LCPDAT247={VEL 2.00000,ACC 100.000,APO_DIST 100.000,APO_FAC 50.0000,AXIS_VEL 100.000,AXIS_ACC
100.000,ORI_TYP #JOINT,CIRC_TYP #BASE,JERK_FAC 50.0000,GEAR_JERK 50.0000,EXAX_IGN 0}
DECL TQM_TQDAT_T TM117={T11 1,T12 11,T13 8,T14 13,T15 11,T16 3,T21 17322,T22 45375,T23 8845,T24 15069,T25 27866,T26
5762,K1 299,K2 301,K3 299,K4 309,K5 300,K6 301,O1 20,O2 30,ID 117,OVM 100,TMF 1.00000}

```

```

DECL E6POS XP249={X -871.905884,Y -509.018555,Z 631.093262,A -12.1846514,B 64.0384445,C -175.604050,S 2,T 10,E1 0.0,E2
0.0,E3 0.0,E4 0.0,E5 0.0,E6 0.0}
DECL FDAT FP249={TOOL_NO 10,BASE_NO 14,IPO_FRAME #BASE,POINT2[] " ",TQ_STATE TRUE}
DECL LDAT LCPDAT248={VEL 2.00000,ACC 100.000,APO_DIST 100.000,APO_FAC 50.0000,AXIS_VEL 100.000,AXIS_ACC
100.000,ORI_TYP #JOINT,CIRC_TYP #BASE,JERK_FAC 50.0000,GEAR_JERK 50.0000,EXAX_IGN 0}
DECL TQM_TQDAT_T TM118={T11 2,T12 1,T13 9,T14 3,T15 6,T16 1,T21 15256,T22 20996,T23 10569,T24 13410,T25 4998,T26
3692,K1 299,K2 301,K3 299,K4 309,K5 300,K6 301,O1 20,O2 30,ID 118,OVM 100,TMF 1.00000}
DECL E6POS XP250={X -888.835327,Y -525.598572,Z 646.381836,A -12.1846380,B 64.0384445,C -175.604065,S 2,T 10,E1 0.0,E2
0.0,E3 0.0,E4 0.0,E5 0.0,E6 0.0}
DECL FDAT FP250={TOOL_NO 10,BASE_NO 14,IPO_FRAME #BASE,POINT2[] " ",TQ_STATE TRUE}
DECL LDAT LCPDAT249={VEL 2.00000,ACC 100.000,APO_DIST 100.000,APO_FAC 50.0000,AXIS_VEL 100.000,AXIS_ACC
100.000,ORI_TYP #JOINT,CIRC_TYP #BASE,JERK_FAC 50.0000,GEAR_JERK 50.0000,EXAX_IGN 0}
DECL TQM_TQDAT_T TM119={T11 1,T12 1,T13 6,T14 12,T15 3,T16 10,T21 8806,T22 7597,T23 4818,T24 36531,T25 4522,T26
26685,K1 299,K2 301,K3 299,K4 309,K5 300,K6 301,O1 20,O2 30,ID 119,OVM 100,TMF 1.00000}
DECL E6POS XP251={X -893.137268,Y -524.388367,Z 644.253601,A -12.1451473,B 64.2937622,C -176.779572,S 2,T 10,E1 0.0,E2
0.0,E3 0.0,E4 0.0,E5 0.0,E6 0.0}
DECL FDAT FP251={TOOL_NO 10,BASE_NO 14,IPO_FRAME #BASE,POINT2[] " ",TQ_STATE TRUE}
DECL LDAT LCPDAT250={VEL 2.00000,ACC 100.000,APO_DIST 100.000,APO_FAC 50.0000,AXIS_VEL 100.000,AXIS_ACC
100.000,ORI_TYP #JOINT,CIRC_TYP #BASE,JERK_FAC 50.0000,GEAR_JERK 50.0000,EXAX_IGN 0}
DECL TQM_TQDAT_T TM120={T11 2,T12 0,T13 8,T14 2,T15 4,T16 4,T21 19482,T22 12782,T23 6366,T24 10080,T25 4481,T26
10295,K1 299,K2 301,K3 299,K4 309,K5 300,K6 301,O1 20,O2 30,ID 120,OVM 100,TMF 1.00000}
DECL E6POS XP252={X -896.584900,Y -523.495605,Z 642.562622,A -12.1435289,B 64.3091354,C -177.848679,S 2,T 10,E1 0.0,E2
0.0,E3 0.0,E4 0.0,E5 0.0,E6 0.0}
DECL FDAT FP252={TOOL_NO 10,BASE_NO 14,IPO_FRAME #BASE,POINT2[] " ",TQ_STATE TRUE}
DECL LDAT LCPDAT251={VEL 2.00000,ACC 100.000,APO_DIST 100.000,APO_FAC 50.0000,AXIS_VEL 100.000,AXIS_ACC
100.000,ORI_TYP #JOINT,CIRC_TYP #BASE,JERK_FAC 50.0000,GEAR_JERK 50.0000,EXAX_IGN 0}
DECL TQM_TQDAT_T TM121={T11 0,T12 0,T13 8,T14 0,T15 5,T16 3,T21 3174,T22 4135,T23 1776,T24 3831,T25 3222,T26 564,K1
299,K2 301,K3 299,K4 309,K5 300,K6 301,O1 20,O2 30,ID 121,OVM 100,TMF 1.00000}
DECL E6POS XP253={X -903.117859,Y -521.946228,Z 639.333374,A -12.1556787,B 64.0269241,C -179.960449,S 2,T 10,E1 0.0,E2
0.0,E3 0.0,E4 0.0,E5 0.0,E6 0.0}
DECL FDAT FP253={TOOL_NO 10,BASE_NO 14,IPO_FRAME #BASE,POINT2[] " ",TQ_STATE TRUE}
DECL LDAT LCPDAT252={VEL 2.00000,ACC 100.000,APO_DIST 100.000,APO_FAC 50.0000,AXIS_VEL 100.000,AXIS_ACC
100.000,ORI_TYP #JOINT,CIRC_TYP #BASE,JERK_FAC 50.0000,GEAR_JERK 50.0000,EXAX_IGN 0}
DECL TQM_TQDAT_T TM122={T11 0,T12 1,T13 8,T14 2,T15 5,T16 3,T21 9818,T22 11258,T23 4887,T24 8392,T25 6845,T26 3807,K1
299,K2 301,K3 299,K4 309,K5 300,K6 301,O1 20,O2 30,ID 122,OVM 100,TMF 1.00000}
DECL E6POS XP254={X -982.225525,Y -219.184418,Z 569.912354,A -12.1536121,B 63.8778343,C 139.377808,S 2,T 10,E1 0.0,E2 0.0,E3
0.0,E4 0.0,E5 0.0,E6 0.0}
DECL FDAT FP254={TOOL_NO 10,BASE_NO 14,IPO_FRAME #BASE,POINT2[] " ",TQ_STATE TRUE}
DECL LDAT LCPDAT253={VEL 2.00000,ACC 100.000,APO_DIST 100.000,APO_FAC 50.0000,AXIS_VEL 100.000,AXIS_ACC
100.000,ORI_TYP #JOINT,CIRC_TYP #BASE,JERK_FAC 50.0000,GEAR_JERK 50.0000,EXAX_IGN 0}
DECL TQM_TQDAT_T TM123={T11 200,T12 200,T13 200,T14 200,T15 200,T16 200,T21 1000,T22 1000,T23 1000,T24 1000,T25
1000,T26 1000,K1 306,K2 308,K3 303,K4 304,K5 303,K6 306,O1 20,O2 30,ID 123,OVM 0,TMF 1.00000}
DECL E6POS XP255={X -877.854431,Y -527.395813,Z 651.957153,A -12.1500940,B 64.0406494,C 139.288055,S 2,T 10,E1 0.0,E2 0.0,E3
0.0,E4 0.0,E5 0.0,E6 0.0}
DECL FDAT FP255={TOOL_NO 10,BASE_NO 14,IPO_FRAME #BASE,POINT2[] " ",TQ_STATE TRUE}
DECL LDAT LCPDAT254={VEL 2.00000,ACC 100.000,APO_DIST 100.000,APO_FAC 50.0000,AXIS_VEL 100.000,AXIS_ACC
100.000,ORI_TYP #JOINT,CIRC_TYP #BASE,JERK_FAC 50.0000,GEAR_JERK 50.0000,EXAX_IGN 0}
DECL TQM_TQDAT_T TM124={T11 2,T12 1,T13 7,T14 6,T15 11,T16 5,T21 16661,T22 11926,T23 24280,T24 14060,T25 10249,T26
9138,K1 299,K2 301,K3 299,K4 309,K5 300,K6 301,O1 20,O2 30,ID 124,OVM 100,TMF 1.00000}
ENDDAT

```