

UNIVERSIDAD SAN FRANCISCO DE QUITO USFQ

Colegio de Ciencias e Ingenierías

**On the Design of a RF Schottky Diode Rectifier for Energy
Harvesting Applications**
Artículo Académico

Joan Manuel Mendoza Domínguez

Ingeniería Eléctrica y Electrónica

Trabajo de titulación presentado como requisito
para la obtención del título de
Ingeniero Electrónico

Quito, 23 de marzo de 2018

UNIVERSIDAD SAN FRANCISCO DE QUITO USFQ
COLEGIO DE CIENCIAS E INGENIERÍAS

**HOJA DE CALIFICACIÓN
DE TRABAJO DE TITULACIÓN**

**On the Design of a RF Schottky Diode Rectifier for Energy Harvesting
Applications**

Joan Manuel Mendoza Domínguez

Calificación:

Nombre del profesor, Título académico

Alberto Sánchez , Ph.D.

Firma del profesor

Quito, 23 de marzo de 2018

Derechos de Autor

Por medio del presente documento certifico que he leído todas las Políticas y Manuales de la Universidad San Francisco de Quito USFQ, incluyendo la Política de Propiedad Intelectual USFQ, y estoy de acuerdo con su contenido, por lo que los derechos de propiedad intelectual del presente trabajo quedan sujetos a lo dispuesto en esas Políticas.

Asimismo, autorizo a la USFQ para que realice la digitalización y publicación de este trabajo en el repositorio virtual, de conformidad a lo dispuesto en el Art. 144 de la Ley Orgánica de Educación Superior.

Firma del estudiante:

Nombres y apellidos:

Joan Manuel Mendoza Domínguez

Código:

00110934

Cédula de Identidad:

1717578742

Lugar y fecha:

Quito, marzo de 2018

AGRADECIMIENTOS

Agradezco primeramente a Dios por permitirme llegar hasta este punto de mi vida y carrera profesional. A mis padres, por su apoyo incondicional para guiarme durante todo este proceso y saber aconsejarme de manera adecuada. A mi hermana, que siempre ha sido y será un modelo a seguir como persona y profesional. A mi abuelita, que siempre estuvo pendiente de mis estudios.

También agradezco a mis amigos de carrera con los que viví momentos de mayor esfuerzo y alegría.

Agradezco a todos mis profesores, sin su esfuerzo y conocimiento no hubiera podido culminar mi proyecto. De manera especial, agradezco a Alberto Sánchez por su apoyo y confianza para el desarrollo de este trabajo.

RESUMEN

Este documento informa sobre el uso del software Advanced Design System (ADS) para simular un rectificador de radiofrecuencia con el objetivo de obtener energía. Se utilizan mediciones de parámetros S de pequeña señal experimental a diferentes niveles de CC de un diodo Schottky para extraer los parámetros eléctricos reales y se emplea un método de optimización numérica para caracterizar el circuito equivalente de diodos de gran señal. El método consiste en cancelar los componentes parásitos del diodo y aislar tanto la capacitancia como la resistencia no lineales que se describen mediante las curvas de características I-V y C-V, respectivamente. En base a los resultados de la simulación, se fabrica y prueba un rectificador de 1900 MHz utilizando un diodo Skyworks Schottky HSMS-7630 con una eficiencia máxima del 25% a 0dBm.

Palabras clave: Cosecha de energía, diodo, circuito de grande señal, Parámetros S pequeña señal.

ABSTRACT

This paper reports on the use of Advanced Design System software (ADS) to simulate a radio frequency rectifier for energy harvesting purposes. Experimental small signal S-parameters measurements at different DC levels from a Schottky diode are used to extract the actual electrical parameters and a numerical optimization method is employed to characterize the large-signal diode equivalent circuit. The method consists of canceling the diode's parasitic components and isolate both non-linear capacitance and resistance which are described by the I-V and C-V characteristics curves respectively. Based on the simulation results, a 1900 MHz rectifier is fabricated and tested using a Skyworks Schottky diode HSMS-7630 with maximum efficiency of 25% at 0dBm.

Key words: Energy Harvesting, Diode, large-signal circuit, small S-parameter.

TABLA DE CONTENIDO

Introduction	8
Method for diode parameters extraction	9
RF Rectifier Design and Simulation.....	12
Results	13
Conclusion.....	13

On the Design of a RF Schottky Diode Rectifier for Energy Harvesting Applications

Joan Mendoza, *Student Member, IEEE*, and Alberto Sánchez, *Senior Member, IEEE*

Abstract—This paper reports on the use of Advanced Design System software (ADS) to simulate a radio frequency rectifier for energy harvesting purposes. Experimental small signal S-parameters measurements at different DC levels from a Schottky diode are used to extract the actual electrical parameters and a numerical optimization method is employed to characterize the large-signal diode equivalent circuit. The method consists of canceling the diode's parasitic components and isolate both non-linear capacitance and resistance which are described by the I-V and C-V characteristics curves respectively. Based on the simulation results, a 1900 MHz rectifier is fabricated and tested using a Skyworks Schottky diode HSMS-7630 with maximum efficiency of 25% at 0dBm.

I. INTRODUCTION

WITH the emergence of low power embedded systems special focus has been placed into energy efficiency and energy sufficiency. In particular radio frequency (RF) Energy Harvesting has the advantage that there is an extensive use of wireless devices, and therefore there is a substantial number of radio frequency sources. These new energy tendency allows to micro sensors, medical wireless implants and Radio Frequency Identification (RFID) to operate without any batteries [1]. Nowadays it is possible to find several reports and even commercial products on the use of RF Energy Harvesting at a diversity of frequency bands specially the ISM at 900 MHz and GSM band at 1800 MHz.

In order to obtain the maximum RF-DC conversion, it is necessary to comply with several restrictions and characteristics, among them a well-designed, efficient, low-loss rectifier circuit. Diodes are a fundamental part of rectifiers and one of the main sources of loss. A microwave voltage Schottky diode able to switch on under very low environment power is needed under some specific requirements such as: very low threshold voltage (V_{th}), low series resistance (R_s) and high saturation current [2]. Previous works have analyzed the performance of some diodes at low input power levels [3][4][5]

Active rectifier devices such as Schottky Diodes have a non-linear characteristic specially at such high frequencies. Since these circuits need to match their input impedance, through a matching circuit, with that of the antenna, it is necessary to determine its input impedance with precision. One simple method to do it is by simulation [5] using an appropriate diode model. Other methods directly measures the impedance [6] but it does not ensure good results, and it is time consuming. In

the first approach some characteristics of the diode are needed that can lead to systematic errors. Previous studies usually consider the diode SPICE parameters provided by the vendor based on a linear equivalent circuit, this is however is not true. Some works have been published not considering this assumption, for example in [4] the authors propose to eliminate this assumption by characterizing the diode by measuring its small signal S-parameter and using a graphical criteria. This method has been tested previously by [7] and the results are very accurate despite its simplicity.

There are other factors that affect the rectification conversion (RF-DC) efficiency. For specific RF bands harvesting, AC signals are composed by a fundamental tone and harmonics produced by a non linear device. Odd Harmonics are rejected by radial stubs after the rectification circuit [3]. Also, the rectifier topology itself determine higher or lower efficiency. The simplest rectifier topologies are the single serial connection and the single shunt connection. These are characterized to get high efficiency as low input power [3]

The work presented in this paper describes a method to extract diode parameters and model it in ADS - Advanced Design Software. Furthermore, it is evaluated by measuring the large signal characteristic of the actual diode. The paper is organized in the following way. Section II presents a description on the method to extract the scattering parameters of the diode and model it in ADS. Section III presents the design and simulation of the rectifier circuit. Section IV analyzes and compares the experimental and simulated results. Finally in section V conclusions are drawn.

II. DIODE PARAMETERS EXTRACTION

The procedure to determine diode parameters proposed in this paper is divided into two steps:

- 1) S-parameter measurement
- 2) Diode model parameter estimation

The following subsections present the details on these steps.

A. S-parameter Measurements

To measure the diode's scattering parameters any de-embedding technique can be applied as for example the method presented in [8]. In this work the Thru-Reflect-Line (TRL) calibration method was employed using a 1.6mm thick FR4 substrate with $\epsilon_r = 4.2$ and $\tan D = 0.015$. The TRL calibration isolates the diode S-parameters by characterizing the unwanted two port networks produced by cables, external connectors or soldering[9]. The TRL is composed by three fixtures. The first one, Thru, connects the VNA ports directly and its electrical length should be at least of the size of

J. Mendoza is with Universidad San Francisco de Quito USFQ, Colegio de Ciencias e Ingeniería, Campus Cumbayá, PO-Box 17-1200-841, Quito, Ecuador, (email:jmendoza@estud.usfq.edu.ec)

A. Sánchez is with Universidad San Francisco de Quito USFQ, Colegio de Ciencias e Ingeniería, Campus Cumbayá, PO-Box 17-1200-841, Quito, Ecuador, (email:asanchez@usfq.edu.ec)

TABLE I: TRL calibration kit physical dimensions

Fixture	width	Length
THRU	3.1 mm	42 mm
REFLECT	3.1 mm	21 mm
LINE	3.1 mm	58.7 mm

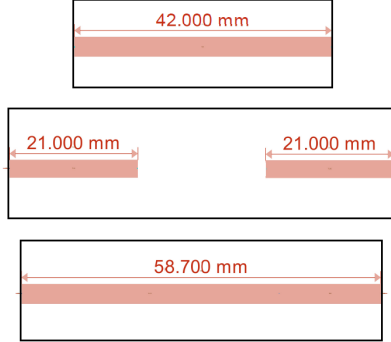

Fig. 1: TRL Calibration kit. The upper microstrip is the Thru fixture, the middle one is the Line, and the bottom fixture is the Reflect

one wave length (λ). The second fixture, Reflect, connects each port with an open or short circuit. And the last one, Line, creates a delay from the Thru fixture with an extra $\lambda/4$ electrical length. All the fixtures are designed with a 50Ω characteristic impedance. In the case of the Line fixture, its extra length is calculated using equation (1).

$$EL(cm) = \frac{15}{[f_1(GHz) + f_2(GHz)]} \quad (1)$$

where $f_1 = 1$ GHz and $f_2 = 4$ GHz with a frequency span of 4:1 are used to include the second harmonic. If span greater than 8:1 is needed, many Line fixtures must be used[9].

Using the previous expression an electrical length of 3 cm was obtained. The insertion phase difference produced by this length must be between 20° and 160° . Equation (2) is used to determine if the 3cm electrical length meets this condition[8].

$$\phi = 12(f)(EL) \quad (2)$$

where ϕ denotes the phase in degrees, f the frequency in GHz and EL the electrical length in cm. The calculated phases for each frequency are:

$$\begin{aligned} \phi_{1GHz} &= 36^\circ \\ \phi_{4GHz} &= 144^\circ \end{aligned}$$

which agree with the circuit requirements. The physical dimensions of the TRL calibration are tabulated in Table I and shown in Figure (2).

For S-parameter measurement, a test mount was designed in a microstrip with similar dimensions as the thru fixture. But, with a gap in the middle to test the diodes.

The calibration procedure can be done directly by an Agilent E5071B Network Analyzer (VNA) to characterize just the diode. If, this is no possible, the diode S-parameter can be isolated by any mathematical software solving the Signal Flow Graphs for each fixture [10]

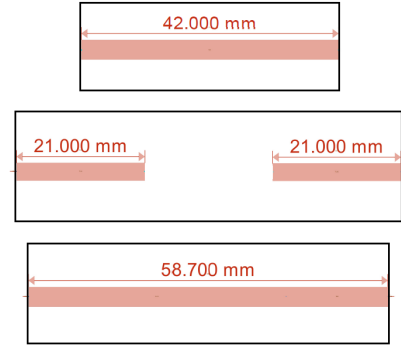

Fig. 2: TRL Calibration kit. The upper microstrip is the Thru fixture, the middle one is the Line, and the bottom fixture is the Reflect

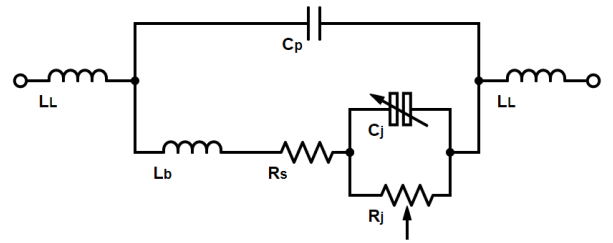

Fig. 3: Small-signal equivalent circuit

The measure setup for small signal is shown in (2). Two bias tees are used to polarize the diode at different DC voltages, and avoid any damage to the . Because of the frequency restriction determined by (2) in the TRL calibration, the measurements must keep the designed start and stop frequencies. In order to avoid wrong measurements, a voltmeter was added just before the mount test to ensure a precise bias voltage and compensate the voltage drop in the bias tee. Eight SMS-7630-79 Schottky diodes were measured at fifteen different DC bias voltages with a input power as low as -20dBm. For each DC value, a single touchtone, two port, file was generated by the VNA.

B. Diode Model Parameters Estimation

1) *Parasitic voltage independent parameters:* To extract the diode's large-signal equivalent circuit, a method that isolates non-linear components of the diode was employed. This method requires the large-signal equivalent circuit provided by the vendor, and a software simulator capable of handling negative lumped elements [5], such as ADS. The diode chosen to be modeled is a SMS7630-079 manufactured by Skyworks with 165mV threshold voltage and 2V breakdown voltage. Its large signal equivalent circuit is presented in Figure (2) [11].

In order to isolate C_j and R_j , as depicted in Figure (3b), a two port S-parameter block from ADS is needed. This function allows to import any touchtone file generated by the VNA. Furthermore, the negative lumped parasitic components should be placed in the schematic in a way such that it cancels their positive values[4]. The schematic is shown in figure (3a).

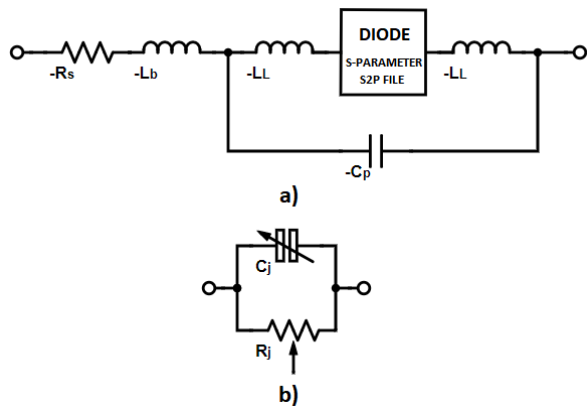

Fig. 4: a) Equivalent circuit with negative parasitic components b) Isolated Non-linear R_j and C_j

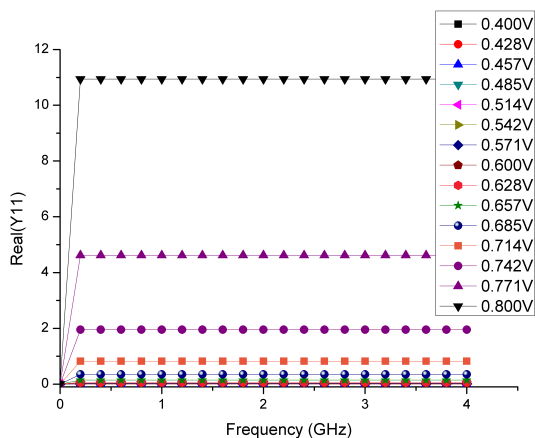

Fig. 5: Real Y-parameter characteristics for each bias voltage after eliminating the parasitic components

The equivalent admittance for the non-linear capacitance and resistance can be described by equation (3)

$$Y(\omega) = \frac{1}{R_j} + j\omega C_j \quad (3)$$

It is possible to use graphical criterion to verify if the effect of the parasitic components has been eliminated. The criterion requires that the real part of equation (3) is frequency independent and is represented by horizontal lines, whereas its imaginary part are straight lines passing through the origin[4]. This pattern is obtained by systematically canceling each of the components.

Figures (4) and (5) show the graphical criteria after all parasitic components have been canceled-out, whereas Table II presents the determined voltage independent components. As can be verified in [11], the value of these components approach to the vendors specifications.

2) *Non-linear voltage dependent parameters*: Once the voltage independent parameters have been determined it is possible to determine the non-linear capacitor and resistance. ADS has a powerful capability to create user-defined non-linear components which can be simulated as both conditions: large-signal and small-signal behavior (SSD) [5].

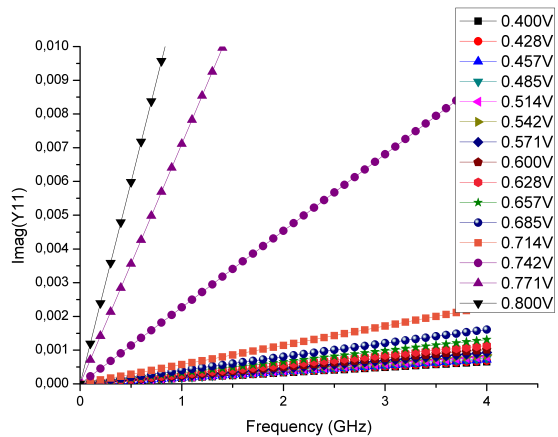

Fig. 6: Imaginary Y-parameter characteristics for each bias voltage after eliminating the parasitic components

TABLE II: Parasitic components

Parameter	value
R_s	6.6Ω
L_b	$0.26nH$
L_L	$0.509nH$
C_p	$0.105pF$

A SDD charge model was implemented by Keysight to represent the non-linear capacitor in the reverse and forward bias regions[5]. Assuming a gradient coefficient of 0.5, equation (4) describes the junction capacitance in the reverse-biased region.

$$C_r(v) = C_o \sqrt{\frac{V_0}{V_0 - v}} \quad v < V_0 \quad (4)$$

The charge can be obtained by integrating equation (4) with respect to the applied voltage (v) and considering that the integration constant $Q_r(V_0)$ is 0, as presented in equation (5).

$$Q_r(v) = -2C_o \sqrt{V_0(V_0 - v)} \quad v < V_0 \quad (5)$$

Equation (5) is limited to $v < V_0$; therefore a forward biased capacitance model is required. This model can be obtained by linearly extrapolating the model. The obtained capacitance model is valid for the forward and reverse bias region avoiding the discontinuity at $v = V_0$. The forward biased capacitance is presented in equation (6).

$$C_f(v) = C_r(\alpha V_0) + C'_r(\alpha V_0)(v - \alpha V_0) \quad v \geq \alpha V_0 \quad (6)$$

The forward region charge is obtained by integrating the forward capacitance considering an integration constant of $Q_f(\alpha V_0) = Q_r(\alpha V_0)$, this assures continuity between reverse and forward regions. Equation (7) models the forward region charge.

$$Q_f(v) = \frac{C_0}{\sqrt{1 - \alpha}} \left((v - \alpha V_0) + \frac{(v - \alpha V_0)^2}{4V_0(1 - \alpha)} \right) + Q_r(\alpha V_0) \quad (7)$$

TABLE III: C_j and R_s fitting Constants

I_0	n	C_0	V_0	α
$5.18\mu A$	1.262	$0.0216pF$	$0.863V$	0.987

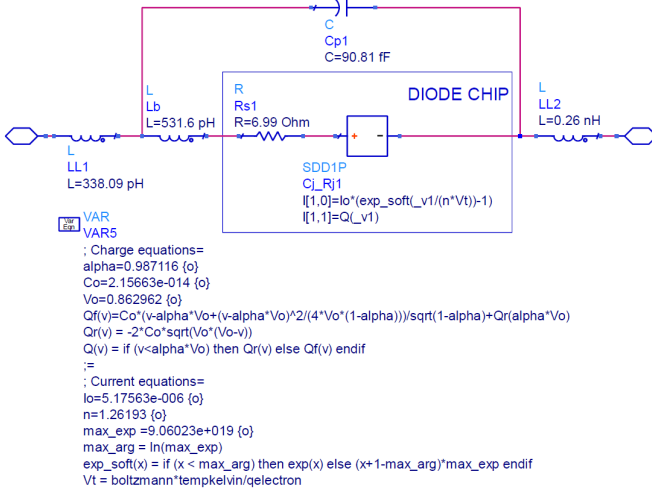

Fig. 7: Schematic of Schottky diode charge model

The final charge model can be expressed as in equation (8).

$$Q(v) = \begin{cases} Q_r(v), & \text{if } v < \alpha V_0 \\ Q_f(v), & \text{if } v \geq \alpha V_0 \end{cases} \quad (8)$$

The capacitance can be fitted by the data obtained of the imaginary part of (3). These data must be obtained at various bias voltage points. The fitting returns the value of C_0 , V_0 , α , which are summarized in Table III.

The resistance R_j model follows the same procedure using a current source described by equation (9).

$$I_j = V_j \Re\{Y_{11}\} = \frac{V_j}{R_j} \quad (9)$$

The current points, I_j , were be obtained for various bias voltage points. These data was fitted using the Schottky diode current as in equation (10).

$$I_j = I_o(e^{(V_j/nV_t)} - 1) \quad (10)$$

Where V_j is the junction voltage drop obtained by $V_j = V_D - R_s I_j$, I_o is the saturation current, and n is the ideality factor, and the thermal voltage V_t is equal to 26mV.

Table III summarizes all fitting constants of C_j and I_j curves.

The Schottky diode charge ADS model is shown in Figure (7).

In order to test the performance of the model, its large signal characteristic is compared to experimental measurements of the real diode $I_d - V_d$. As shown in Figure (8), the model agrees with the real diode measurements

III. RF RECTIFIER DESIGN AND SIMULATION

The rectifier, in general, is composed by diodes, a DC-pass filter and load. At high frequencies, diode Z_{in} has an

Fig. 8: Simulated and measured $I_d - V_d$ characteristics

Fig. 9: ADS Schematic for the input impedance value extraction

important role to the RF-DC conversion efficiency[11]. The input impedance is dependent on the operating frequency, the RF input power and the load resistance [6]. Adequate simulation of the circuit requires a large signal scenario; therefore the Large Signal S-Parameter (LSSP) simulator from ADS is employed to test the behavior of the rectifier circuit including variations in power levels and harmonics of the input signal. The simulation conditions were set to 10mW input power, up to 3 harmonic components, 1000 Ω load, and an operating frequency of 1900 MHz. To obtain the right impedance value the load must be isolated from the circuit. This was accomplished with a short circuit ideal transmission line. The ADS schematic is shown in Figure (9).

The value of the input impedance obtained by simulation under this conditions was $104.8 - j768.2 \Omega$. The Smith Chart shows Z_{in} in function of the frequency, in Figure (10).

Since the RF source impedance is 50Ω , a quarter-wave line transforms the feed line into 100Ω . The diode reactance is matched by a 1.43mm wide short circuit stub. At the output of the diode, a low pass filter, composed by radial stubs, rejects the odd order harmonics and AC signals that were not rectified by the diode [3]. The rectifier layout is presented in Figure (11).

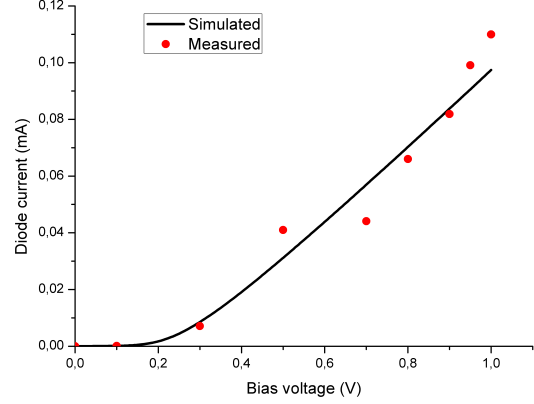
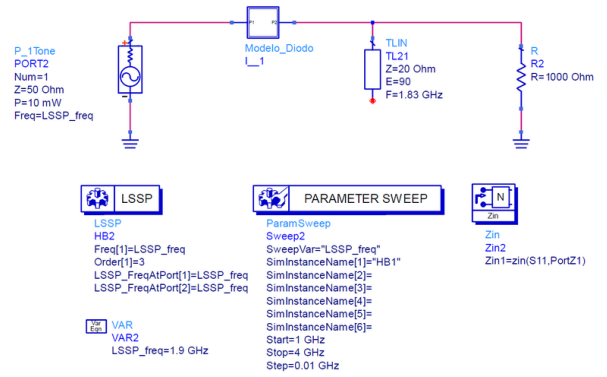
S_{11} evaluates how much power is reflected due to mismatch between source and diode impedances. LSSP evaluate the

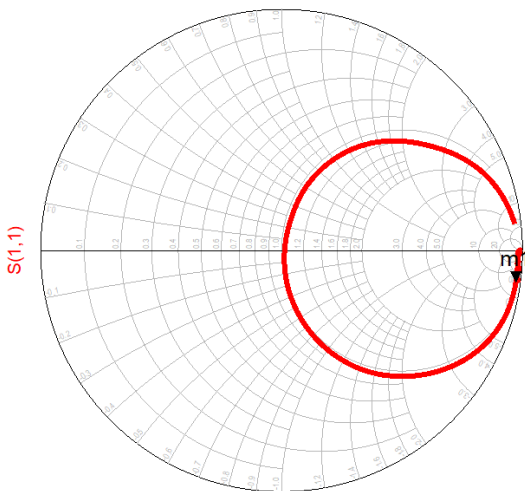

```

m1
indep(m1)=1.900E9
plot_vs(S(1,1), LSSP_freq)=0.981 / -7.578
=0
impedance = 105.364 - j740.074

```

Fig. 10: Input impedance simulation

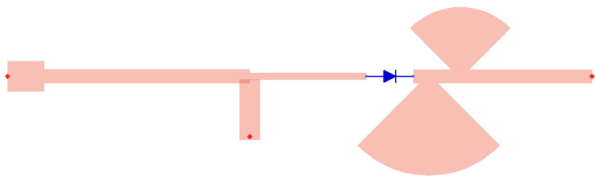

Fig. 11: Layout of the rectifier circuit

Fig. 12: Measured and simulated S_{11} of the circuit matching network

Fig. 13: Fabricated rectifier circuit

matching network performance through the simulation of S_{11} . Also, experimental measurements of S_{11} made by the VNA shows the actual performance of the rectifier circuit. Both simulated and measured results of S_{11} are shown in Figure 12. The measured insertion loss match very good with the simulated result with a load of 4000Ω . At the center frequency, the difference is about 10 MHz with -38.5 dB. The measured -10dB bandwidth insertion loss is 90 MHz, 40 MHz less than simulated. But, this result is enough to cover the GSM1900 band.

IV. RESULTS

The rectifier circuit was fabricated on a substrate with the same characteristics as the TRL calibration in section II. Figure (13) shows the fabricated rectifier circuit.

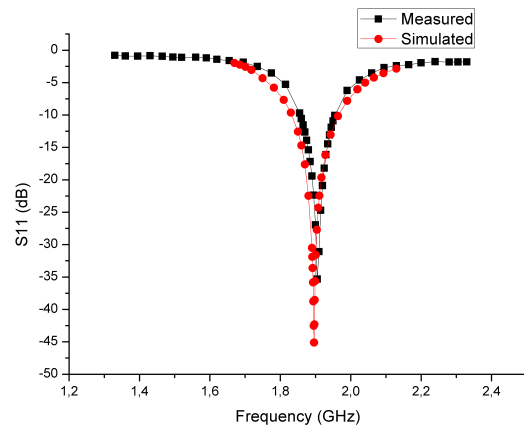
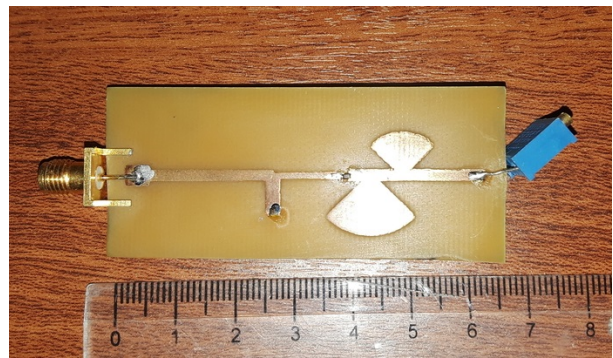
ADS Harmonic Balance simulator evaluated the performance of DC output voltage. Regarding the circuit RF to DC conversion efficiency, this can be defined as in equation (11) [3].

$$\eta = \frac{V_{OUT}^2}{P_{in} R_L} \quad (11)$$

where V_{OUT} is the DC output voltage and R_L is the load resistor. The input signal was generated by Agilent 8648B RF analog signal generator, and the output voltage was measured by Fluke 179 digital multimeter.

In order to obtain the maximum efficiency, the optimal operational load was obtained. The efficiency was analyzed as a function of the load at the working frequency, 1900 MHz, and 0 dBm input power, as shown in Figure (14). The efficiency reaches its maximum value with 2000Ω load.

Figure (15) shows the variation efficiency in function of the frequency. It takes account the optimum load value of 2000Ω and 0 dBm input power. The highest simulated efficiency

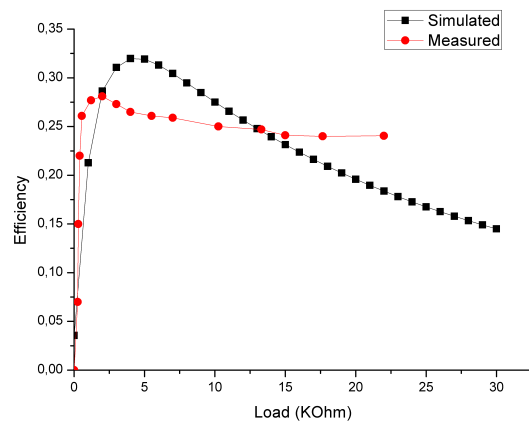

Fig. 14: Rectifier efficiency VS load

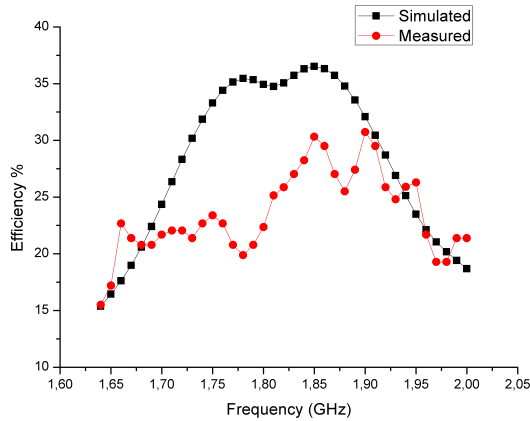

Fig. 15: Rectifier efficiency VS frequency

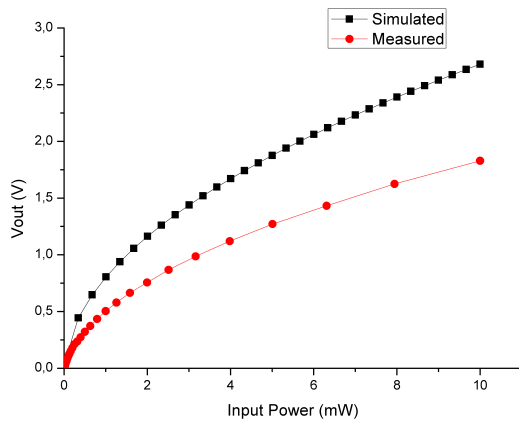

Fig. 16: Measured and simulated DC output voltage in function of input power

occurs at 1870 MHz with 37%, and 32% at 1900 MHz. The experimental measurements shows two peaks at 1850 MHz and 1910 MHz with 30% and 31% respectively. In the working frequency the efficiency reaches a 31%, 2% lower than the simulated result.

Finally the output DC voltage was evaluated in function of the input power as shown in Figure (16). In simulation and experimental measurements, the load was 540Ω and at

1900MHz. The simulated results are higher than the experimental ones. At 0 dBm (1mW), the simulated DC output voltage is 0.8V, but, the measured result is 0.5V, 37% below the expected. This may be due to a poor quality soldering and PCB fabrication. Furthermore, the assumed substrate loss tangent value was for 1 GHz, half the working frequency.

V. CONCLUSION

The paper presents a guideline to simulate a radio frequency rectifier using an approach focused for new low power applications. The rectifier model is based on real small signal S-parameter measurements of a Schottky diode, and it operates at the 3G band (1900 MHz). The work also explains in detail how to take advantage of ADS simulators to analyze large signal responses of non-linear devices. The simulation results are evaluated by measurements of a low cost fabricated rectifier.

REFERENCES

- [1] L. C. Tolga Soyata and W. Heinzelman, "Rf energy harvesting for embedded systems: A survey of tradeoffs and methodology," in *IEEE circuits and systems magazine*, February 2016, pp. 22 – 50.
- [2] J. R. S. Negin Shariati, Wayne S. T. Rowe and K. Ghorbani, "Multi-service highly sensitive rectifier for enhanced rf energy scavenging," in *Nature Publishing Group*, vol. 5, no. 9655, May 2015, pp. 1 – 5.
- [3] M. Zeng, "Differential topology rectifier design for ambient wireless energy harvesting," in *2016 IEEE International Conference on RFID Technology and Applications (RFID-TA)*, September 2016, pp. 97 –101.
- [4] Y. H. Liew and J. Joe, "Large-signal diode modeling—an alternative parameter-extraction technique," *IEEE Transactions on Microwave Theory and Techniques*, vol. 53, no. 8, pp. 1 –6, August 2005.
- [5] K. Technologies. (2011) Full model diode, with capacitance and resistance. [Online]. Available: <http://edadocs.software.keysight.com/display/ads2009/LSSP+Simulation+Description>
- [6] J. C. J. S. Jinwoo Shin¹, Mihui Seo and C. Cheon, "A compact and wideband circularly polarized rectenna with high efficiency at x-band," *Progress In Electromagnetics Research*, vol. 145, pp. 163 –173, March 2014.
- [7] —, "Diode modeling for rectenna design," in *Antennas and Propagation (APSURSI), 2011 IEEE International Symposium*, July 2011, pp. 163 –173.
- [8] K. Technologies. (2017, December) Network analysis applying the 8510 trl calibration for non-coaxial measurements. [Online]. Available: <http://literature.cdn.keysight.com/litweb/pdf/5091-3645E.pdf>
- [9] J. Fleury and O. Bernard, "Designing and characterizing trl fixture calibration standards for device modeling," *Applied Microwave & Wireless*, pp. 26 –42, October 2001.
- [10] D. M. Pozar, *Microwave Engineering*, 4th ed. Wiley, 2011.
- [11] Skyworks. (2003) Equivalent circuit for sms7630-0791f. [Online]. Available: <http://www.skyworksinc.com>