

**UNIVERSIDAD SAN FRANCISCO DE QUITO USFQ**

**Colegio de Ciencias y Ingeniería**

**Design of a flow perfusion biorreactor for human cell culture**

**José Nicolás Anguisaca Cartuche**

**Ingeniería Mecánica**

Trabajo de fin de carrera presentado como requisito  
para la obtención del título de  
Ingeniero mecánico

Quito, 26 de diciembre de 2020

**UNIVERSIDAD SAN FRANCISCO DE QUITO USFQ**

**Colegio de Ciencias y Ingeniería**

**HOJA DE CALIFICACIÓN  
DE TRABAJO DE FIN DE CARRERA**

**Design of a flow perfusion bioreactor for human cell culture**

**Jose Nicolas Anguisaca Cartuche**

**Marco León, M.sc**

Quito, 26 de diciembre de 2020



## © DERECHOS DE AUTOR

Por medio del presente documento certifico que he leído todas las Políticas y Manuales de la Universidad San Francisco de Quito USFQ, incluyendo la Política de Propiedad Intelectual USFQ, y estoy de acuerdo con su contenido, por lo que los derechos de propiedad intelectual del presente trabajo quedan sujetos a lo dispuesto en esas Políticas.

Asimismo, autorizo a la USFQ para que realice la digitalización y publicación de este trabajo en el repositorio virtual, de conformidad a lo dispuesto en la Ley Orgánica de Educación Superior del Ecuador.

Nombres y apellidos: José Nicolás Anguisaca Cartuche

Código: 00129090

Cédula de identidad: 1716561590

Lugar y fecha: Quito, 26 de diciembre de 2020

## ACLARACIÓN PARA PUBLICACIÓN

**Nota:** El presente trabajo, en su totalidad o cualquiera de sus partes, no debe ser considerado como una publicación, incluso a pesar de estar disponible sin restricciones a través de un repositorio institucional. Esta declaración se alinea con las prácticas y recomendaciones presentadas por el Committee on Publication Ethics COPE descritas por Barbour et al. (2017) Discussion document on best practice for issues around theses publishing, disponible en <http://bit.ly/COPETHeses>.

## UNPUBLISHED DOCUMENT

**Note:** The following capstone project is available through Universidad San Francisco de Quito USFQ institutional repository. Nonetheless, this project – in whole or in part – should not be considered a publication. This statement follows the recommendations presented by the Committee on Publication Ethics COPE described by Barbour et al. (2017) Discussion document on best practice for issues around theses publishing available on <http://bit.ly/COPETHeses>.

## RESUMEN

El siguiente informe describe el diseño de un biorreactor para cultivo celular con un flujo de bomba peristáltica. Se aplicaron criterios de ingeniería para lograr el diseño final del biorreactor, considerando presupuesto y material. Una vez elegido el diseño final se elabora un proceso de fabricación completo para cada componente. Durante el proceso de diseño, se aplican estándares de ingeniería para mantener la seguridad del operador y el cultivo celular. Las simulaciones de software de dinámica de fluidos computacional (CFD) COMSOL se realizan para validar los parámetros de diseño seleccionados, los resultados analíticos obtenidos coinciden con los resultados de las simulaciones. Se aplica un sistema automatizado para evitar resultados no deseados, el sistema de control se hizo para mantener constante el pH en el medio y el caudal en la bomba peristáltica, el sistema de control se realizó en el software de simulación PROTEUS con código ARDUINO. Los resultados analíticos coinciden con los resultados de las simulaciones, lo que verifica la eficacia de los cálculos de ingeniería.

**Palabras Clave:** Biorreactor de perfusión, Cultivo Celular, Bomba Peristáltica, Software COMSOL.

## ABSTRACT

The following project report describes the design of a bioreactor for cell culture with a peristaltic pump flow. Engineering criteria were applied to achieve the final design of the bioreactor, considering budget and material selection. Once the final design is chosen a complete manufacturing process is elaborated for each component. During the design process, engineering standards are applied to keep the safety of the operator and the cell culture. Software simulations of computational fluid dynamics (CFD) COMSOL are done to validate the selected design parameters. An automated system is being applied to prevent unwanted results, the control system was made to keep a constant pH and flow rate in the peristaltic pump, the control system was realized in software simulation PROTEUS with ARDUINO code to keep a constant pH and flow rate in the peristaltic pump. The results obtained match with the results of the simulations which verifies the effectiveness of the engineering calculations.

**Key Words:** Perfusion Bioreactor, Cell Culture, Peristaltic Pump, COMSOL Software

## TABLE OF CONTENTS

<b>INTRODUCTION .....</b>	<b>13</b>
<b>PROJECT MANAGEMENT.....</b>	<b>15</b>
PROJECT ACTIVITIES AND TASKS MANAGEMENT.....	15
PROJECT BUDGET .....	15
<b>ENGINEERING STANDARDS .....</b>	<b>17</b>
<b>DESIGN CONCEPTS .....</b>	<b>19</b>
BIOREACTOR SYSTEM COMPONENTS DISTRIBUTION.....	19
BIOREACTOR CHAMBER OPTIONS.....	21
BIOREACTOR CHAMBER CLOSING MECHANISM AND MATERIALS OPTIONS.....	24
RESERVOIR OPTIONS .....	25
RESERVOIR MATERIALS OPTIONS .....	28
BIOREACTOR CHAMBER AND RESERVOIRS CONNECTION/ATTACHMENT OPTIONS.....	28
<b>COMPONENTS AND MATERIALS SELECTION.....</b>	<b>31</b>
<b>DESIGN FOR MANUFACTURING .....</b>	<b>37</b>
<b>DESIGN REPORT .....</b>	<b>40</b>
<b>ENGINEERING ANALYSIS .....</b>	<b>42</b>
FLUID DYNAMICS ANALYSIS .....	42
ENERGY ANALYSIS FOR SYSTEM'S PRESSURE DROP .....	49
DESIGN OF EXPERIMENTS.....	52
CONTROL SYSTEM DESIGN .....	54
<b>PROTOTYPE TEST PLAN .....</b>	<b>71</b>
GEOMETRIC/PHYSICAL PROTOTYPE TEST.....	72
FLUID DYNAMICS PROTOTYPE TEST .....	73
<b>SAFETY THROUGH DESIGN .....</b>	<b>73</b>
<b>MAINTENANCE AND OPERATING MANUAL.....</b>	<b>79</b>

GENERAL DESCRIPTION AND FEATURES .....	79
LIST OF PARTS .....	79
SAFETY INFORMATION .....	82
GENERAL OPERATING NOTES .....	83
OPERATING VARIABLE RANGES .....	84
MAINTENANCE.....	84
USER RELEVANT ASSEMBLY DRAWINGS .....	85
<b>RESULTS .....</b>	<b>87</b>
FLUID DYNAMICS ANALYSIS .....	87
ENERGY ANALYSIS.....	95
DESIGN OF EXPERIMENTS.....	95
<b>DISCUSSION .....</b>	<b>98</b>
<b>CONCLUSIONS .....</b>	<b>100</b>
<b>FUTURE WORK.....</b>	<b>101</b>
<b>REFERENCES.....</b>	<b>102</b>
<b>APPENDIXES .....</b>	<b>105</b>
APPENDIX A.....	105
APPENDIX B.....	106
APPENDIX C.....	120
APPENDIX D.....	128
APPENDIX E .....	139
APPENDIX F .....	155
APPENDIX G.....	160
APPENDIX H.....	214

## TABLES INDEX

Table 1 Initial Budget for the designed system .....	15
Table 2 Additional budget the system may incur .....	16
Table 3 Engineering standards for the bioreactor system.....	17
Table 4 Weighted criteria method for design parameters.....	19
Table 5 Design evaluation for the bioreactor chamber design concepts .....	31
Table 6 Design evaluation for the reservoirs design concepts.....	33
Table 7 Design evaluation for the attachment/connection design concepts .....	35
Table 8 Not designed required components for bioreactor system operation .....	36
Table 9 Parts list and manufacturing method .....	37
Table 10 Bioreactor system engineering analysis roadmap.....	40
Table 11 Relevant values obtained from literature and client's specifications .....	44
Table 12 Bioreactor system relevant components dimensions and operating conditions .....	44
Table 13 Prototype test plan guidelines .....	72
Table 14 General risks identification.....	74
Table 15 5x5 Risk Matrix quantitative evaluation.....	75
Table 16 Tabulated assessment for 12 most important risks .....	76
Table 17 Final risk control matrix .....	77
Table 18 Bioreactor system list of parts .....	79
Table 19 Analytical analysis parametric study with flowrate variation .....	87
Table 20 Analytical analysis parametric study with bioreactor chamber diameter variation..	89
Table 21 System Pressure drop EES results .....	95
Table 22 Experiment design parameters.....	96

## FIGURES INDEX

Figure 1 Bioreactor system components distribution option 1 .....	20
Figure 2 Bioreactor system components distribution option 2 .....	21
Figure 3 Bioreactor chamber option 1 .....	22
Figure 4 Bioreactor chamber option 2 .....	23
Figure 5 Bioreactor chamber option 3 .....	24
Figure 6 Reservoir concept option 1 .....	26
Figure 7 Reservoir concept option 2.....	27
Figure 8 Reservoir concept option 3.....	28
Figure 9 Bioreactor chamber and reservoir attachment option 1.....	29
Figure 10 Bioreactor chamber and reservoir attachment/connection option 2.....	30
Figure 11 Bioreactor chamber and reservoir attachment/connection option 3.....	30
Figure 12 Final prototype design for the bioreactor chamber.....	32
Figure 13 Final prototype design for the reservoir .....	34
Figure 14 Final prototype design for the tray .....	35
Figure 15 Bioreactor sealing top cap manufacture process flow chart.....	38
Figure 16 Bioreactor sealing top cap process sheet.....	39
Figure 17 Bioreactor chamber and reservoir compact distribution prototype.....	41
Figure 18 Final prototype control system layout.....	42
Figure 19 Close up look at structural members distribution of the scaffold.....	43
Figure 20 Flow past a cylinder.....	45
Figure 21 Variation of shearing stress at the wall over the circumference of a circular cylinder .....	45
Figure 22 Geometry of the bioreactor chamber and scaffold structural members sample seen from a side.....	47



Figure 23 Portion of the geometry applied an extra-fine physics-controlled mesh.....	48
Figure 24 Geometry of the bioreactor chamber and scaffold structural members three-dimensional simulation .....	49
Figure 25 Simplified Bioreactor system to be analyzed .....	51
Figure 26 Control diagram of the bioreactor system .....	55
Figure 27 Bioreactor system peristaltic pump .....	56
Figure 28 YF-S201 Hall-Effect Water Flow Sensor.....	57
Figure 29 Flowrate control system components connection layout.....	58
Figure 30 Different substances pH range.....	59
Figure 31 Analog pH sensor - Meter kit .....	59
Figure 32 pH control system circuit connection layout.....	60
Figure 33 Pulse generator setup for flowrate control simulation.....	61
Figure 34 Proteus oscilloscope sample reading of a pulse .....	62
Figure 35 Servomotor simulation setup.....	62
Figure 36 Code section added to solve flow frequency in simulation.....	63
Figure 37 First time case simulation for the flow control system.....	64
Figure 38 Second time case simulation for the flow control system.....	65
Figure 39 Third time case simulation for the flow control system .....	65
Figure 40 Fourth time case simulation for the flow control system .....	66
Figure 41 Pulse generator case simulation for the flow control system .....	67
Figure 42 DC generator setup for pH control system simulation .....	68
Figure 43 First case simulation for the pH control system .....	69
Figure 44 Second case simulation for the pH control system.....	70
Figure 45 pH control system simulation with serial monitor readings.....	71
Figure 46 Bioreactor Chamber Assembly.....	85

Figure 47 Medium Reservoir Assembly .....	86
Figure 48 Flowrate vs wall shear stress .....	88
Figure 49 Flowrate vs entrance length.....	88
Figure 50 Flowrate vs Reynolds number .....	89
Figure 51 Bioreactor chamber diameter vs wall shear stress.....	90
Figure 52 Bioreactor chamber diameter vs Reynolds number.....	90
Figure 53 Bioreactor chamber diameter vs Freestream velocity .....	91
Figure 54 Flow velocity distribution throughout the bioreactor chamber and around the scaffold structural members .....	92
Figure 55 Close up look of the Flow velocity distribution around the scaffold structural members.....	92
Figure 56 Wall shear stress vs arc length at the surface of the scaffold structural members ..	93
Figure 57 Perspective view of the flow velocity distribution throughout the bioreactor chamber and around the scaffold structural members .....	93
Figure 58 XZ plane view of the flow velocity distribution throughout the bioreactor chamber and around the scaffold structural members .....	94
Figure 59 Wall shear stress distribution at the surface of the scaffold structural members ....	94
Figure 60 Experiment model setup .....	97
Figure 61 Laminar flow ink trace paths in experiment model.....	97

## INTRODUCTION

One of the main goals in medicine is to develop methods that allow humans to extend their lifespan with a good quality of life. Among several medicine leap discoveries, tissue engineering plays a big role in achieving the previously mentioned goal. Tissue engineering mainly focuses on tissue culture which is the growth and maintenance of live cells outside the body (Slack, 2018, p. 49). Cell culture has been in development since the early 20<sup>th</sup> century and has been a relatively common process since 1950 when complex media, sterile disposable containers, and antibiotics became commercially available (Slack, 2018, p. 49). Cell culture has been dealing with manipulation of the biophysical environment where cells are meant to reproduce, which has been crucial for tissue engineering success (Grossemey, Chan, & Doran, 2020). Nowadays, various areas are of most interest in the development of tissue engineering which according to the National Institute of Biomedical Imaging and Bioengineering are controlling stem cells through their environment, implanting human livers in mice, cartilage restoration, and engineering mature bone stem cells (2019).

There are many techniques for cell culture, however, one of the most common practices is the three-dimensional method. For the three-dimensional method, it is required in most cases the use of a bioreactor system. The bioreactor is a device that provides a controlled sterile environment for the development of engineered tissue (Abousleiman & Sikavitsas, 2006, p. 250). It provides the cultured cells with similar physiological conditions and gives mechanical stimulations to ensure mass transfer and nutrients transport between the cells to their proliferation (Abousleiman & Sikavitsas, 2006, p. 250). Currently, state-of-the-art perfusion bioreactors are using high-technology equipment with built-in sensors for controlling the conditions inside a disposable bag where the cells are placed to grow. As an example, one can take the WAVE Bioreactor manufactured by GE Healthcare. This bioreactor uses a rocking mechanism that provides motion to a disposable plastic bag that is

partially filled with culture media and inflated to rigidity (USA Patent No. US009428724B2, 2016). This rocking motion is the one that allows a proper mass transfer and promotes agitation, which are paramount characteristics for a good bioreactor performance (USA Patent No. US009428724B2, 2016). The non-disposable part of the equipment is provided with sensors that give readings and control over the aeration rate, rocking speed, pH control, and temperature to which the cells are exposed (GE Healthcare, 2008).

This project will be developed for the College of Science and Engineering specifically for Professor Jose Alvarez, Ph.D. The present bioreactor system will serve as a tool for further research and development in the bioengineering field. Currently, state-of-the-art bioreactors as the one mentioned before, include a cell culture process that demands either big storage facilities or voluminous laboratory instruments, both adverse factors. Also, some processes demand more time than what is required when treating patients that need tissue transplants. This is why this project mainly focuses on solving the spacing and timing issues that human cell culture processes are currently facing. To solve the former problems several design options will be presented in this document, which have gone through a careful evaluation until reaching a final prototype. This prototype takes into account the following parameters: the size of the equipment, operation fidelity, ease of assembly, cleanability, and the cost of production and maintenance. Additionally, the prototype complies with physical requirements such as the full development of the flow in the bioreactor chamber, an appropriate amount of shear stress over the cells, and a proper pressure drop around the system. These physical requirements have been achieved by an analytical analysis using fluid dynamics and energy principles and have been proved by numerical methods using CFD analysis as well as a designed experiment to illustrate the involved phenomena and behavior of the system. This engineering analysis plus the project management and development will be presented in the following sections.

## PROJECT MANAGEMENT

### Project activities and tasks management

This project has been carefully planned in terms of time and workload distribution among its participants. This plan has been carried out with the aid of a Gantt chart in which can be found the tasks, meetings, deliverables, and the people who have participated or have been responsible for them. This Gantt chart can be found in Appendix A.

### Project budget

An approach to the budget required for a possible implementation process is shown below.

*Table 1 Initial Budget for the designed system*

Component	Hrs	Rate	Units	\$/unit	Subtotal	Taxes	Total
<b>Bioreactor system</b>							
Sealing top cap	2.20	\$ 15.90	1	\$ 35.00	\$ 35.00	\$ 4.20	\$ 39.20
Sealing bottom cap	3.15	\$ 14.30	1	\$ 45.00	\$ 45.00	\$ 5.40	\$ 50.40
Bioreactor chamber	24.55	\$ 4.90	1	\$ 120.00	\$ 120.00	\$ 14.40	\$ 134.40
Reservoir cap	24.35	\$ 6.16	1	\$ 150.00	\$ 150.00	\$ 18.00	\$ 168.00
Reservoir	5.33	\$ 18.80	1	\$ 100.00	\$ 100.00	\$ 12.00	\$ 112.00
System tray	5.33	\$ 15.00	1	\$ 80.00	\$ 80.00	\$ 9.60	\$ 89.60
Connection tubes			1	\$ 68.43	\$ 68.43	\$ 8.21	\$ 76.64
Peristaltic pump			1	\$ 303.99	\$ 303.99	\$ 36.48	\$ 340.47
Worm drive hose clamp			6	\$ 1.19	\$ 7.14	\$ 0.86	\$ 8.00
Arduino Uno			1	\$ 23.00	\$ 23.00	\$ 2.76	\$ 25.76
Arduino Nano			1	\$ 20.70	\$ 20.70	\$ 2.48	\$ 23.18
YFS201 water flow sensor			1	\$ 3.73	\$ 3.73	\$ 0.45	\$ 4.18
Analog pH sensor kit			1	\$ 29.50	\$ 29.50	\$ 3.54	\$ 33.04
Plastic ball valve			1	\$ 0.90	\$ 0.90	\$ 0.11	\$ 1.01
Led kit			1	\$ 4.50	\$ 4.50	\$ 0.54	\$ 5.04
LCD (LM016L)			1	\$ 6.50	\$ 6.50	\$ 0.78	\$ 7.28
220-ohm resistor			2	\$ 0.19	\$ 0.38	\$ 0.05	\$ 0.43
Micro servo motor			1	\$ 11.99	\$ 11.99	\$ 1.44	\$ 13.43
					\$ 1,010.76		\$ 1,132.05

The budget shown above reflects prices for all the parts necessary for the designed perfusion bioreactor system. Yet, due to the pandemic circumstances in which this project takes place, Ecuadorian market prices were not feasible to gather for some of the

components. Therefore, applying all engineering knowledge and the ASME code of ethics, the most thorough analysis possible is presented.

*Table 2 Additional budget the system may incur*

Component	N/A	N/A	Units	\$/unit	Total
<b>Equipment</b>					
Sindoh 3DWOX Printer			1	\$ 2,499.35	\$ 2,499.35
PLA filament			1	\$ 20.00	\$ 20.00
PETG filament			1	\$ 40.00	\$ 40.00
VWR CO2 incubator			1	\$ 6,385.59	\$ 6,385.59
					\$ 8,944.94
<b>Others</b>					
Unforeseen costs				\$ 250.00	\$ 250.00
					\$ 250.00

In this proposal, a complementary budget is shown. There is equipment that, because of the dimensions of the designed bioreactor system and some client requirements, will require certain special conditions. That is why a powerful and very accurate 3D printer is recommended, like the Sindoh 3DWOX. The same applies to the CO2 incubator, which could potentially be replaced with a bigger one if there is more scientific interest and investment in the project.

## ENGINEERING STANDARDS

*Table 3 Engineering standards for the bioreactor system*

<b>Standard</b>	<b>Title</b>	<b>Cost</b>
ISO 9001:2015	Quality management systems — Requirements	\$ 155.67
ISO 13485:2016	Medical devices — Quality management systems — Requirements for regulatory purposes	\$ 178.23
FDA 21 CFR Part 820	Quality System Regulation (QSR)	-
ISO 17665- 1:2006	Sterilization of health care products — Moist heat — Part 1: Requirements for the development, validation, and routine control of a sterilization process for medical devices	\$ 178.23
ISO 10993- 1:2018	Biological evaluation of medical devices — Part 1: Evaluation and testing within a risk management process	\$ 178.23
ASTM F1980 -16	Standard Guide for Aging of Sterile Barrier for Medical Devices	\$ 52.00
ASTM D4169 -16	Standard Practice for Performance Testing of Shipping Containers and Systems	\$ 58.00

The present engineering standards are useful in different segments of the project. Most of them, however, will become pertinent once the actual manufacturing and production process takes place. A dash (-) is used to represent an FDA standard that was a varied

conglomerate of norms, each one with a different price. Moreover, a simple yet understandable breakdown is shown below.

- The standards ISO 9001:2015, ISO 13485:2016, and CFR 21 Part 820 are applicable for suppliers of raw materials for components in direct contact with the medium and scaffold. It can be considered as supplier qualifications.
- The standards ISO 17665-1:2006 is applicable for autoclave sterilization of materials, to ensure risk-free cell cultivation.
- The standards ISO 10993-1:2018 is applicable for qualifying and regulating the biological performance of raw materials of polymeric nature.
- The standards ASTM F1980 -16 is applicable when testing the designed perfusion bioreactor system integrity.
- The standards ASTM D4169 -16 is applicable when needing a performance test. In other words, it is useful when testing "the ability of shipping units to withstand the distribution environment" (American Society of Testing and Materials, 2020)

It is important to mention that for the specific biophysical and biochemical interactions that will undergo the designed system, qualification guidelines can be found in the *US Pharmacopeia*, which enumerates some crucial considerations like total organic carbon (TOC) (<643>), conductivity (<645>), pH (<791>), particulate matter (<788>), and so on. (Weber, A., De Wilde, D., Chaussin, S., Adams, T., Gerighausen, S., Greller, G., & Fenge, C., 2014)



## DESIGN CONCEPTS

The design of the bioreactor system needs to comply with various parameters. To determine the degree of importance of each parameter, a weighted criteria method has been performed as seen in the following table:

*Table 4 Weighted criteria method for design parameters*

Size > fidelity > Cleanable = Design for Assembly (DFA) > Replicability > Cost
--

Criteria	Size	Fidelity	Cleanable	DFA	Replicability	Cost	$\Sigma +1$	Results
Size		1	1	1	1	1	6	0.286
Fidelity	0		1	1	1	1	5	0.238
Cleanable	0	0		0.5	1	1	3.5	0.167
DFA	0	0	0.5		1	1	3.5	0.167
Replicability	0	0	0	0		1	2	0.095
Cost	0	0	0	0	0		1	0.048
						Sum	21	1

Once the order of importance of the design parameters is established as seen in Table 4, the design proposals can be evaluated to be further selected. In the following paragraphs, several design proposals regarding the whole system distribution as well as the design of specific components are presented.

### Bioreactor system components distribution

The system has three main components which are the bioreactor perfusion chamber, two medium reservoirs, and a peristaltic pump. However, the distribution of these components may vary to comply with the client requirements. Two distribution setups have been developed and are described below.

- **System distribution option 1**

This set up has two reservoirs connected in series, which are located independently from the bioreactor chamber. They will be placed in between the bioreactor chamber outlet and the peristaltic pump as seen in the following figure:

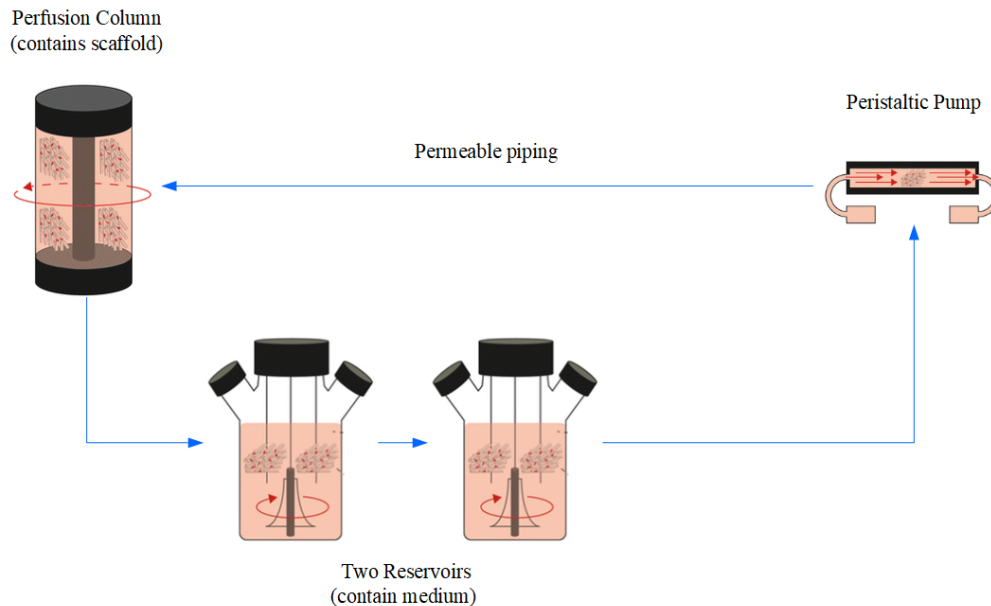

*Figure 1 Bioreactor system components distribution option 1*

- **System distribution option 2**

This set up distribution of the components has two reservoirs connected in series. However, they are placed close to the bioreactor chamber, which will provide a compact design. This setup could be complemented with the use of a tray that will keep the bioreactor chamber and the reservoirs nearby, which could improve its transportability. A more general view of this setup is shown in the following figure:

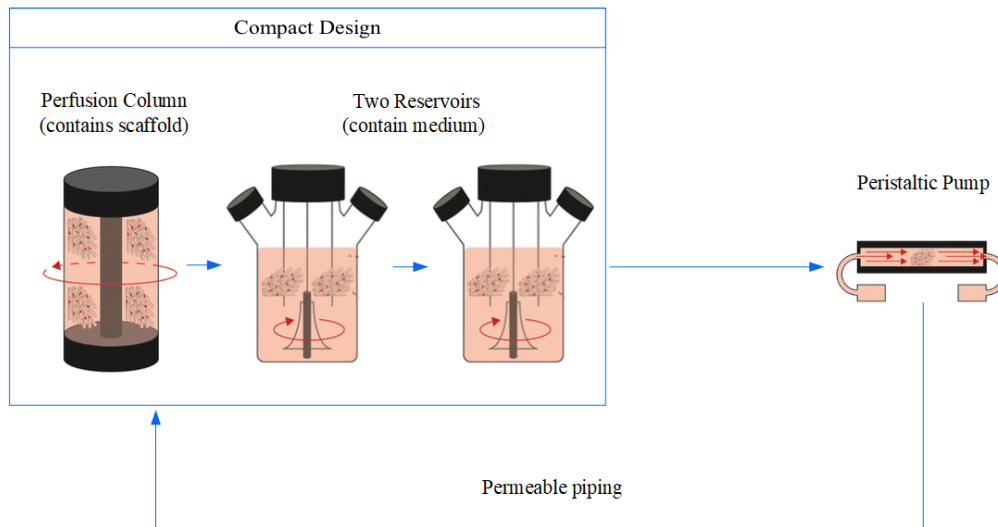

*Figure 2 Bioreactor system components distribution option 2*

### **Bioreactor chamber options**

The bioreactor chamber is a key component since it is where the scaffold with the human cells will be placed. To have a successful human cell growth in the scaffold, it is required that the nutritious medium flow achieves a fully developed condition before it reaches the scaffold. To achieve a fully developed flow inside a tube or pipe it must have a minimum length called entrance length, which depends on the characteristic of the flow (Reynolds number) and the diameter of the pipe or tube. Due to space constraints, the entrance length needs to be optimized, which is why various positions as well as shapes have been considered to comply with the requirements. In the following points various chamber options are described:

- **Bioreactor chamber option 1**

This option presents the bioreactor chamber that will be placed in a vertical position. The chamber will have two semi-spheric shape caps for both inlet and outlet. The Scaffold will hold into place by the semi-spheric shape that the bottom cap provides, which will prevent the scaffold to slide further down. This bioreactor chamber can be seen with more detail in the following figure:

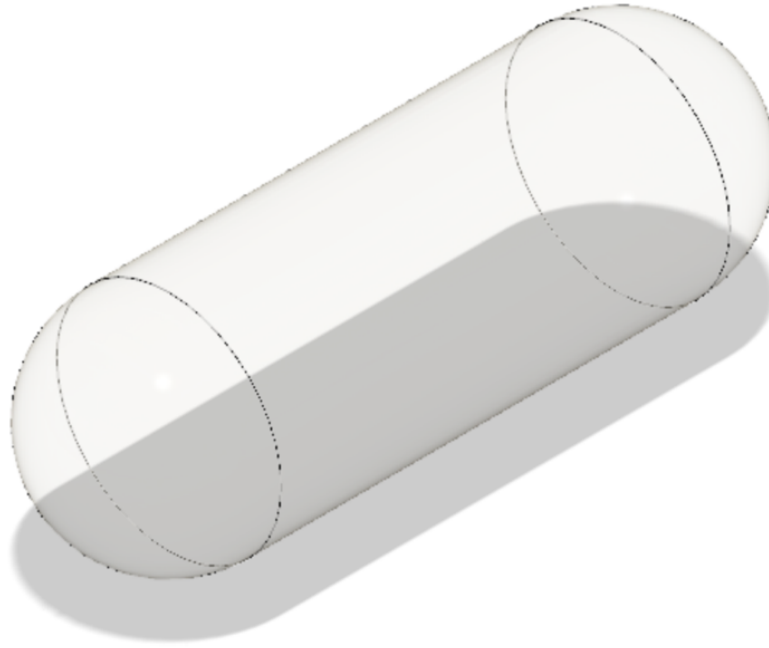
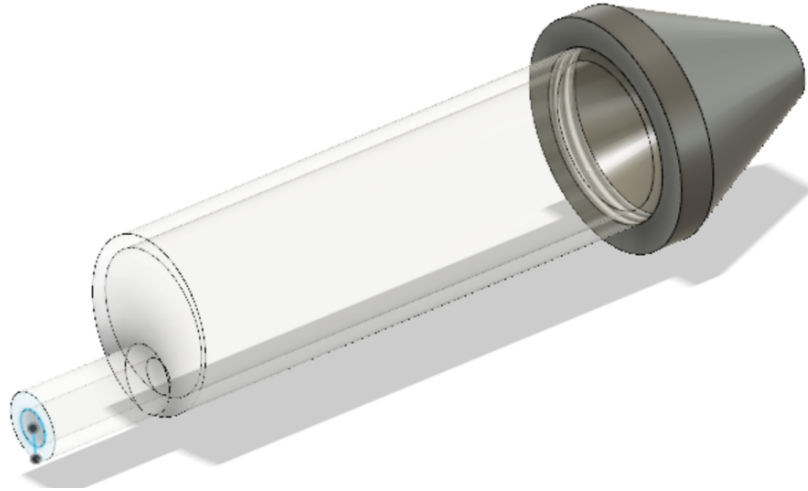

*Figure 3 Bioreactor chamber option 1*

*Source: Fusion 360*

- **Bioreactor chamber option 2**

This option presents the bioreactor chamber with a tilted position to the horizontal. The inlet side of the chamber will have more elevation than the outlet. In this option, there will be one tapered conic-shaped cap at the inlet and for the bottom of the chamber the side of the wall that faces upwards will converge inwards in a smooth fashion so this will serve as a support and a stop for the scaffold. This chamber design can be seen with more detail in the following figure:

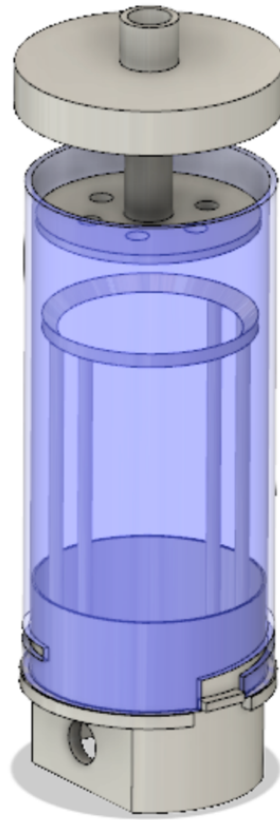

*Figure 4 Bioreactor chamber option 2*

*Source: Fusion 360*

- **Bioreactor chamber option 3**

This bioreactor chamber will be placed in a vertical position. The inlet will have a funnel that will concentrate the flow. The nutritious medium will be distributed through a shower-like mechanism and then reach the scaffold. The scaffold will be held in place by the bottom part of the perfusion chamber. Finally, the flow will evacuate through a hole located in the base. This chamber design can be seen with more detail in the following figure:



*Figure 5 Bioreactor chamber option 3*

*Source: Fusion 360*

### **Bioreactor chamber closing mechanism and materials options**

#### **Closing mechanism options:**

- Inlet and outlet threaded caps
- Inlet and outlet press-fitted caps

#### **Inlet and outlet caps materials options:**

- Stainless Steel
- Aluminum

#### **Chamber walls materials options:**

- Acrylic
- Polymeric plastic
- Glass

## **Reservoir options**

According to the customer requirements, the bioreactor system should have 2 reservoirs of medium to be easier to change the medium and clean the system. Also, it has to be considered that the changing/cleaning of the medium process has to be carried out at a laminar flow chamber which also gives some constraints when designing the ports that the reservoirs will have. Considering the previous constraints, three design concepts have been proposed and are described below:

- **Reservoir option 1**

This reservoir proposal joins the two reservoirs into one cylinder, and they are divided by a diagonal wall that goes from the bottom to the top, giving as a result an upper and a bottom reservoir system. This reservoir design intends to connect the bioreactor chamber on top of it while directly lying above the upper reservoir. Each reservoir will have one outlet and one inlet and each of them will be equipped with a catheter kind of valve that will allow the connection of a syringe to extract and charge medium to the reservoir. The reservoir will also have an entrance for filtered oxygen at the top next to the bioreactor chamber entrance. This oxygen entrance will be shared for the two reservoirs. For further clarification the reservoir proposal is presented in the following figure:



*Figure 6 Reservoir concept option 1*

*Source: Fusion 360*

- **Reservoir option 2**

This reservoir proposal presents two containers that will be connected in series with a plastic ball valve between them. Each container will have 5 entrances. Two of them located at the front and back of the container that will be part of the main circulation system, the other two ports will be located at one side of the container and they will have an angle and closed with a tooth cap injection vials rubber plug that allows the entrance of a syringe for charging and discharging medium at each port respectively. The last port will be placed on top of the reservoir and it will be the filtered oxygenation entrance. This reservoir proposal can be place on a tray that will hold as a whole the bioreactor chamber and the two reservoirs. For more details of the presented reservoir proposal refer to the following figure:



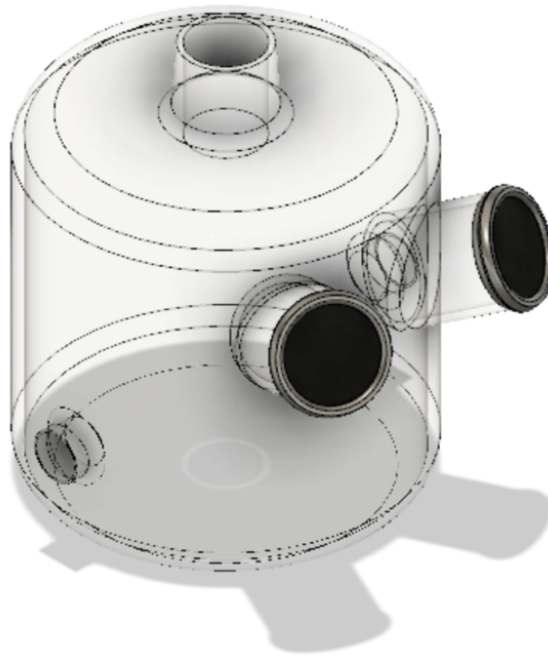
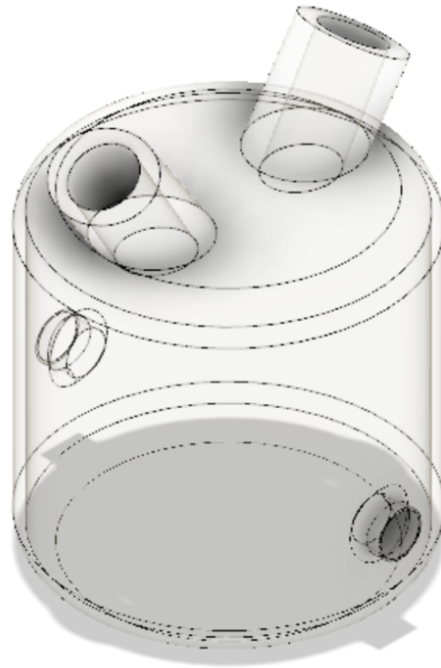

*Figure 7 Reservoir concept option 2*

*Source: Fusion 360*

- **Reservoir option 3**

This reservoir proposal is mainly a flask that will have two main entrances. One of the entrances will be the filtered oxygen entrance and the other will be cover with a threaded cap and will be used for charge and discharge the medium. These two entrances will be located at the top of the flask but angled to opposite sides. Refer to the following figure for further details:



*Figure 8 Reservoir concept option 3*

*Source: Fusion 360*

### **Reservoir materials options**

For the reservoir material, one main characteristic has been taken into account and that is that the material that will constitute the reservoir has to be transparent. For this reason, the following materials are taken into consideration:

- Acrylic
- Glass
- Polymeric plastic

### **Bioreactor chamber and reservoirs connection/attachment options**

Since one of the main goals of the project is to have a compact design especially when dealing with the bioreactor chamber and the reservoirs two proposals on this matter have been made:

- **Attachment option 1**

This option uses Option 1 of the reservoir exposed above and attaches the bioreactor chamber directly on top of the reservoir, so the two components merge into one solid assembly. This option of attachment can be seen in the following figure:

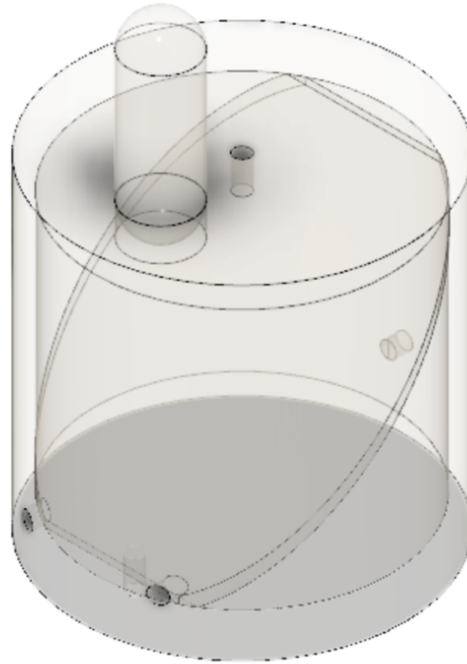
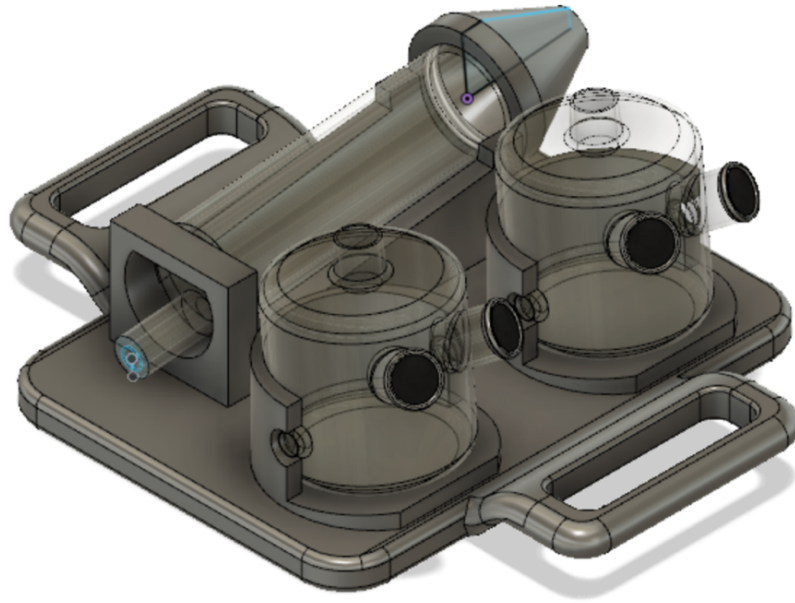

*Figure 9 Bioreactor chamber and reservoir attachment option 1*

*Source: Fusion 360*

- **Attachment/connection option 2**

This second option uses a tray that will hold the bioreactor chamber and the two reservoirs connected in series in one place. This option provides the advantage of the mobility of the components since the tray has handles that will help with this task. The presented attachment option can work with any of the bioreactor chamber proposals and with the second and third reservoir proposals. For further clarification see the following figure:

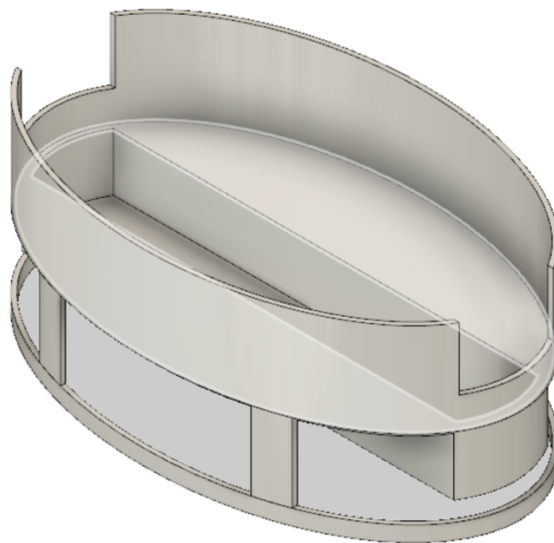

*Figure 10 Bioreactor chamber and reservoir attachment/connection option 2*

*Source: Fusion 360*

- **Attachment option 3**

This option presents a tray that will contain the perfusion column and the two bioreactors in the middle. Each of the three components will be distributed along the elongated middle-section. The wall helps to maintain everything in place and the whole structure is designed to be as sturdy, and compact, as possible.



*Figure 11 Bioreactor chamber and reservoir attachment/connection option 3*

*Source: Fusion 360*

## COMPONENTS AND MATERIALS SELECTION

In the previous section, various design concepts for different components of the bioreactor system has been presented, as well as some material, and functionality options for the designs. Based on the criterion shown in Table 4 along with the client's input, the design concepts presented before, have been evaluated until reaching a final prototype design.

Starting the selection analysis of the bioreactor chamber design concept options the following table has been developed. The complete design criteria analysis can be found in Appendix F

*Table 5 Design evaluation for the bioreactor chamber design concepts*

<b>Concept</b>	<b>Size</b>	<b>Fidelity</b>	<b>Cleanable</b>	<b>DFA</b>	<b>Replicability</b>	<b>Cost</b>	<b><math>\Sigma</math></b>	<b>Results</b>
Option 1	0.048	0.040	0.028	0.028	0.016	0.008	0.167	3
Option 2	0.143	0.119	0.083	0.083	0.048	0.024	0.500	1
Option 3	0.095	0.079	0.056	0.056	0.032	0.016	0.333	2

From Table 5 it can be seen that the design option 2 is the one that better complies with the design parameters. However, taking into account the experience input provided by the client it has been decided to use some of the characteristics of design option 3 and implemented to design option 1, giving as a result the following final bioreactor chamber prototype.



*Figure 12 Final prototype design for the bioreactor chamber*

*Source: Fusion 360*

The final prototype design for the bioreactor chamber shown in Figure 12 features a 1 cm internal diameter, a length of 14.5 cm, and a total operational volume of 11.39 cm<sup>3</sup>. The total length of the bioreactor including the inlet and bottom caps is 18.5 cm. The dimensions of this final prototype have been carefully determined after an engineering and calculations analysis. The top and bottom caps are threaded and have O-rings at the surface of contact with the chamber to ensure a hermetic seal. The sealing method selection has been taken after consulting with the client. For further clarification, of the design of the bioreactor chamber and its caps refer to Appendix B to see their respective drawings.

Regarding the selection of the materials for the bioreactor chamber, it has been chosen that the middle chamber section it is going to be manufactured out of acrylic PMMA. This decision has been made after consulting the client and due to the material properties. The acrylic PMMA has been widely used for medical purposes such as dentures, bone implants, and medical instruments due to its biocompatibility (Wasserman, 2019). However, for the manufacture of this component, the important characteristics of this material are that it is resistant to temperature stresses, chemical reactions, and bioprocesses (Wasserman, 2019).

Another advantage is that this material is easy to process and has a low cost (Wasserman, 2019). These characteristics make the acrylic PMMA a suitable choice since the bioreactor chamber will be placed inside an incubator at 37 degrees Celsius and bioprocesses will occur inside.

Regarding the material for the caps of the bioreactor chamber, after reviewing the options with the client and checking the properties of the materials previously proposed, it has been decided that the caps will be manufactured out of 316 stainless steel. This stainless-steel type has been chosen since it has a molybdenum addition which makes it more resistant to corrosion especially when dealing with saline or chloride exposed environments (Eagle Stainless Tube & Fabrication, Inc., n.d.). The 316 stainless steel also has the advantage of having excellent forming and machining properties as well as being suitable for welding (Eagle Stainless Tube & Fabrication, Inc., n.d.).

Now for the selection analysis of the reservoir design concept options, the following table has been developed. The complete design criteria analysis can be found in Appendix F

*Table 6 Design evaluation for the reservoirs design concepts*

<b>Concept</b>	<b>Size</b>	<b>Fidelity</b>	<b>Cleanable</b>	<b>DFA</b>	<b>Replicability</b>	<b>Cost</b>	<b><math>\Sigma</math></b>	<b>Results</b>
Option 1	0.119	0.099	0.069	0.069	0.040	0.020	0.417	1
Option 2	0.119	0.099	0.069	0.069	0.040	0.020	0.417	1
Option 3	0.048	0.040	0.028	0.028	0.016	0.008	0.167	2

From Table 6 it can be seen that the designs option 1 and 2 are the ones that better comply with the design parameters. Taking into account the experience input provided by the client it has been decided to use some of the characteristics of both designs and merge them to have the following final reservoir prototype.

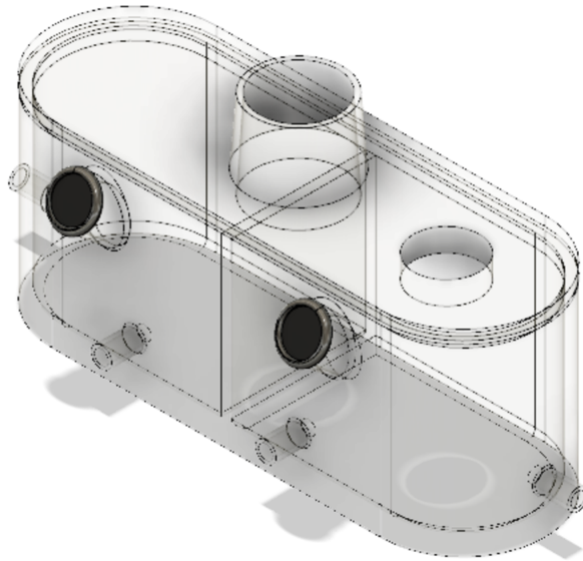

*Figure 13 Final prototype design for the reservoir*

*Source: Fusion 360*

The final prototype design for the reservoir shown in Figure 13 has a more compact design since it compresses together two reservoir compartments into a single component. The communication between the two reservoir compartments is done by a piece of tube that connects the two front ports, and it has a plastic ball valve to ensure that no flow passes when the operator needs to change the nutritious medium. It features a maximum length of 15 *cm*, a width of 5 *cm*, a maximum height of 8 *cm*, and a total operational volume of 239 *cm*<sup>3</sup>. The dimensions of this final prototype have been carefully determined considering the client's specifications that the total volume of the reservoirs has to be at least 3 times greater than the volume of the bioreactor chamber. The top cap is press-fitted and has an O-ring at the surface of contact with the reservoir to ensure a hermetic seal. The sealing method selection has been taken after consulting with the client. For further clarification, of the design of the reservoir and its cap refer to Appendix B to see their respective drawings.

Due to the client's specifications that the reservoir must be translucent, it has been decided that the reservoir will be manufactured out of acrylic PMMA. This material is the same that will constitute the chamber of the bioreactor, and for the reservoir, it has been



chosen due to its optical translucent properties in addition to the previously mentioned medical characteristics that the acrylic PMMA possesses.

Continuing with the design selection process, the attachment/connection options are evaluated, and the results are presented in the following table. The complete design criteria analysis can be found in Appendix F

*Table 7 Design evaluation for the attachment/connection design concepts*

<b>Concept</b>	<b>Size</b>	<b>Fidelity</b>	<b>Cleanable</b>	<b>DFA</b>	<b>Replicability</b>	<b>Cost</b>	<b><math>\Sigma</math></b>	<b>Results</b>
Option 1	0.119	0.099	0.069	0.069	0.040	0.020	0.417	1
Option 2	0.119	0.099	0.069	0.069	0.040	0.020	0.417	1
Option 3	0.048	0.040	0.028	0.028	0.016	0.008	0.167	2

From Table 7 it can be seen that the designs option 1 and 2 are the ones that better comply with the design parameters. However, after presenting these options to the client, he has decided that design option 2 will serve better for the transportability of the components. The client has made his decision based on his experience. Considering the final prototype design for the bioreactor chamber and the reservoir, the final prototype design for the components tray is shown in the following figure.

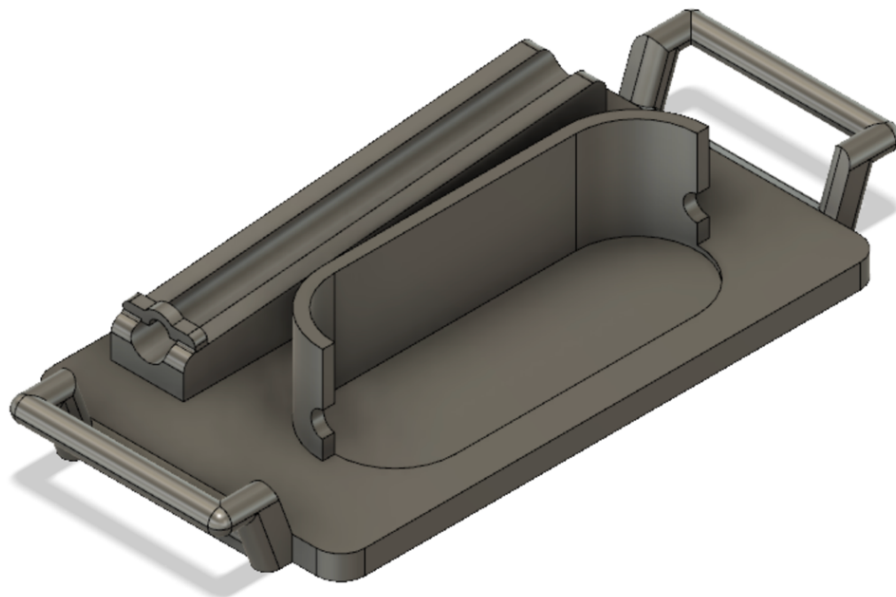

*Figure 14 Final prototype design for the tray*

*Source: Fusion 360*

As seen in Figure 14 the tray prototype has been updated to hose the new bioreactor chamber and reservoir designs. Furthermore, it has been decided that this tray will be manufactured out of PLA due to its low cost and its practicality for 3D printing use.

One of the client's requirements was that the design of the bioreactor system must consider a peristaltic pump that has been previously owned and the purchase of a CO<sub>2</sub> incubator. Also, this project has implemented a control system to aid the peristaltic pump with the flow-rate control and a pH indicator system that will alert the bioreactor operator if the nutritious medium has the correct pH or it needs to be changed. The control system electronic components, the peristaltic pump, and the CO<sub>2</sub> incubator are components that are essential to the operation of the bioreactor system, but they are not designed nor manufactured within this project. These external components and some relevant information about them are presented in the following table.

*Table 8 Not designed required components for bioreactor system operation*

<b>Component Name</b>	<b>Notes</b>	<b>Quantity</b>
Thomas Mini Variable-Speed Peristaltic Pump	Flow-rate range: 85 ml/min	1
CO <sub>2</sub> incubator	Minimum storage dimensions: (WxDxH) 69.1 x 44.4 x 53.3 cm	1
Arduino UNO R3	None	1
Arduino nano	None	1
Water flow sensor YF-S201	None	1
Analog pH sensor - Meter kit	None	1
Light pH indicators	Led lights red and green	2
Servo motor	None	1
LCD	Arduino compatible	1

<b>Component Name</b>	<b>Notes</b>	<b>Quantity</b>
Control system power source	5 Volts battery	2

## DESIGN FOR MANUFACTURING

Manufacturing is the ultimate step of product development for which a methodic plan has to be developed so the workflow can be smooth, and any possible problem encountered may have been anticipated and can have a proper solution. Before reaching the manufacturing process the design of every part has to be done by taking into account the design for manufacturing and assembly guidelines. The following table presents a list of parts that have to be manufactured, its material, and its manufacturing technology or method.

*Table 9 Parts list and manufacturing method*

<b>Part</b>	<b>Material</b>	<b>Part Number</b>	<b>Process of Manufacturing</b>
Bioreactor Sealing Top Cap	Stainless Steel	PB001	CNC Lathe, CNC Mill
Bioreactor Sealing Bottom Cap	Stainless Steel	PB002A1	CNC Lathe, CNC Mill
Scaffold Support Bars	Stainless Steel	PB002A2	CNC Lathe
Scaffold Support Ring	Stainless Steel	PB002A3	CNC Lathe
Bioreactor Chamber	Acrylic	PB003	Injection Mold
Reservoir Cap	Acrylic	PB004A1	Injection Mold
Reservoir	Acrylic	PB004A2	3D Printing

Part	Material	Part Number	Process of Manufacturing
System Tray	Polylactic Acid (PLA)	PB005	3D Printing

To better visualize how the manufacturing process is done for each part listed in Table 9, a series of flow charts have been created. As an example, in the following figure, the manufacture flow chart for the bioreactor sealing top cap (PB001) is shown. The rest of the flow charts for each part can be found in Appendix C

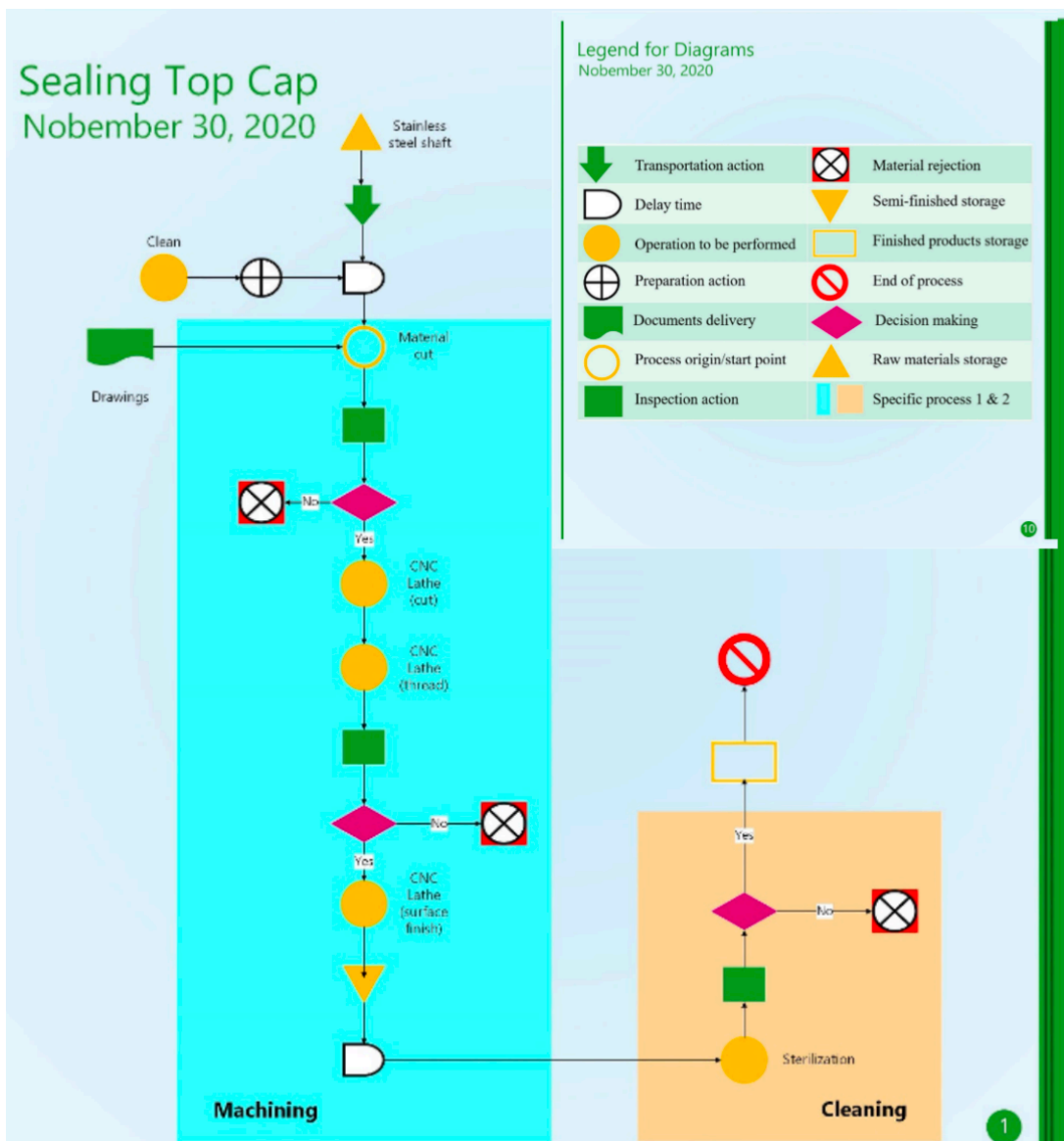

Figure 15 Bioreactor sealing top cap manufacture process flow chart

Using the information from the flow chart regarding the manufacturing process, a manufacturing process sheet is done for each part. This process sheet includes a detailed drawing of the part, manufacturing activities with its description and tentative cost, and performance indicators to control the manufacturing process. For example, a process sheet for the bioreactor sealing top cap is presented in the following figure. For further detail of the process sheets for each part refer to Appendix D.

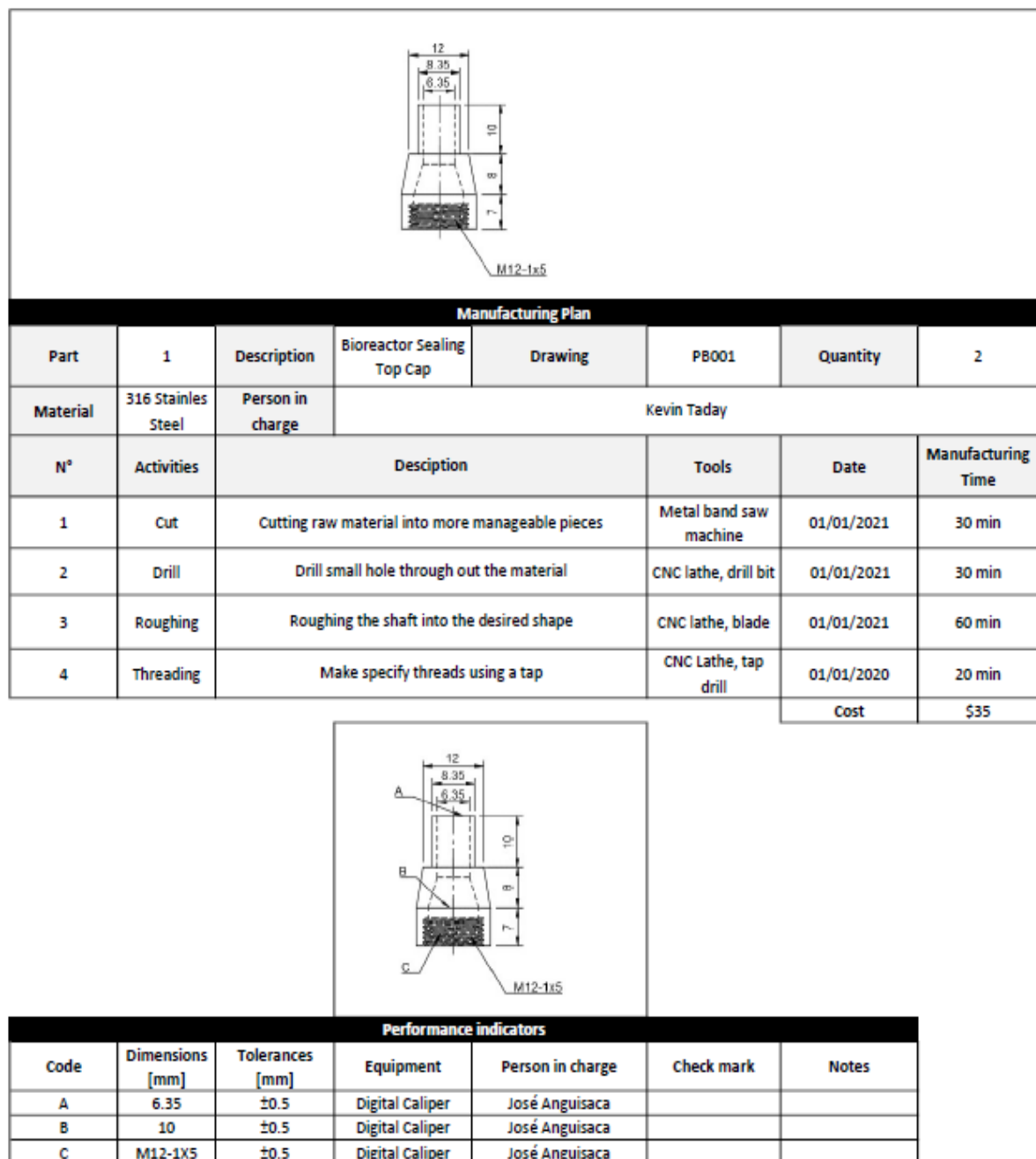

Figure 16 Bioreactor sealing top cap process sheet

Depending on the part the process sheet may also include assembling procedures as well as performance indicators for the assembly.

The bioreactor system designed components have been developed with a long-lasting life in mind with just minor cares, such as cleaning and properly storing. However, other components such as tubing or plastic ball valves must be periodically replaced to ensure the proper performance of the system. This periodically replacing of parts and proper maintenance of the components of the system are detailed in the maintenance and operating manual.

## DESIGN REPORT

The design process needs to be backed up with rigorous calculations and engineering analysis. This project has had four major calculations and analysis fields, which are: fluid dynamics analysis, energy piping system analysis, design of experiments, and control system design. The following table presents what tasks are involved in each field of analysis.

*Table 10 Bioreactor system engineering analysis roadmap*

<b>Fluid dynamics analysis</b>	<b>Energy analysis</b>	<b>Design of experiment</b>	<b>Control system design</b>
Analytical mathematical model selection	Determination of system components, fluid properties, and geometry	Determine phenomena relevant variables and create dimensionless groups	Determine variables to control and how to control them
Analytical model validation with numerical methods (CFD simulation)	Energy analysis based on the system properties to determine its performance	Similitude and scaling analysis	Components selection, circuit layout design, and coding

<b>Fluid dynamics analysis</b>	<b>Energy analysis</b>	<b>Design of experiment</b>	<b>Control system design</b>
Use mathematical analysis to determine geometric properties of the design	Confirm selected system components optimal performance	Model creating and testing	Control system simulation

After developing the analysis mentioned in Table 10, and applying every other considered constraints and client's requirements, a final design prototype for each component has been achieved. The following figure presents the final compact prototype of the designed components of the bioreactor

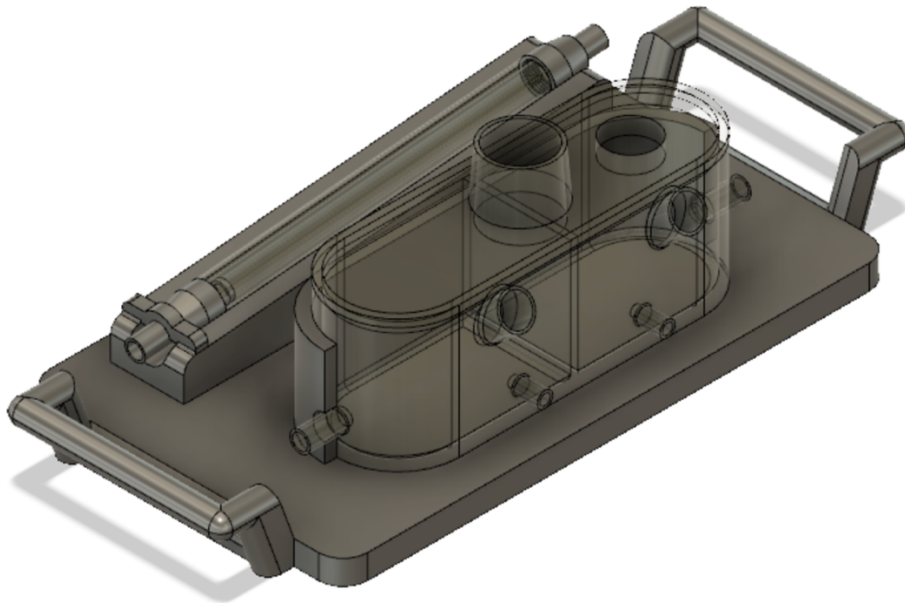

*Figure 17 Bioreactor chamber and reservoir compact distribution prototype*

*Source: Fusion 360*

This prototype as a whole has a maximum length of 25 cm, a maximum height of 7 cm, and a maximum width of 13 cm. For further detail of every designed component of the system refer to the drawings presented in Appendix B.

The following figure presents the final control system prototype layout after going through the engineering analysis.

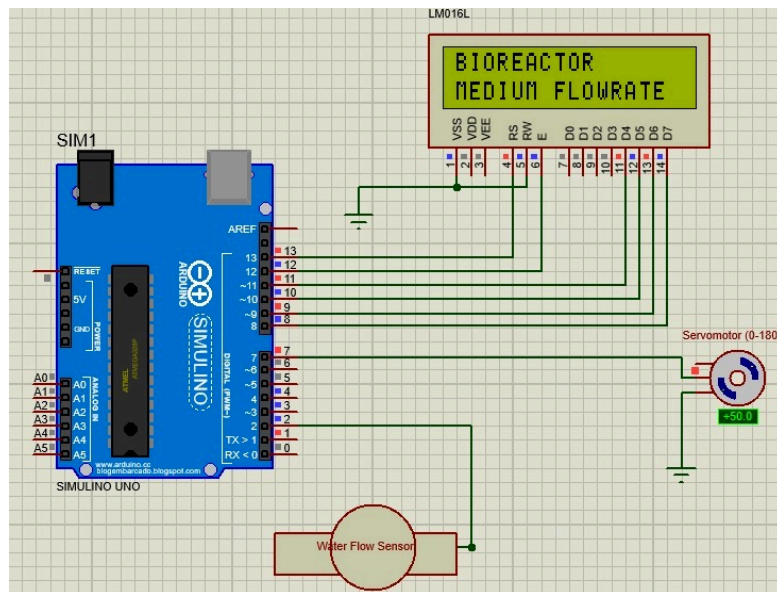

Figure 18 Final prototype control system layout

Source: Proteus

## ENGINEERING ANALYSIS

### Fluid dynamics analysis

There are two main fluid-related requirements that the design of the bioreactor chamber must-have. One is the ability to achieve optimal shear stress over the surfaces of the scaffold and the second is that the flow must be fully developed before reaching the scaffold. To achieve these important requirements some calculations must be performed. First, an analytical analysis will be presented. The results of the analytical analysis will be confirmed with a CFD simulation with a Multiphysics software named COMSOL. The simulation will be set up by using the parameters considered in the analytical calculation process.

The analytical analysis was developed after considering the case of flow past an immerse body. As an analogy one can think of a cylindrical test section inside a wind tunnel. The approach will be to use the known data of the desired flow rate along with the chosen cross-sectional area of the bioreactor chamber to calculate the flow velocity. Once this flow



velocity is calculated it will be used to determine if the shear stress over the surface of the scaffold structural members is within the range that the literature specifies. Then the calculated velocity of the flow will be used to determine the flow regime by using the Reynolds number as a parameter. The flow regime is a key parameter to calculate the entrance length that the bioreactor chamber must have to allow the flow to fully develop before reaching the scaffold.

The optimal shear stress for cell culture is known to be within the physiological range of 0.1 to  $25 \frac{\text{dynes}}{\text{cm}^2}$  or 0.01 to 2.5 Pa (OlufemiE. Kadri, Cortes Williams III, Vassilios Sikavitsas, Roman S. Voronov, 2018). Due to the client's peristaltic pump availability, it is known that the flow rate is between 0.4 to  $85 \frac{\text{ml}}{\text{min}}$ , also the diameter of the bioreactor chamber has been chosen to be 1cm as a result of the client's specification of size optimization constraint. The scaffold consists of circular tubes as structural members with a radius ( $R_s$ ) of  $2.22 \times 10^{-4} \text{ m}$  and uniform porosities with a magnitude of approximately  $5 \times 10^{-4} \text{ m}$ . A close up look of the structural members and porous is presented in the following figure.

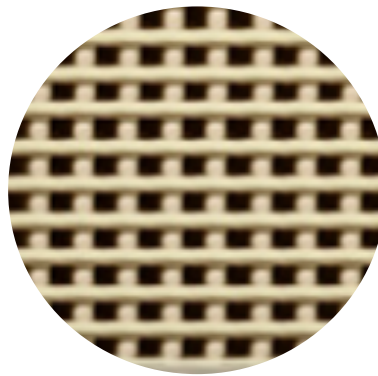

*Figure 19 Close up look at structural members distribution of the scaffold*

*Source: (Xu, et al., 2019)*

The following tables present a summary of the relevant values obtained from literature and relevant known characteristic of the bioreactor chamber and scaffold design.

Table 11 Relevant values obtained from literature and client's specifications

Source: (OlufemiE. Kadri, Cortes Williams III, Vassilios Sikavitsas, Roman S. Voronov, 2018)

Source: EES

<b>Shear stress range</b>	0.01 to 2.5 Pa
<b>Pump flowrate availability range</b>	0.4 to 85 $\frac{ml}{min}$
<b>Water density at 37 Celsius (<math>\rho</math>)</b>	993.36 $\frac{kg}{m^3}$
<b>Water dynamic viscosity at 37 Celsius (<math>\mu</math>)</b>	$6.92 \times 10^{-4}$ s Pa

Table 12 Bioreactor system relevant components dimensions and operating conditions

<b>Scaffold structural members radii (<math>R_s</math>)</b>	$2.22 \times 10^{-4}$ m
<b>Bioreactor chamber diameter (<math>D_B</math>)</b>	0.01 m
<b>System connecting tubes diameter (<math>d_t</math>)</b>	0.00635 m
<b>Optimal operating flow rate (<math>Q</math>)</b>	30 $\frac{ml}{min}$

To calculate the shear stress over the surface of the structural tubes of the scaffold the phenomena can be approached as the case of flow past a cylinder. Knowing the flow rate and diameter of the bioreactor chamber, it is possible to calculate the free stream velocity ( $U_\infty$ ) that the flow will achieve before reaching the scaffold in the bioreactor chamber using the following equation.

$$U_\infty = \frac{Q}{A} \quad (1)$$

Now that the free stream velocity is known the analysis of flow over a cylinder can be used. From experimental studies, the variation of shear stress at the wall over the circumference of a circular cylinder for a laminar boundary layer has been found and it is shown in the following figure.

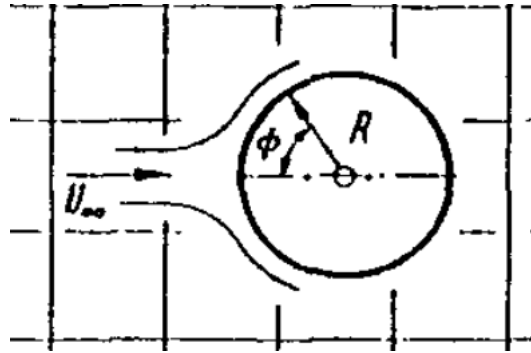

Figure 20 Flow past a cylinder

Source: (Schlichting, 1979)

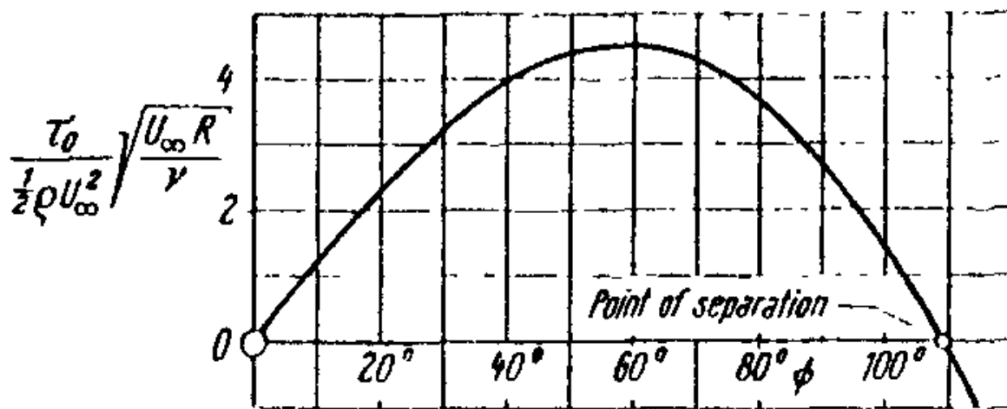

Figure 21 Variation of shearing stress at the wall over the circumference of a circular cylinder

Source: (Schlichting, 1979)

From Figure 21 it can be seen that the maximum shear stress achieved over the surface of a cylinder is at 60 degrees which corresponds to the dimensionless wall shear stress value ( $F(\theta)$ ) of 4.5. The dimensionless wall shear stress equation from Figure 21 can be rearranged and left it in terms of the wall shear stress.

$$\tau_w = \frac{\frac{1}{2} F(\theta) \rho U_\infty^2}{\sqrt{\frac{\rho U_\infty R_s}{\mu}}} \quad (2)$$

Where:  $\tau_w$  is the shear stress,  $\mu$  is the dynamic viscosity and  $\rho$  is the density of the medium. Using Equation 2 along with the previously calculated free stream velocity and the radius of the scaffold structural members, the wall shear stress over the structural members can

be found and checked if the value is within the range of the optimal wall shear stress value for cell culturing that literature specifies.

Once proved that the free stream velocity will provide an optimal wall shear stress has, the next step is to use it to calculate the Reynolds number to determine the flow regime inside the bioreactor chamber before the flow reaches the scaffold. It is important to notice that this Reynolds number uses the bioreactor chamber diameter ( $D_B$ ) as a representative length and can be calculated with the following equation.

$$Re = \frac{\rho U_{\infty} D_B}{\mu} \quad (3)$$

It is known that for a flow in a round pipe it is considered laminar if its Reynolds number is less than 2100 (Munson, Young, & Okiishi, 2016). Once the flow regime and its Reynolds number are known the entrance length ( $l_e$ ) that the bioreactor chamber needs to have for the flow to be fully developed can be calculated with the following equation.

$$\frac{l_e}{D} = 0.06 Re_{laminar\ flow} \quad (4)$$

Now that the analytical analysis has been completed its results can be validated with a numerical solution using a CFD simulation. To set up the CFD simulation in COMSOL some values from the analytical analysis will serve as parameters, such as the entrance length, or the flow free stream velocity. Recalling that the medium has been chosen to be modeled as liquid water and the Reynolds number is low, the physics to be analyzed in the simulation has been chosen to be a single-phase laminar flow. After choosing the physics of the analysis the geometry has to be set up. Due to computational cost, this simulation has been done as a 2-dimensional analysis. The geometry has been set up to represent the bioreactor chamber seen from a side with 10 cylinders located at a distance from the entrance of the chamber that represent the scaffold structural members. The reason to choose 20 cylinders in this model is

to see how the interaction of nearby structural members affects the wall shear stress. This geometry setup is shown in the following figure:

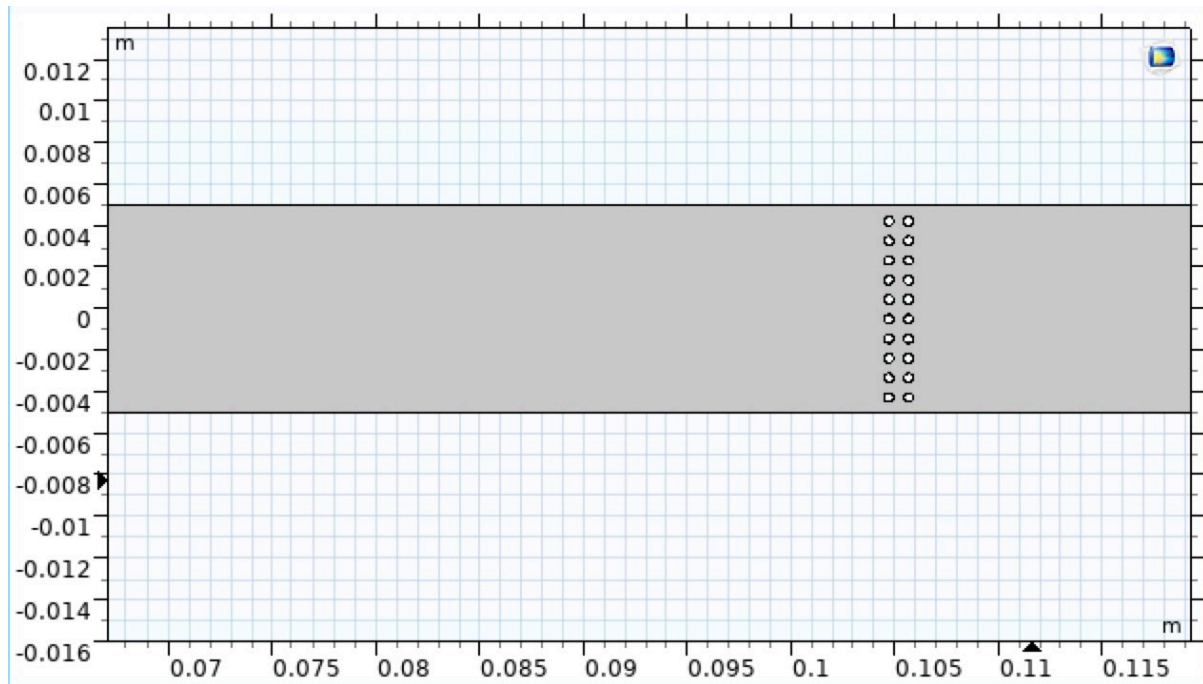

*Figure 22 Geometry of the bioreactor chamber and scaffold structural members sample seen from a side*

*Source: COMSOL*

The diameter of the bioreactor chamber is specified in Table 12 and the length has been chosen based on the entrance length calculated analytically, client's requirements, and safety measures. The radius of the scaffold structural members is specified in Table 12.

After setting up the geometry, the velocity variable had to be specified. The value for the free stream velocity established for the simulation is the one calculated analytically. Then the material of the medium has to be added to the geometry domain. As mentioned before the medium is modeled as liquid water. After adding the material, the boundary conditions were established. The left side of the bioreactor chamber has been set up as the inlet with a normal inflow velocity equal to the free stream velocity as a boundary condition. The right side of the chamber was set up as the outlet with a pressure boundary condition equal to 0. The upper

and lower walls were set up as not moving walls equipped with the no-slip condition to see how the flow develops inside the channel.

Once the boundary conditions have been established a meshed was applied to the geometry domain. For the mesh, it was chosen an extra-fine physics-controlled mesh that resulted in 1448072 domain elements, 65290 boundary elements, and 3074 edge elements. The meshed geometry is shown in the following figure.

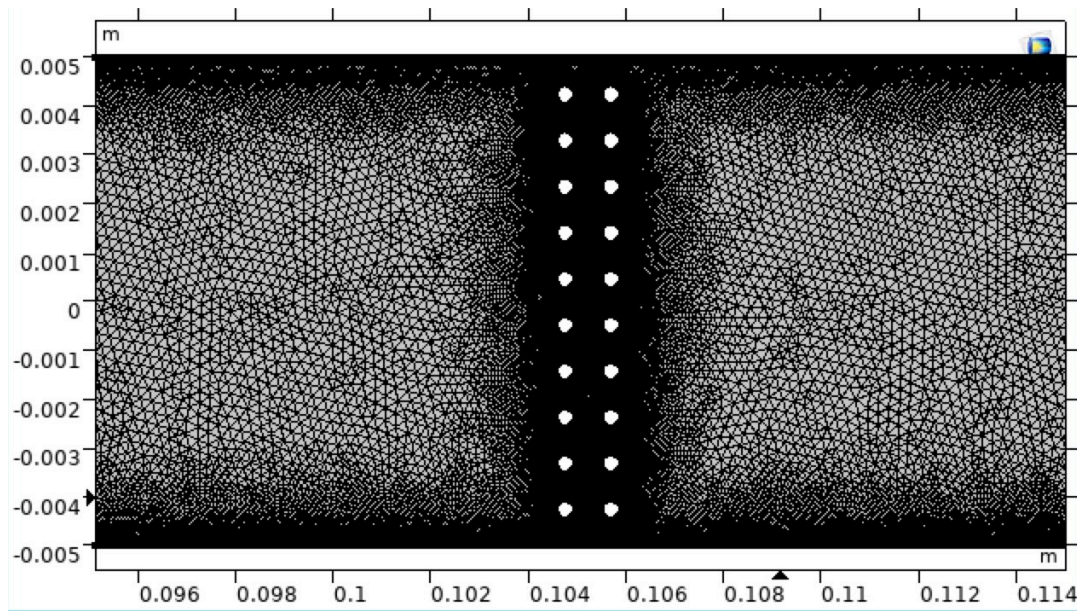

*Figure 23 Portion of the geometry applied an extra-fine physics-controlled mesh*

*Source: COMSOL*

After meshing the geometry, a stationary study was add and then the simulation was run and the results will have to be computed at the post-processing stage.

For further validation of the analytical analysis, a three-dimensional simulation was performed. For this simulation, the physics as well as the boundary conditions and flow parameters are the same as in the two-dimensional simulation. What is changed in this simulation setup is the geometry and the post-processing of the results. The mesh of the geometry was again a physics-controlled mesh with a fine element size which resulted in

1437480 domain elements, 66756 boundary elements, and 3139 edge elements. The following figures show the geometry set up for further clarification.

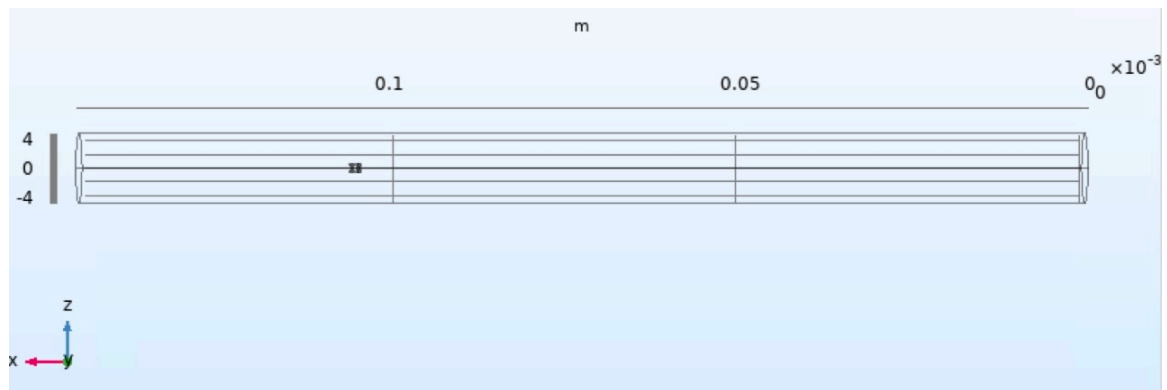

Figure 24 Geometry of the bioreactor chamber and scaffold structural members three-dimensional simulation

Source: COMSOL

The results for the analytical analysis and both simulations are presented in the results and discussion section.

### Energy analysis for system's pressure drop

To calculate the pressure drop in the bioreactor system is crucial to consider all the events that take place during the process. The first critical section in the system that needs to be analyzed is the pressure drop in the flowing fluid through the scaffold. To make this calculation, it was necessary to use the Kozeny-Darcy equation (Bernsdorf et al., 2000). This equation provides an analytical solution for the pressure drop of a fluid that goes through a porous solid. The flow is modeled as a flow-through a bundle of channels with no strongly changing cross-sections. This solution gives a relationship between the mean flow velocity ( $\bar{U}_x$ ), and the pressure drop ( $dP$ ) as shown below.

$$\bar{U}_x = -\frac{1}{2\mu} \left( \frac{dP}{dx} \right) R_h^2 \quad (5)$$

Where  $\mu$  is the fluid viscosity,  $x$  is the mean flow coordinate, and  $R_h$  is the hydraulic radius, which is the ratio of fluid volume and wetted surface. The hydraulic radius is calculated with the following equation:

$$R_h = \frac{\pi R_s^2}{2\pi R_s} = \frac{R_s}{2} \quad (6)$$

Where  $R_s$  is the radius of the scaffold structural members. Since the scaffold design has tubes with a regular shape Equation 5 can be rewritten as:

$$\widetilde{U}_x = -\frac{1}{2\mu} \left( \frac{\Delta P_{chamber \ bioreactor}}{\Delta L_s} \right) \widetilde{R}_h^2 \quad (7)$$

Where the mean hydraulic radius,  $\widetilde{R}_h$ , is the average of the structural members of the scaffold,  $L_s$  is the length of the porous solid and as an approach, it was established as 0.03 meters. Since the velocity  $U_x$  is a known parameter it is possible to calculate the pressure drop through the bioreactor chamber.

The second crucial section to be analyzed is the pressure loss through the plastic tube that connects all the components. The system counts with frictional losses, that depend on the length of the plastic tube, and minor losses, due to accessories that change the flow along the system. In this analysis is important to establish 2 specific locations, these locations are references where the fluid will be moving from location 1 to location 2. The reference points are shown in the following figure:



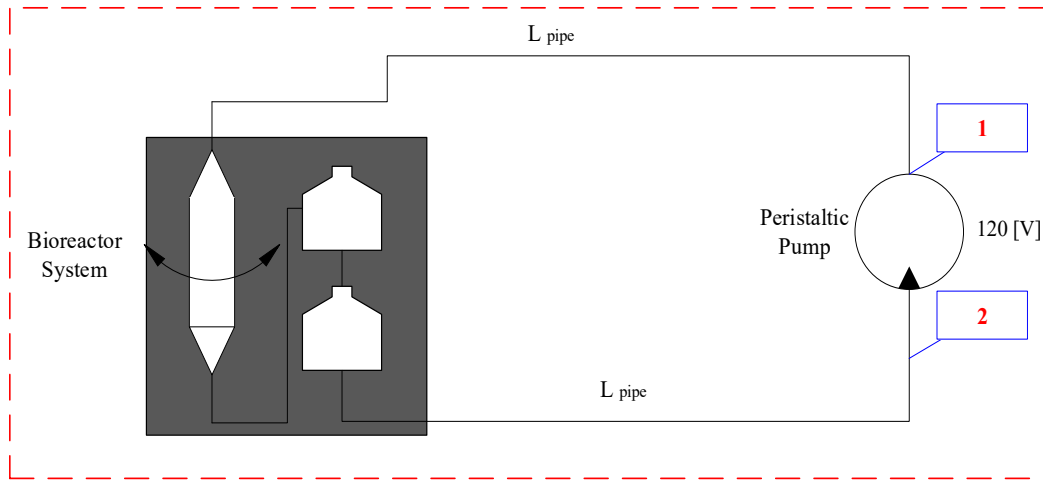

Figure 25 Simplified Bioreactor system to be analyzed

For this analysis, the energy equation or Bernoulli equation is used and it is described as follows.

$$\frac{P_1}{\rho g} + \frac{V_1^2}{2g} + z_1 = \frac{P_2}{\rho g} + \frac{V_2^2}{2g} + z_2 + \frac{fL_t V^2}{D_h 2g} + \sum K \frac{V^2}{2g} \quad (8)$$

Since there is no change in potential energy,  $z_1 = z_2$ , and the velocity is the same since the flow is constant through the whole system, thus  $V_1 = V_2$ . Therefore, the previous equation can be rewritten.

$$\frac{P_1}{\rho g} = \frac{P_2}{\rho g} + \frac{fL_t V^2}{D_h 2g} + \sum K \frac{V^2}{2g} \quad (9)$$

To calculate the total pressure drop in the system it is necessary to add the pressure loss due to the porous media of the scaffold and add it to the Bernoulli equation as it follows.

$$\frac{P_1}{\rho g} = \frac{P_2}{\rho g} + \frac{fL_t V^2}{D_h 2g} + \sum K \frac{V^2}{2g} + \frac{\Delta P_{chamber\ bioreactor}}{\rho g} \quad (10)$$

In this past equation since the system is working with a laminar flow, the friction factor  $f$  is taken as  $\frac{64}{Re}$ , the velocity  $V$  in major and minor losses can be interpreted as the free stream velocity  $U_\infty$  inside the tubes.  $L_t$  is the total length of the plastic tube, which has been considered to be the maximum length that the system may present, which is 1.5 meters. This length value

has been determined by consulting with the client. Also, there are components in the system that create minor losses such as 1 sudden enlargement, 1 contraction, 3 tube entrances, 3 tube exits, and one ball valve connecting the reservoir. All these resistance coefficients,  $K$ , for minor losses are stipulated in the book of Thermal Energy Systems of Steven G. Penoncello.

The results were computed using the software EES and summarized in the results and discussion section, the code for this analysis is presented in Appendix E.

### Design of experiments

Experimentation is a key component of any project development. However, any experiment has to be carefully designed so results can be consistent and representative. To begin with the design of the experiment of this project, the variables used in the analytical analysis are examined to determine their relevance and how they are related to each other. From the analytical analysis, it is seen that the wall shear stress ( $\tau_w$ ), the diameter of the scaffold structural members ( $d_s$ ), the diameter of the bioreactor chamber ( $D_B$ ), the medium density ( $\rho$ ), viscosity ( $\mu$ ), and velocity ( $V$ ) are relevant variables for the analysis and they are related to each other as follows.

$$\tau_w = f(d_s, D_B, \rho, \mu, V) \quad (11)$$

Once determined the relevant variables and their relationship. The analysis to be applied is called Buckingham Pi Theorem. This theorem allows to reduce the number of variables by creating dimensionless groups which will further down will be used to design the experiment using a similitude method. The next step is to express the initial variables in their basic dimensions as follows.

$$\tau_w = \frac{M}{L T^2} \quad (12)$$

$$d_s = L \quad (13)$$

$$D_B = L \quad (14)$$

$$\rho = \frac{M}{L^3} \quad (15)$$

$$\mu = \frac{M}{L T} \quad (16)$$

$$V = \frac{L}{T} \quad (17)$$

From the above equations, it can be seen that the reference dimensions are mass (M), length (L), and time (T). Therefore, there are 3 reference dimensions (r=3), plus there are 6 initial variables (k=6). To determine the number of possible dimensionless Pi groups that can be obtained, the number of reference dimensions is subtracted from the number of initial variables (k-r = 3). Therefore, the analysis will return 3 Pi dimensionless groups. Knowing there will be 3 Pi groups 3 initial variables are chosen to be the repeating variables, which in this case are:  $\rho$ ,  $d_s$ , and  $V$ . Using these repeating variables, the Pi groups are formed by multiplying one of the nonrepeating variables by the product of the repeating variables, each raised to an exponent that will make the combination dimensionless. For example, for the wall shear stress variable, this process looks like the following equation.

$$\left(\frac{M}{L T^2}\right) \left(\frac{M}{L^3}\right)^a (L)^b \left(\frac{L}{T}\right)^c = M^0 L^0 T^0 \quad (18)$$

The same process shown in Equation 18 is done for the rest of the not repeating variables and they have been solved to return the following Pi terms.

$$\Pi_1 = \frac{\tau_w}{\rho V^2} \quad (19)$$

$$\Pi_2 = \frac{D_B}{d_s} \quad (20)$$

$$\Pi_3 = \frac{\mu}{\rho dV} \quad (21)$$

It can be seen that these Pi terms are well known dimensionless groups. For example, the first Pi term is known as the Friction coefficient, the second Pi term is known as the Length

ratio, and the third Pi term is the Reynolds number. Furthermore, this Pi terms give the variable relationship as it follows.

$$\frac{\tau_w}{\frac{1}{2}\rho V^2} = \phi\left(\frac{D_B}{d_s}, \frac{\mu}{\rho dV}\right) \quad (22)$$

Now using these new variables relationship, the goal is to design a model that can be used to predict the wall shear stress on the prototype. To do this model design conditions or similarity requirements are found by equating the non-dependable variables of the relationship between the model and the prototype. This process is done to scale the model to a more possible laboratory condition. To identify the model variables, they will have an “m” subscript to them. The similitude process is described as follows.

$$D_{Bm} = \frac{d_{sm}}{d_s} D_B \quad (23)$$

$$V_m = \left(\frac{\mu_m \rho d_s}{\mu \rho_m d_{sm}}\right) V \quad (24)$$

Equation 23 allows to set an arbitrary ratio between the diameter scaffold support members and then multiply them by the prototype bioreactor diameter to obtain an actual well-defined diameter for the bioreactor model. Therefore, this equation allows the model to be scaled to a more manageable dimension. Aside from the geometry of this model, the experiment also needs control over the flow properties, which is the purpose of Equation 24. This equation sets a well-adjusted free stream velocity for the model.

As mentioned before this analysis has to be done to create an experimental model that can be used to either predict or confirmed the analyzed phenomena in the prototype.

### **Control system design**

To automate the bioreactor system, it was necessary to focus on two specific and critical areas of the system, these areas are: control the medium flowrate from the peristaltic

pump and pH control of the medium in the reservoir. The two areas are located in points 1 and 2 as shown in the following figure.

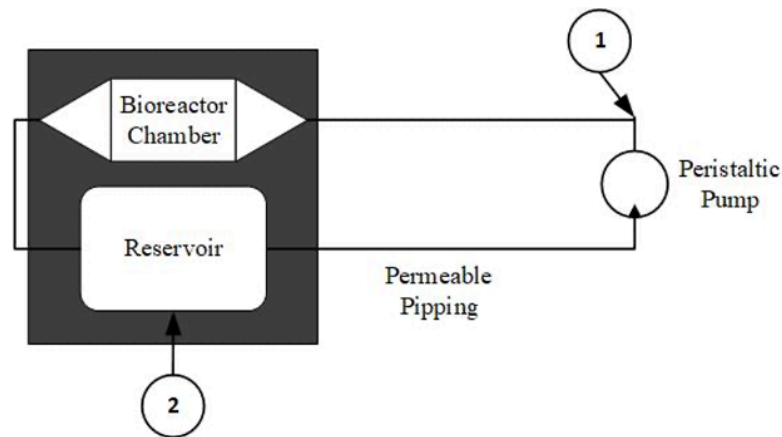

*Figure 26 Control diagram of the bioreactor system*

Area number 1 shown in the previous figure is the control of the medium flowrate given by the peristaltic pump, this is a critical area because even though the peristaltic pump is a very precise equipment and has a built-in flow control that has a small range of error sometimes the value may vary. To prevent any misreading from the peristaltic pump built-in flow control, it was necessary to implement an electronic system with a microcontroller to be constantly adjusting the medium flow to the desired value if necessary. This electronic system will work as a redundant control system for the peristaltic pump and also it will be a backup system to control the medium flow through the pump.

The components to be used in this first control are:

- Arduino Uno
- LCD (LM016L)
- Servo Motor (0 -180)
- YF-S201 Hall-Effect Water Flow Sensor

These components were selected based on the peristaltic pump that is used in the system; the peristaltic pump has a knob that regulates the flowrate that is being sent as shown in the following figure.



*Figure 27 Bioreactor system peristaltic pump*

*Source: (Thomas Scientific, n.d.)*

The knob in the peristaltic pump controls the flow rate of the fluid. As explained before the peristaltic pump is precise equipment but sometimes is better to have a backup system to prevent unwanted results, to make this backup electronic system a servomotor is going to be attached to the knob, this servomotor is a device that has an angle range from 0 to 180 degrees and is going to act with a signal that the YF-S201 Hall-Effect Water Flow Sensor will give, according to the signal from the water flow sensor the servomotor is going to be programmed such as if the medium flowrate decreases the servomotor is going to rotate clockwise or if the medium flowrate increases it will rotate counterclockwise until it reaches the specific value of flowrate that in this case according to the customer specifications will be 30ml/min.

The signal of the electronic system will be given from the YF-S201 Hall-Effect Water Flow Sensor, this sensor contains a pinwheel sensor to measure how much water has moved through it, there is an integrated magnetic Hall-effect sensor that outputs an electrical pulse with every revolution, this means that depending on how much water goes through the wheel

the frequency pulse will be higher or lower, the water flow sensor is shown in the following figure.

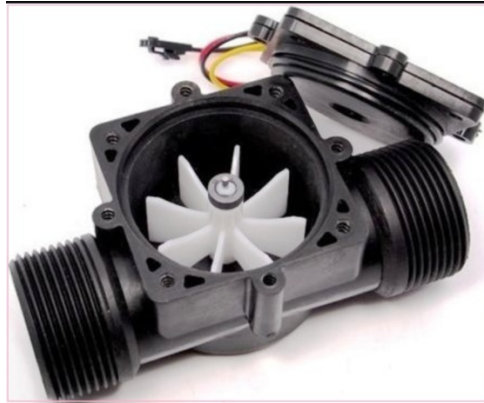

*Figure 28 YF-S201 Hall-Effect Water Flow Sensor*

*Source: (T.K. Hareendran, n.d.)*

From the flow sensor datasheet (Mechatronics, n.d.), it is known that the flow is measured using the following equation.

$$Q \left( \frac{L}{\text{min}} \right) = \frac{\text{Pulse sensor frequency (HZ)}}{7.5} \quad (25)$$

The sensor receives the frequency of the pulses and with the equation above the frequency is transformed to liters per minute, with this equation the microcontroller can receive a flow value and send that information to the servomotor to regulate the peristaltic pump knob.

The microcontroller in this system will be an ARDUINO UNO, this microcontroller is going to make sure that the flowrate value is constantly checked to adjust the pump knob with the servomotor, the ARDUINO CODE will be presented and explained in Appendix E.

Finally, to present the flowrate values there will be an LCD (LM016L) screen that will show the operator the flowrate that the water flow sensor is detecting. A fully electronic assembly of the first control system is shown in the following figure.

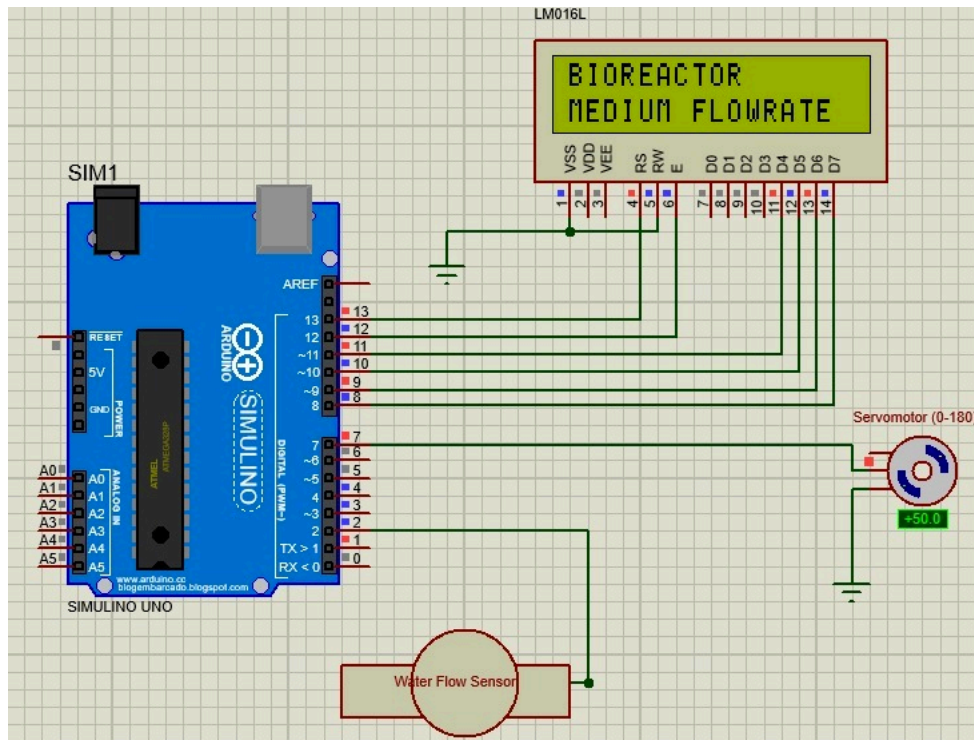

Figure 29 Flowrate control system components connection layout

Source: Proteus

The second controlled area shown in the Figure 26 is the pH sensor attached to the reservoir, according to customer specifications this is also an important area to be controlled because if there is a change in the medium pH it could ruin the whole procedure of cell growth, the cells must be in a medium flow with a specific pH, that is why it is important to keep track of the pH in the medium, the pH sensor was implemented in the reservoir because it was the best position to put a sensor with such dimensions.

The components to be used in this second control are:

- Arduino Mini
- pH sensor
- 220ohm Resistors
- Green and Red LED

The pH sensor is a device that works as a voltmeter and this works because for example, an acidic substance has more positively charged hydrogen ions than an alkaline



substance, so it produces a greater electrical current, the pH sensor measures the voltage produced by the substance and it compares it with the voltage of a known substance, the difference in voltage between the two substances is used to deduce the difference in pH. In the following figure, there is a chart where there are different substances with their pH range.

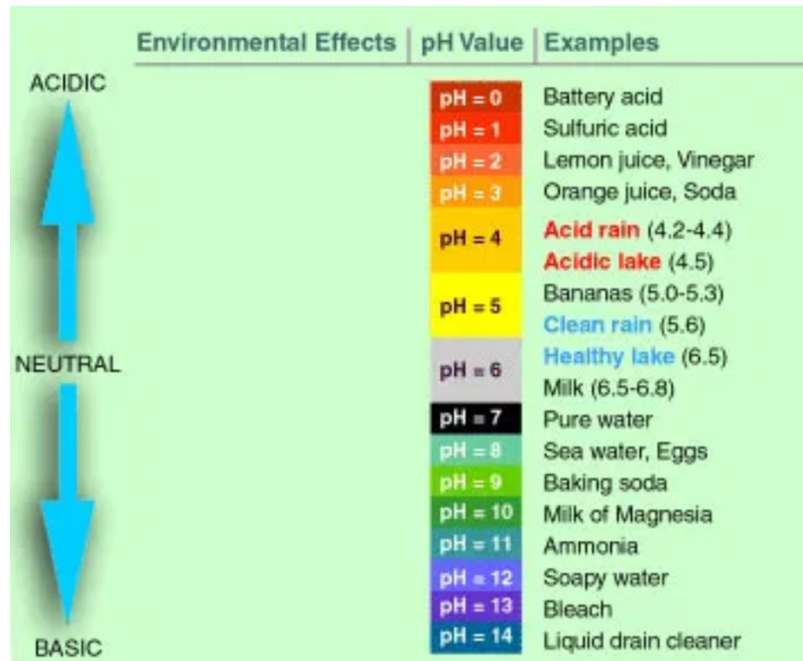

Figure 30 Different substances pH range

Source: (Fahad, 2019)

The pH sensor comes with an interface circuit with a BCN connector shown in the following figure:



Figure 31 Analog pH sensor - Meter kit

Source: (Store, Arduino, n.d.)

The work that the pH sensor does with the programming takes 10 sample values and store these values in an array, after that we implement two for loops to sort the values from small to large in an ascending order, then it converts the value into millivolts, and after that into the pH value. Finally, the pH value is stored in a variable that if it doesn't meet the condition of the specific pH value will turn the RED LED on and if it meets the condition the GREEN LED will turn on. the ARDUINO CODE will be presented and explained in more detail in Appendix E. A fully electronic assembly of the second control system is shown in the following figure:

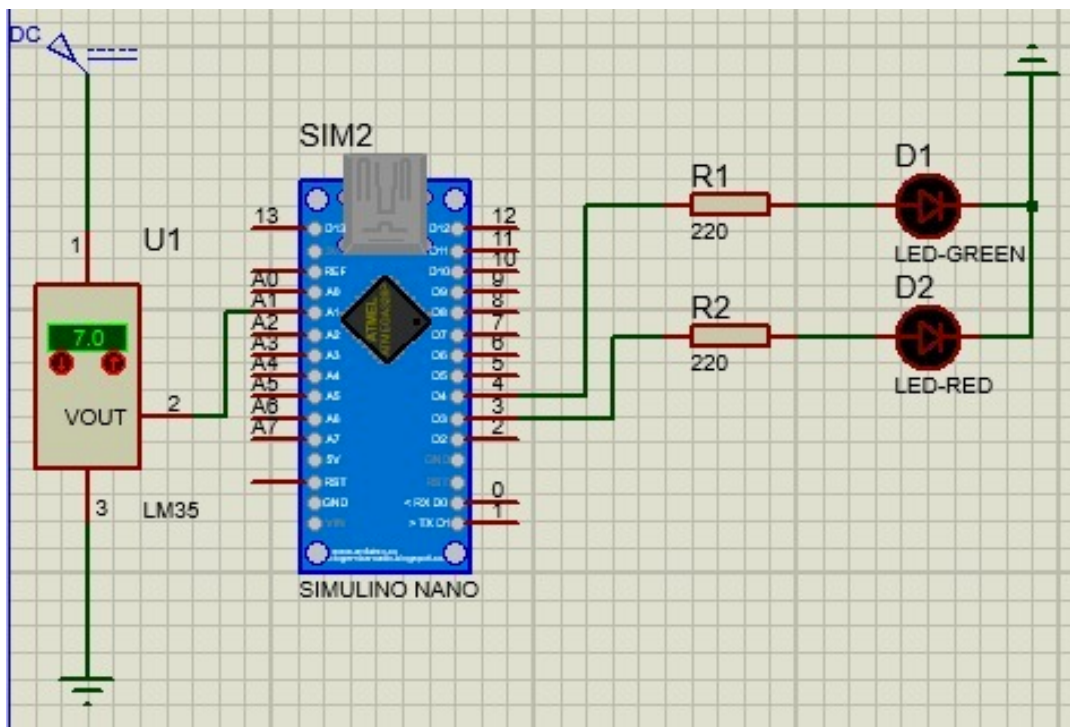

Figure 32 pH control system circuit connection layout

Source: Proteus

The simulation for the two electronic systems were made in the software PROTEUS, which is a software to simulate electronic components with microcontrollers such as Arduino UNO and Arduino mini. First is necessary to download all the components library in the PROTEUS software specific the Arduino library.

For the first electronic system, it is necessary to select the exact electronic devices or similar ones, as mentioned before the electronic components are: Arduino UNO, LCD (LM016L), Servo Motor (0 -180), YF-S201 Hall-Effect Water Flow Sensor. In this case, PROTEUS does not count with a hall effect water flow sensor so to simulate this process it is necessary to put a pulse generator that will give a signal to the microcontroller Arduino UNO through pin 2, as shown in the following figure the pulse generator controls the different frequencies that the user want to create:

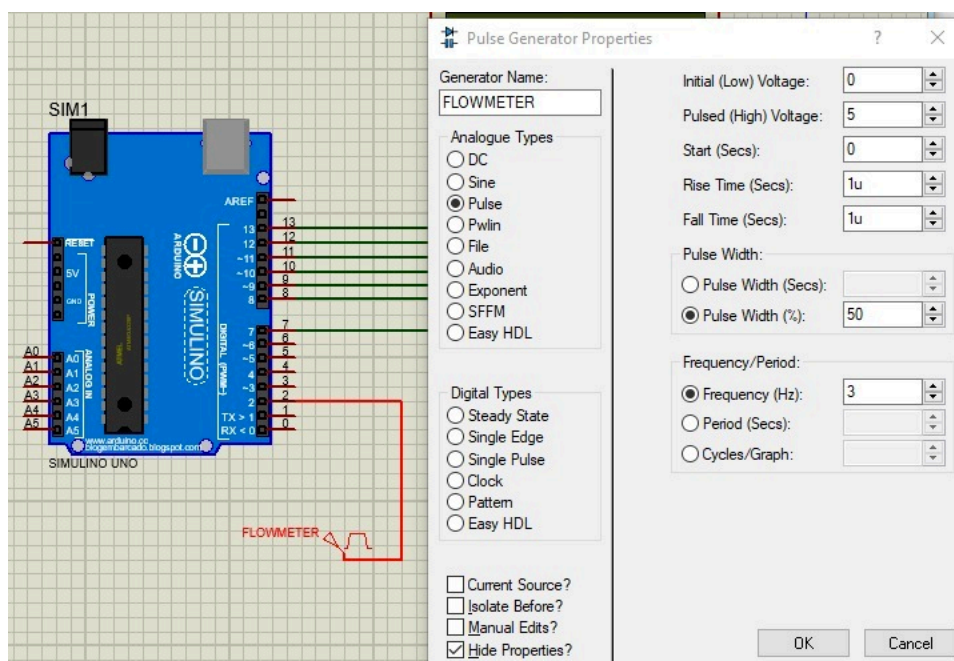

Figure 33 Pulse generator setup for flowrate control simulation

Source: Proteus

To test if the pulse generator is generating the correct pulse and oscilloscope was connected to control the pulses sent to the microcontroller, in the following figure there is an example of a pulses with a frequency of 3 Hz.

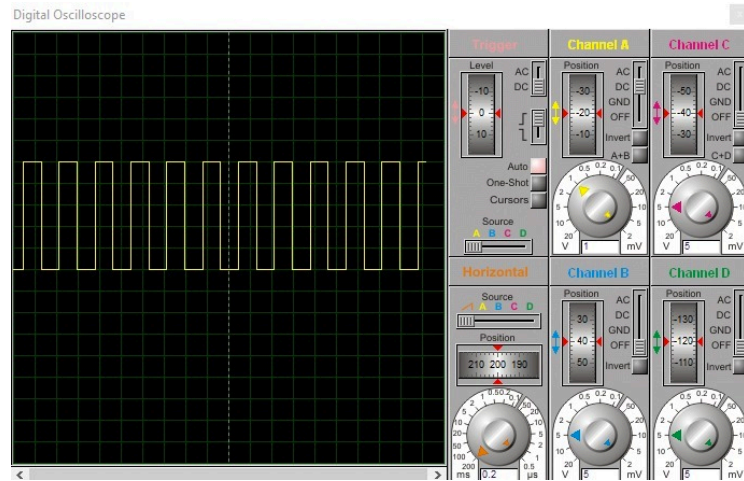

Figure 34 Proteus oscilloscope sample reading of a pulse

Source: Proteus

The servomotor as well as the pulse generator need to be set up for the microcontroller to send the correct instruction, to set up the servomotor it was necessary to put it in a range of 0 to 180 degrees and a minimum control pulse of 544u (micro-Hz) to 2400u, these values are common values that most servomotors work with. In the following figure there is the set up for the servomotor:

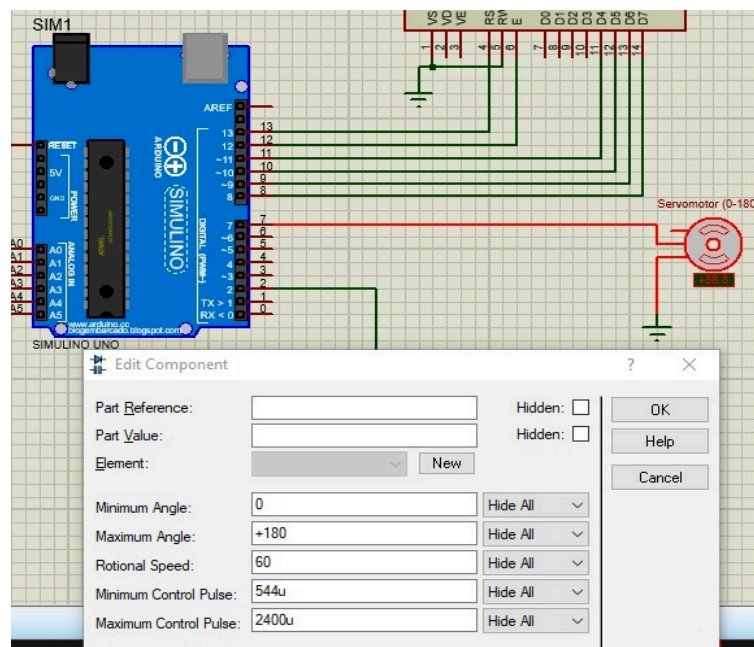

Figure 35 Servomotor simulation setup

Source: Proteus

There is an issue with the pulse generator which is that it cannot read decimal values so to simulate the real values that the peristaltic pump will provide it was necessary to apply in the code some time sentences that will change the flow frequency while the time is running, this part of the code is represented in the following figure.

```

void loop ()
{
    currentTime = millis();

    ////////////////Use for Proteus Simulation
    if(currentTime-zeroTime<=2000){
        flow_frequency=0.003;
    }
    else if (currentTime-zeroTime<=6000){
        flow_frequency=0.6375;
    }

    else if (currentTime-zeroTime<=7000){
        flow_frequency=0.4;
    }

    else if (currentTime-zeroTime<=9000){
        flow_frequency=0.225;
    }

    else {
        zeroTime=millis();
        //currentTime = millis();
    }
    ////////////////Range of values of flow_frequen

```

*Figure 36 Code section added to solve flow frequency in simulation*

This part of the Arduino UNO code controls the frequency signal that will be sent to the microcontroller at different times. The first flow frequency is 0.003 Hz until the timer gets to 2 seconds, the next flow frequency is 0.6375 Hz until the timer gets to 6 seconds, the next flow frequency is 0.4 Hz until the timer gets to 7 seconds, and finally, the flow frequency is 0.225 Hz until the timer gets to 9 seconds. When the timer gets over 9 seconds the timer will restart.

For those different cases of time simulations, the servo will move to each position, and depending if the flowrate is below or above the limit which is 30 ml/min it will turn clockwise or counterclockwise, or if the value is at the limit it will stay at the same position.

- Time Case 1:

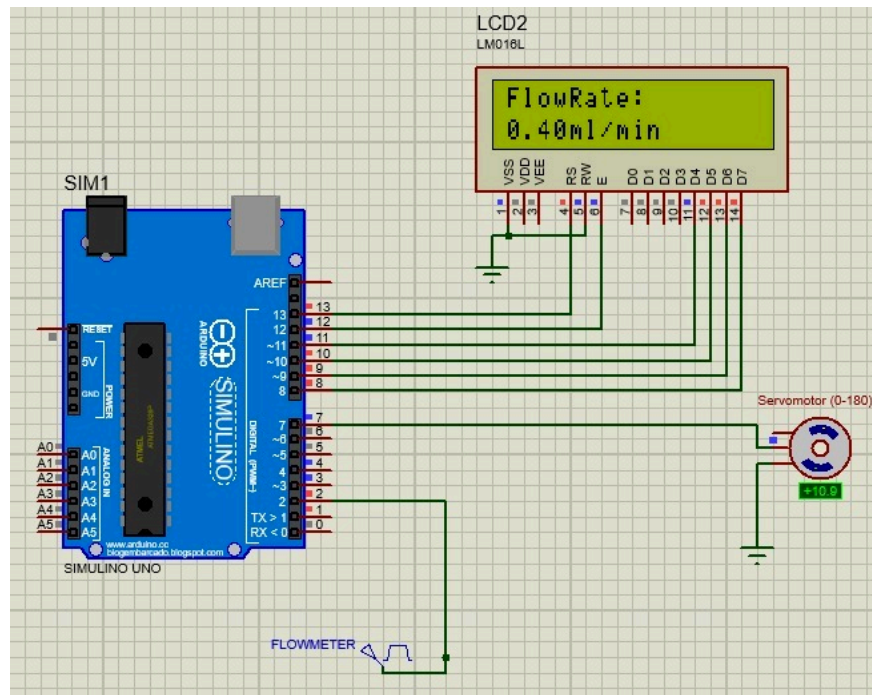

Figure 37 First time case simulation for the flow control system

Source: Proteus

- Time Case 2:



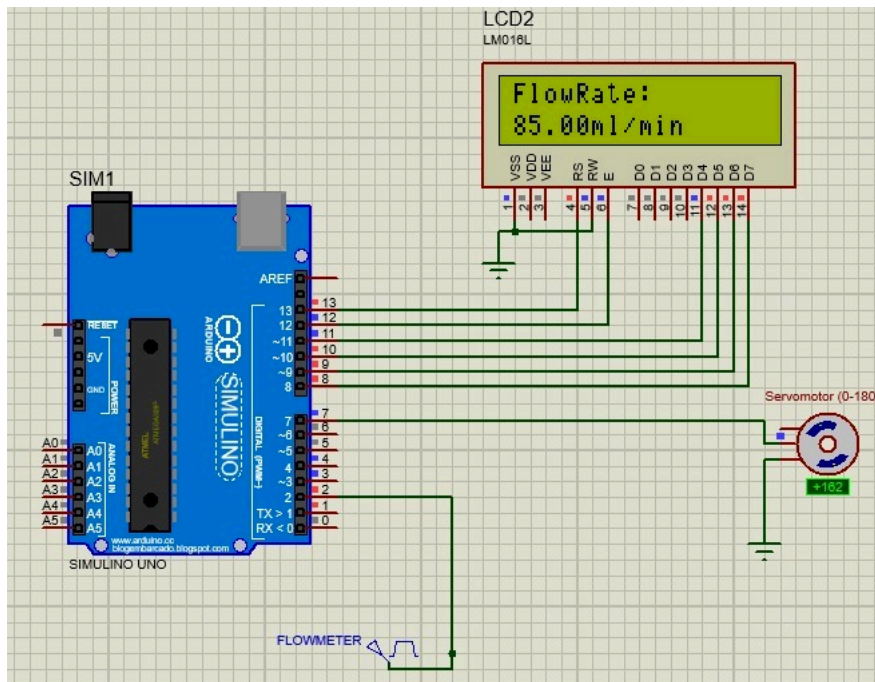

Figure 38 Second time case simulation for the flow control system

Source: Proteus

- Time case 3:

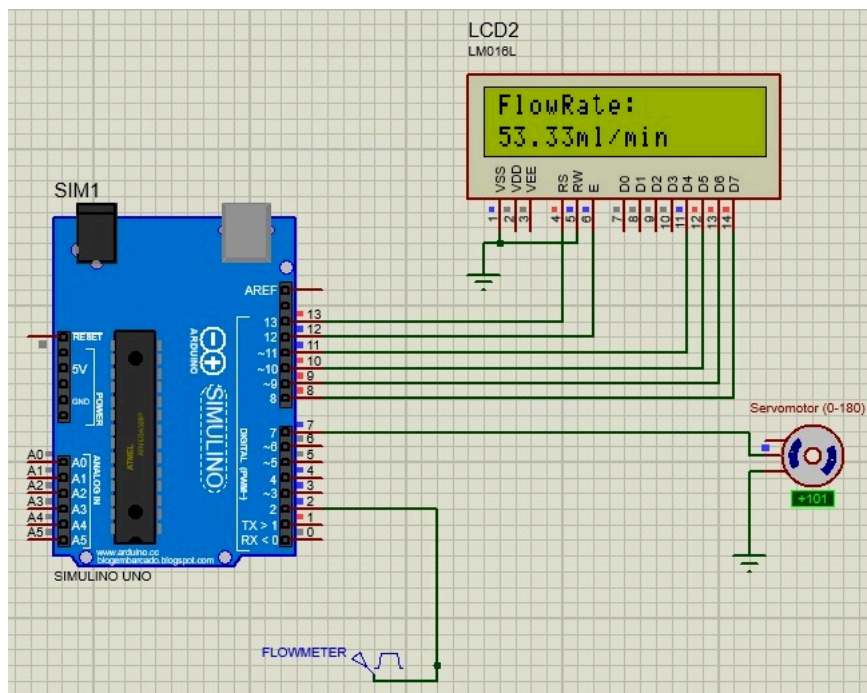

Figure 39 Third time case simulation for the flow control system

Source: Proteus

- Time case 4:

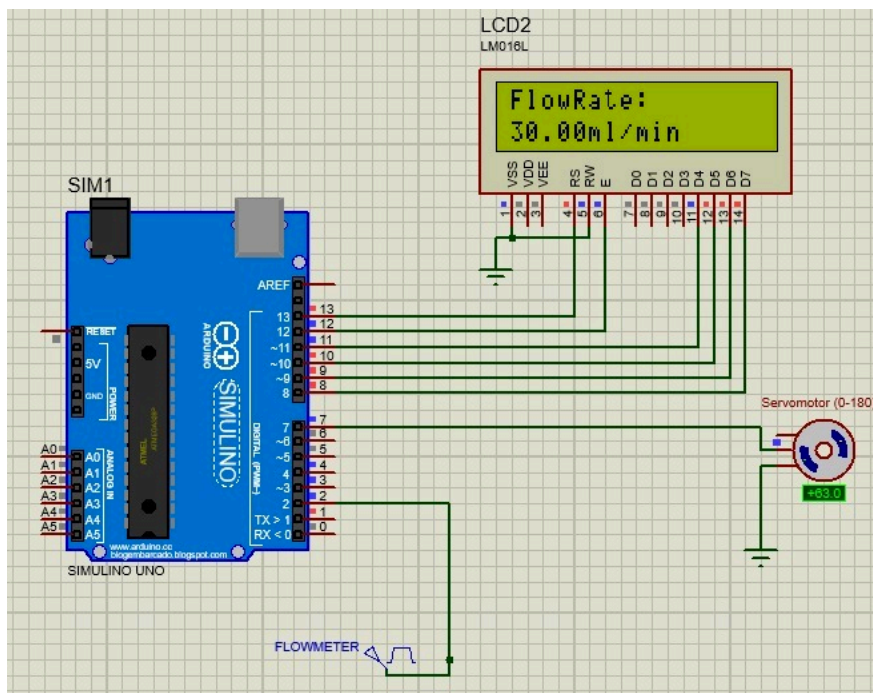

Figure 40 Fourth time case simulation for the flow control system

Source: Proteus

Nevertheless, a simulation test was realized with the pulse generator assuming that the frequencies values are integers, in this case, we put a low frequency of 2 Hz:

- Pulse Generator Case:



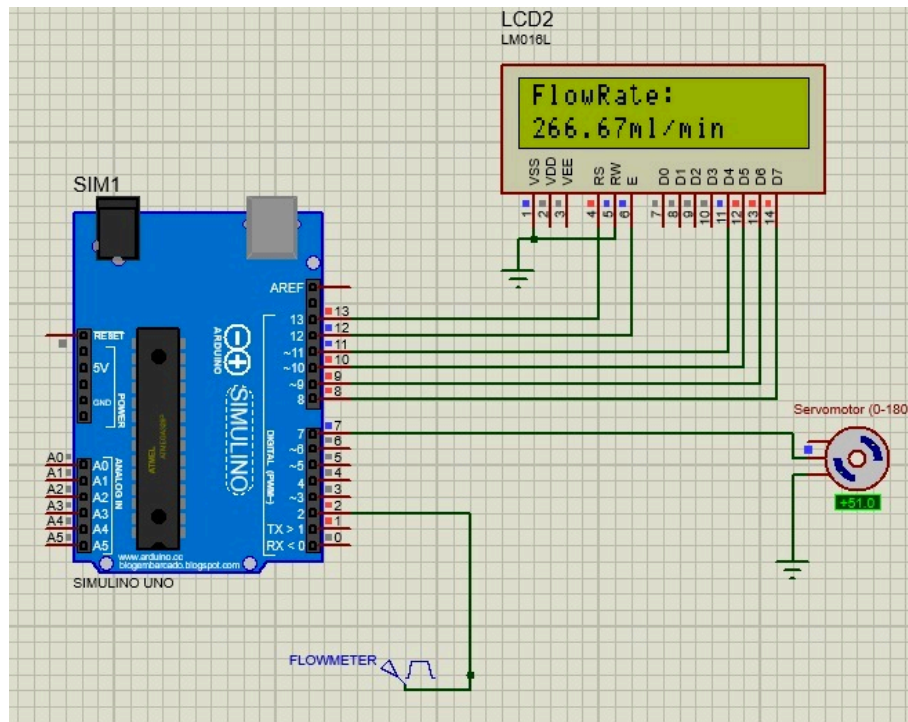

Figure 41 Pulse generator case simulation for the flow control system

Source: Proteus

For further clarification and to visualize a full simulation, refer to the following YouTube Link: <https://youtu.be/T9Eurt6Bu1M>

For the second electronic system, the components are: Arduino Mini, pH sensor, Resistors of 220 ohm, Green and Red LED. In this case, such as the last one PROTEUS does not count with a pH sensor, so to simulate this process it is necessary to put a temperature sensor that will provide an analog signal to the pin A1 that the microcontroller will interpret, depending on the value, if the signal is in the correct pH range turn on the GREEN LED otherwise if the pH signal is lower or higher than the pH specified range the RED LED will turn on. The only set up in this electronic system is the input of a direct current (DC) of 5V connected to the pH sensor. In the following figure there is represented the second electronic system set up:

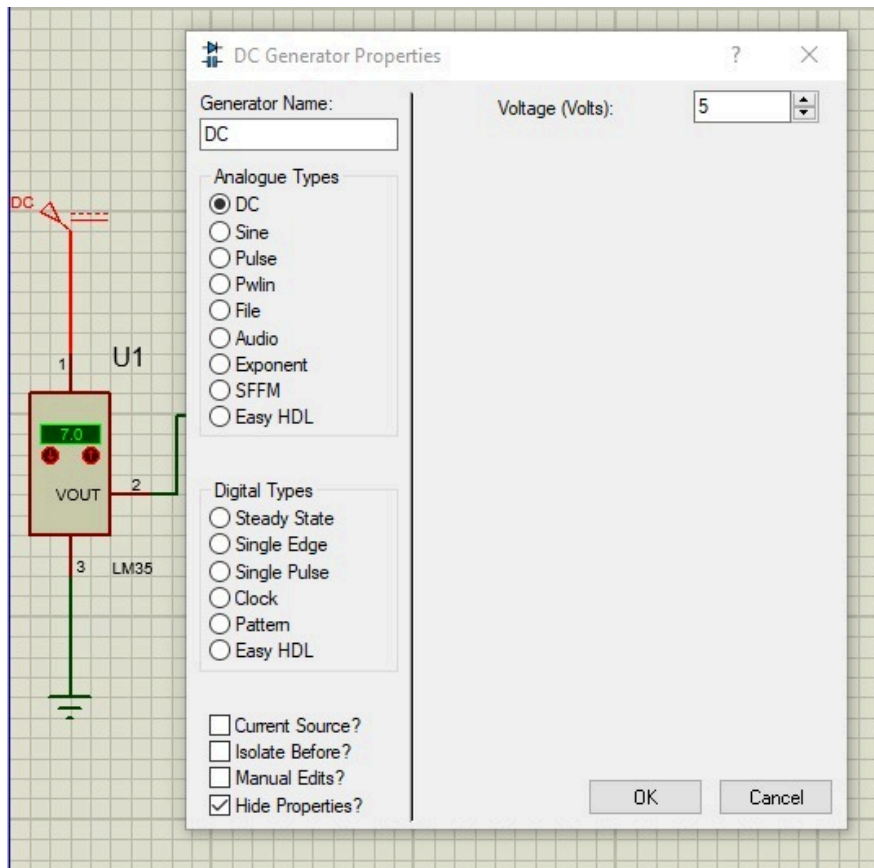

Figure 42 DC generator setup for pH control system simulation

Source: Proteus

In this simulation, there are two cases which are: the first one is when the pH is in the correct range of values the operator will see that the GREEN LED is on which means that there is no pH variation in the medium and is safe to continue with the process. The second case is when the pH value is lower or higher than the established one the RED LED will turn on telling the operator to stop the process and change the medium.

- Case 1

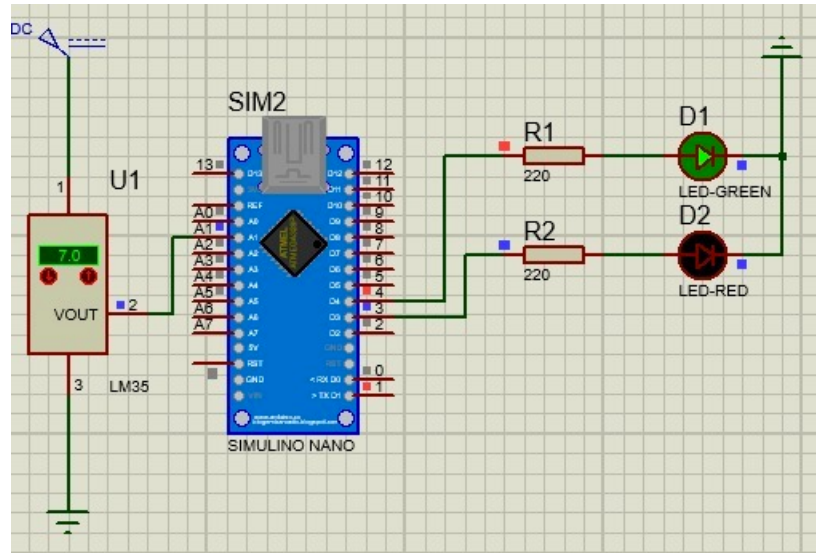

Figure 43 First case simulation for the pH control system

Source: Proteus

- Case 2





*Table 13 Prototype test plan guidelines*

<b>Test</b>	<b>Validation method</b>
Measure bioreactor tray & components dimensions	Measure less than (WxDxH) 69.1 x 44.4 x 53.3 cm
Weight bioreactor tray & components	Weight less than 1.5 kg
Measure wall shear stress	Craft an experiment and use similitude parameters to test results
Measure flow rate	Use an alternative method to measure flowrate and check control system readings
Measure pH	Use an alternative method to measure pH and check control system readings

### **Geometric/physical prototype test**

As one of the requirements for the development of this prototype was the size and transportability of the system, the validation method is that the dimensions of the bioreactor tray assembly with all of its components must be less than the expected incubator storing dimensions which are (WxDxH) 69.1 x 44.4 x 53.3 cm. Also, to check the transportability of the prototype the validation method will be to measure the weight of the bioreactor tray with all its components. To assure comfortable transportability the tray with all its components must weigh less than 1.5 kilograms which is approximately the weight of a standard laptop. The required instrumentation for this test is a measure tape and a weight scale.

### **Fluid dynamics prototype test**

One of the main features that the bioreactor prototype must have is that the flow provides a proper wall shear stress to the scaffold. To perform this test an experiment has to be constructed. To construct the experiment the person in charge must follow the provided guidelines in the design of the experiment sub-section to determine the geometry and fluid properties of the model to have a proper prediction of the wall shear stress. Furthermore, once the geometry and the fluid properties have been determined, the following instruments are suggested to perform this validation test:

- Acrylic transparent tube with previously calculated length and internal diameter
- Water pump
- Flowrate control system
- Cylindrical test sections with previously calculated diameter
- Hot film gauge to measure wall shear stress

### **SAFETY THROUGH DESIGN**

When developing a project, it is important to identify any possible risk that may be encountered along the way. In this project, risks have been distributed in the following categories: technical, operational, financial, and legal. The following table presents a brainstorm of risks that have been considered to be possibly encountered during the project.

Table 14 General risks identification

<b>Risk Area</b>	<b>Risk Description</b>		
<b>Technical</b>	Bioreactor chamber diameter	Entrance length	Modular design of the complete system
	Height of the cylindrical perfusion chamber	pH meter for reservoirs	Reservoirs final shape
	Material the scaffold will be made of	CFD simulations complexity	
	Achieve fully developed flow	**Manufacture (extra)	
<b>Operational</b>	Volumetric flow control / automatization	Cells contamination	
	Damaging cells	pH control. Alert when not in optimum levels	
	** Dissolved oxygen control (extra)		
<b>Financial</b>	3D Printer	Piping	
	CO2 Incubator	Flasks	
	Peristaltic Pump	Non-biodegradable Polymer	
<b>Legal</b>	Copyright issues		

Continuing with the analysis a quantitative evaluation is performed. For this, a 5x5 matrix is created, which will serve as a parameter to evaluate the brainstormed risks presented in Table 14.



Table 15 5x5 Risk Matrix quantitative evaluation

		SEVERITY / IMPACT				
LIKELIHOOD		1	2	3	4	5
1		<b>LOW</b> 1	<b>LOW</b> 2	<b>LOW</b> 3	<b>MEDIUM</b> 4	<b>MEDIUM</b> 5
2		<b>LOW</b> 2	<b>MEDIUM</b> 4	<b>MEDIUM</b> 6	<b>HIGH</b> 8	<b>HIGH</b> 10
3		<b>LOW</b> 3	<b>MEDIUM</b> 6	<b>HIGH</b> 9	<b>HIGH</b> 12	<b>HIGH</b> 15
4		<b>MEDIUM</b> 4	<b>HIGH</b> 8	<b>HIGH</b> 12	<b>EXTREME</b> 16	<b>EXTREME</b> 20
5		<b>MEDIUM</b> 5	<b>HIGH</b> 10	<b>HIGH</b> 15	<b>EXTREME</b> 20	<b>EXTREME</b> 25

Using the quantitative parameters from Table 15 an organized evaluation of the risks presented in Table 14 is performed. It should be mentioned that some risks presented in Table 14, can be paired together or encompassed in a more general definition, this is why in the following table adjustments are made. The risks identified as “design risks” are colored in sky-blue for better identification.

Due to the nature of this project, the great majority of important risks are considered directly related to the entire design process. Thus, the abundance of high-level risks, colored in red.

*Table 16 Tabulated assessment for 12 most important risks*

CODE:	DESIGN RISKS	IMPACT/ LIKELIHOOD	PRIORITY
BP003	Volumetric flow control / automatization	5*4	20
BP009	pH control. Alert when not in optimum levels	4*3	12
BP011	Sizing of the bioreactor chamber	5*2	10
BP002	Porosity and design of the scaffold	5*5	25
BP004	Achieve fully developed flow	5*4	20
BP010	CFD simulations complexity	4*3	12
BP005	Design of the reservoirs	5*4	20
BP006	Modular design of connected systems	5*4	20
BP001	Cells contamination	5*5	25
BP007	Damaging cells	5*4	20
BP012	Manufacture	2*4	8
BP008	Copyright issues	5*3	15

At first glance, in Table 16 the risk's number may seem disordered, but it is structured prioritizing the crucial eight design risks.

Using the information in Table 16 it is important to create a plan of action to tackle and overcome the considered risks. This detailed plan of action is presented in the following matrix.

*Table 17 Final risk control matrix*

RISK NUMBER	RISK DESCRIPTION	RISK IMPACT	RISK LIKELIHOOD	RISK LEVEL / PRIORITY	DECISION TAKEN	STATUS	RESPONSIBILITY
BP001	Bacteria inside the system can have serious consequences	5	5	25	Reduce: sources of infection that come from material selection for example	Active	Nicolas Anguisaca
BP002	Final scaffold design causes underdeveloped flow	5	5	25	Reduce: regular and uniform pore dimensions reduce risk high probability	Active	Erick Lamiña
BP003	Uncontrolled volumetric flow can be detrimental to cells	5	4	20	Implement: enable a control system to regulate the adequate flow	Active	Kevin Taday
BP004	Underdeveloped turbulent or laminar flow damages cells optimal growth	5	4	20	Develop: size final design according to calculations and simulations	Active	Kevin Orbea
BP005	Reservoirs need twice as much volume as the bioreactor	5	4	20	Delay: final concept and volume determine after initial calculations	Active	Nicolas Anguisaca
BP006	Greater number of pieces, greater ease of contamination	5	4	20	Reduce: compact design allows easier manipulation and cleanability	Active	Erick Lamiña
BP007	Excessive shear stress causes cell death	5	4	20	Avoid: exceedingly fast flow circulation in the medium is damaging	Active	Kevin Taday
BP008	Unpredictable similar concepts or designs may appear	5	3	15	Prevent: double-check previous patents and bioreactors on the market	Active	Kevin Orbea
BP009	Unbalanced pH is harmful for the cells	4	3	12	Reduce: search for pH meters to be used inside the reservoirs	Active	Nicolas Anguisaca
BP010	Longer simulation processing time and mesh complexity	4	3	12	Avoid: gradual analysis and previous calculations prevent oversizing	Active	Erick Lamiña
BP011	Incorrect sizing parameters cause accelerated deterioration	5	2	10	Reduce: selection criteria helpful to point out the best design option	Active	Kevin Taday
BP012	Difficult access to manufacturing methods inside the country	2	4	8	Assign: search for different providers and manufacturers	Active	Kevin Orbea

Finally, it is important to explain how the Risk Control Matrix works. For that purpose, the first two risks with the highest priority will be used.

BP001 refers to the cell's contamination. The perfusion bioreactor system allows a controlled structure that can maintain specific conditions of carbon dioxide (CO<sub>2</sub>), temperature, dissolved oxygen, and relative pH. However, as with any living being, the proliferation of unwanted organisms occurs. Bacteria, fungi, and dead cells from the scaffold cause high-level contamination in the medium that circulates the entire bioreactor system. Therefore, any contaminant inside the structure can have serious consequences. This is why the decision to reduce possible sources of infection was taken. It affects everything, from the selection of materials to build the bioreactor, reservoirs, and piping to avoid ninety-degree angles as much as possible. The perfusion chamber, for instance, was designed as a cylindrical column for the same reason, the same applies to the design of the reservoirs.

BP002 talks about the design of the scaffold and what that implies. In this subcomponent of the whole design process, one of the biggest values for impact appears and with reason. The scaffold is where the cells bundle-up, interact, feed, reproduce, and more. It also protects them from the strong shearing stress that can be produced by the flow of medium. Thus, a scaffold that does not maximize area/volume proportion or worst of all, breaks in half, is not an option. So, the planned solution is to reduce the likelihood of a negative event occurring by defining a known porosity size, selecting a strong non-biodegradable material (polymer, stainless steel, etc.), and designating a specific volume. On top of that, possible ways of manufacturing are also considered but as an extra step. Future calculations and simulations will also influence the scaffold final design. In the end, it is part of the whole team's responsibility more than just one person as it is with most of the risks listed in this analysis.

## MAINTENANCE AND OPERATING MANUAL





### General description and features

This bioreactor system uses a three-dimensional cell culture technique, which provides mechanical stimulus to ensure a proper mass transfer as well as nutrients transport so the cells can grow and proliferate adequately. This bioreactor uses perfusion as a driven mechanism for mass transfer, which will be performed inside of a clear plastic chamber where a 3D printed porous scaffold will be placed. Perfusion requires a flow which will be provided by a peristaltic pump that will also help to simulate physiological flow conditions. This bioreactor system also provides an easy operation since it presents a built-in automated flowrate regulator as well as a pH sensor that will alert when the nutritious medium needs to be changed.

### List of parts

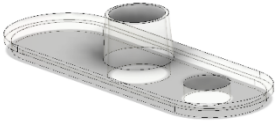
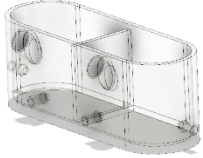
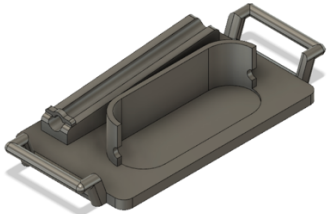
*Table 18 Bioreactor system list of parts*

No	Name	Part Number	Quantity	Image
1	Bioreactor Sealing Top Cap	PB001	1	
2	Bioreactor Sealing Bottom Cap	PBA001	1	
5	Bioreactor Chamber	PB003	1	

No	Name	Part Number	Quantity	Image
6	Reservoir Cap	PB004A1	1	
7	Reservoir	PB004A2	1	
8	System Tray	PB005	1	
9	System Connection Tubes	PB006	1 (1.5 m)	
10	Peristaltic Pump	PB007	1	
11	Worm Drive Hose Clamp	PB008	6	

No	Name	Part Number	Quantity	Image
12	Arduino Uno	PB009	1	
13	YFS201 Water Flow Sensor	PB010	1	
14	Analog pH Sensor Kit	PB011	1	
15	Servo Motor	PB012	1	
16	Plastic Ball Valve	PB013	1	

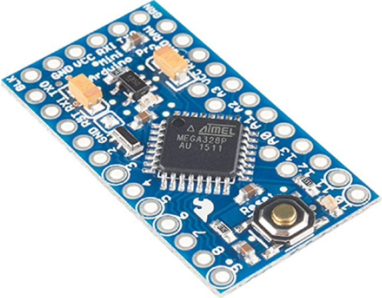
No	Name	Part Number	Quantity	Image
17	LED	PB014	2	
18	Arduino mini	PB015	1	

### Safety Information

- Before operating the system, the user needs to make sure that the bioreactor chamber and its components as well as the reservoir and its components are sterilized to avoid any contamination to the cells and their nutritious medium.
- Be careful when manipulating the plastic components especially try to avoid excessive pressure on them, because that may cause cracks that can lead to a potential medium for bacteria development.
- When changing the nutritious medium inside the laminar flow chamber avoid passing hands or any object over any inlet or outlet of the system.
- Avoid to over manipulate the control sensors.
- Manipulate the cells in the scaffold and the medium inside a controlled space since the lack of control can produce a biohazard risk.



## **General operating notes**

### **Startup**

- Screw the bioreactor sealing top cap to the bioreactor chamber.
- Place and secure the scaffold to the scaffold support ring of the bioreactor sealing bottom cap. Then screw the bottom cap to the bottom of the bioreactor chamber.
- Place the assembled bioreactor chamber and the reservoir on the tray.
- Connect the bioreactor chamber and the reservoir with the provided tube and secure the inlet and outlets with the worm drive hose clamps.
- Connect the longer provided tubes to the inlet of the bioreactor chamber and the outlet of the reservoir and secure them with the worm drive hose clamps.
- Insert the pH sensor inside the top side of the hole of the reservoir.
- Place the tray with all its components inside an incubator with ends of the longer tubes outside the incubator.
- Connect the longer tube that comes from the bioreactor chamber to the outlet of the peristaltic pump and the longer tube that comes from the reservoir connects it to the flow meter that is placed at the inlet of the peristaltic pump.
- Connect the peristaltic pump and the current transformer of the control system to a power supply.
- Set the desired flow rate with the nob at the peristaltic pump and begin operation.

### **Operating routine**

- While the system is operating, pay attention to the pH sensor indicator
- Once the pH sensor is activated the user must take action and change the nutritious medium inside a laminar flow chamber to avoid any possible contamination.

### **Shut down**

- Turn off the peristaltic pump and unplug the control system from the power supply.

- Move the tray to a laminar flow chamber and disassemble the system. Be careful of any contamination risk by passing a hand or an object over an outlet or inlet of the system.
- Take the scaffold apart from the ring support and manipulate it considering any biohazard risks.
- Clean and sanitize the components of the system.

### Storage

- All the components except the pump can be placed back to the tray and stored inside the incubator turned off or placed in a drawer that is not exposed to too much humidity or dust.

### Operating variable ranges

- **Flow rate:** 15 to 30  $\frac{ml}{min}$
- **Temperature:**  $37 \pm 1.1$  °C
- **Nutritious medium pH:** 7 to 7.4 (preferring an alkaline medium)

### Maintenance

- Before and after using the system, the components must be sterilized.
- Change for new connecting tubes after 10 operating cell culture cycles to avoid any biohazard risk.
- To assure the accuracy of the sensors it is recommended to renew them every 6 months.
- Check the peristaltic pump manufacturer user manual for the appropriate maintenance.

User relevant assembly drawings

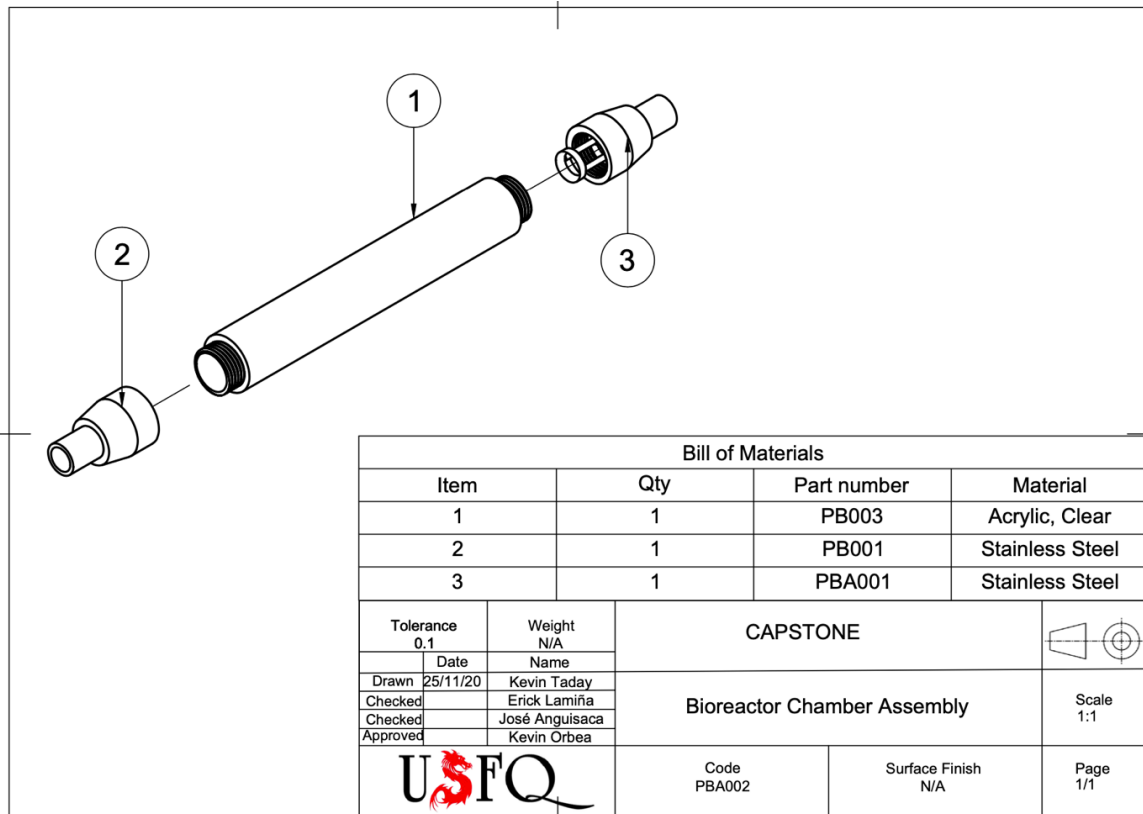

Figure 46 Bioreactor Chamber Assembly

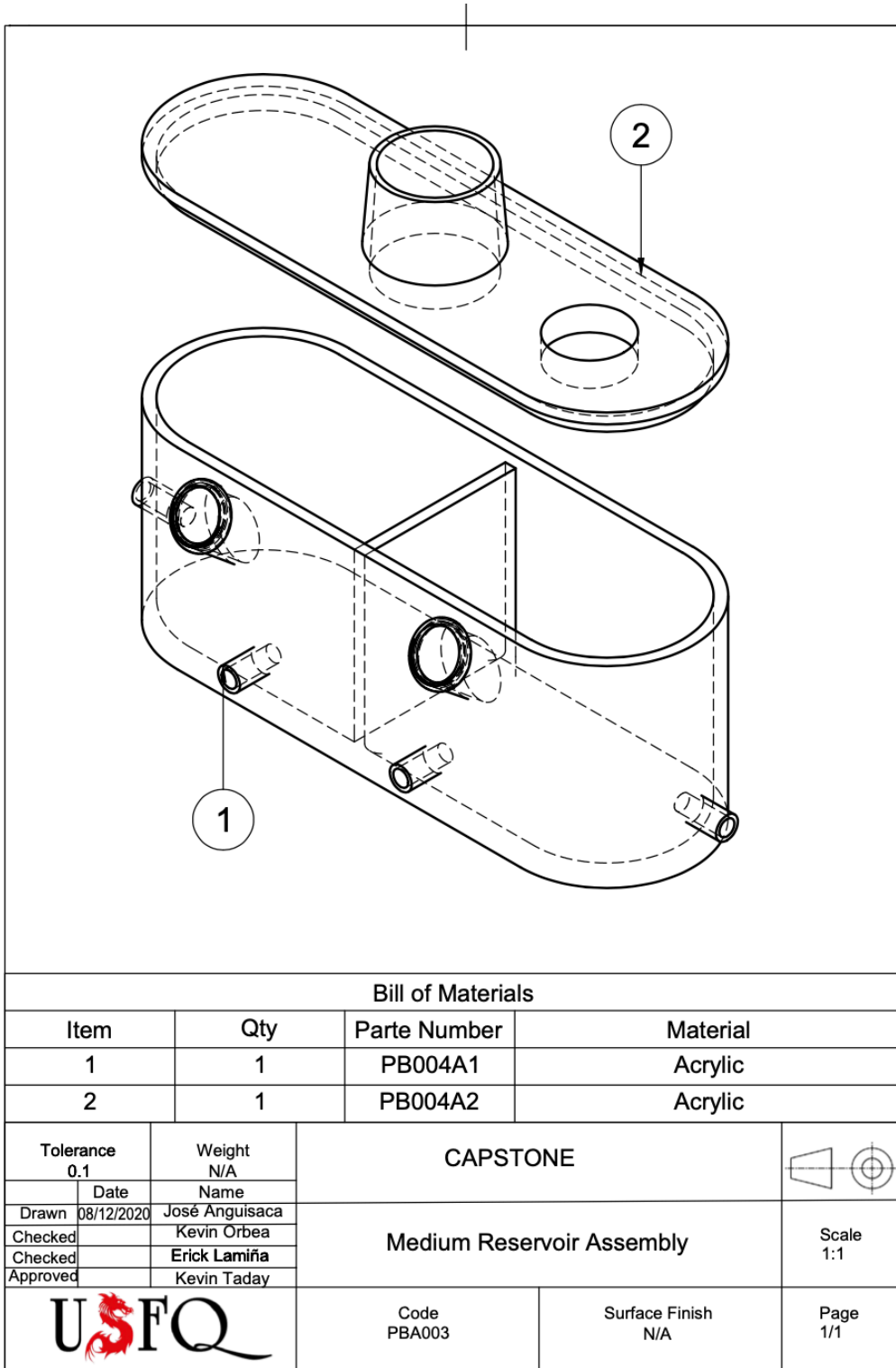

Figure 47 Medium Reservoir Assembly

## RESULTS

### Fluid dynamics analysis

The analytical fluid dynamic analysis was performed using an EES code, which can be found in Appendix E. The code run in EES has been done in such a way that two parametric studies were possible. The first parametric study considers the flow rate as an independent variable ranging from 10 to 85 ml/min which is the operational range of flowrates that the peristaltic pump can give. The second parametric study considers the bioreactor chamber diameter as an independent variable ranging from 1 to 2 cm. These parametric studies were performed to evaluate the actual values of the analytical model and to evaluate various possible design parameters and try to optimize them. The results of both of these studies are presented below.

*Table 19 Analytical analysis parametric study with flowrate variation*

*Source: EES*

Run	$Q \left( \frac{ml}{min} \right)$	$U_{\infty} \left( \frac{m}{s} \right)$	$le \text{ (cm)}$	$Re$	$\tau_w \text{ (Pa)}$	$\tau_w \left( \frac{dyn}{cm^2} \right)$
1	10	0.002122	1.829	30.49	0.01224	0.1224
2	15	0.003183	2.744	45.73	0.02248	0.2248
3	20	0.004244	3.658	60.97	0.03461	0.3461
4	25	0.005305	4.572	76.21	0.04836	0.4836
5	30	0.006366	5.487	91.45	0.06358	0.6358
6	35	0.007427	6.401	106.7	0.08011	0.8011
7	40	0.008488	7.316	121.9	0.09788	0.9788
8	45	0.009549	8.23	137.2	0.1168	1.168
9	50	0.01061	9.144	152.4	0.1368	1.368
10	55	0.01167	10.06	167.6	0.1578	1.578
11	60	0.01273	10.97	182.9	0.1798	1.798
12	65	0.01379	11.89	198.1	0.2027	2.027
13	70	0.01485	12.8	213.4	0.2266	2.266
14	75	0.01592	13.72	228.6	0.2513	2.513
15	80	0.01698	14.63	243.8	0.2768	2.768
16	85	0.01804	15.55	259.1	0.3032	3.032

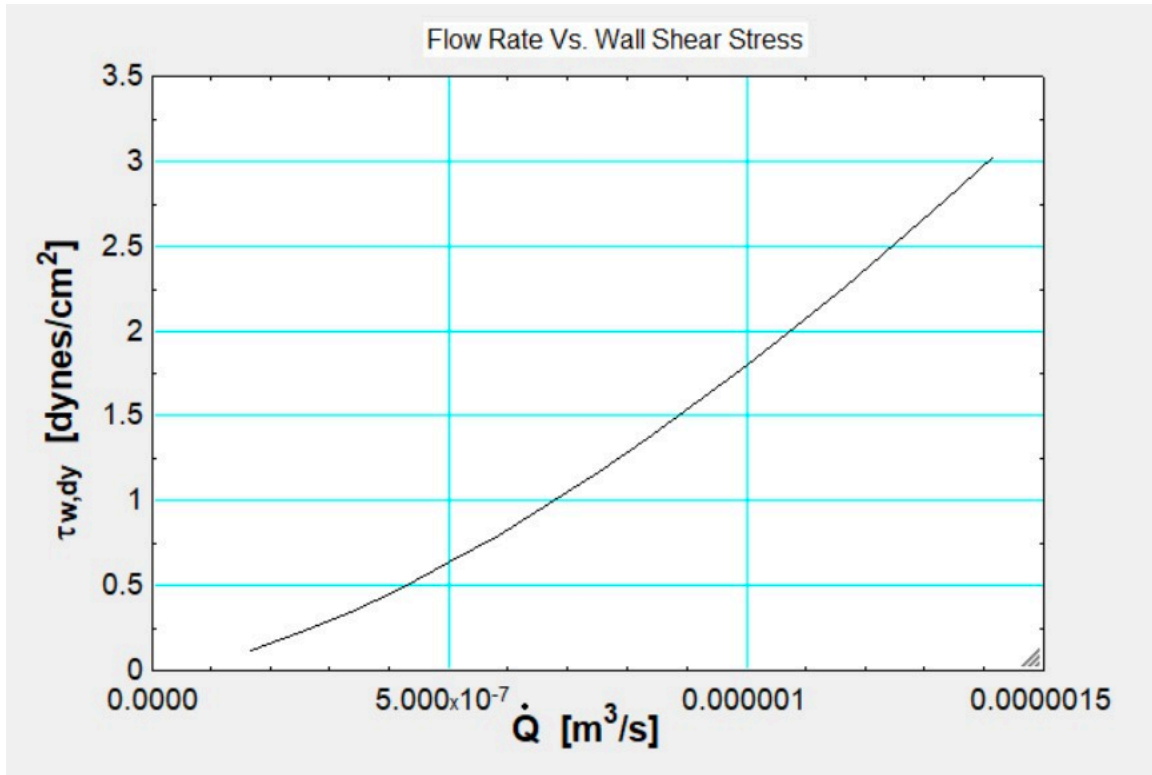

Figure 48 Flowrate vs wall shear stress

Source: EES

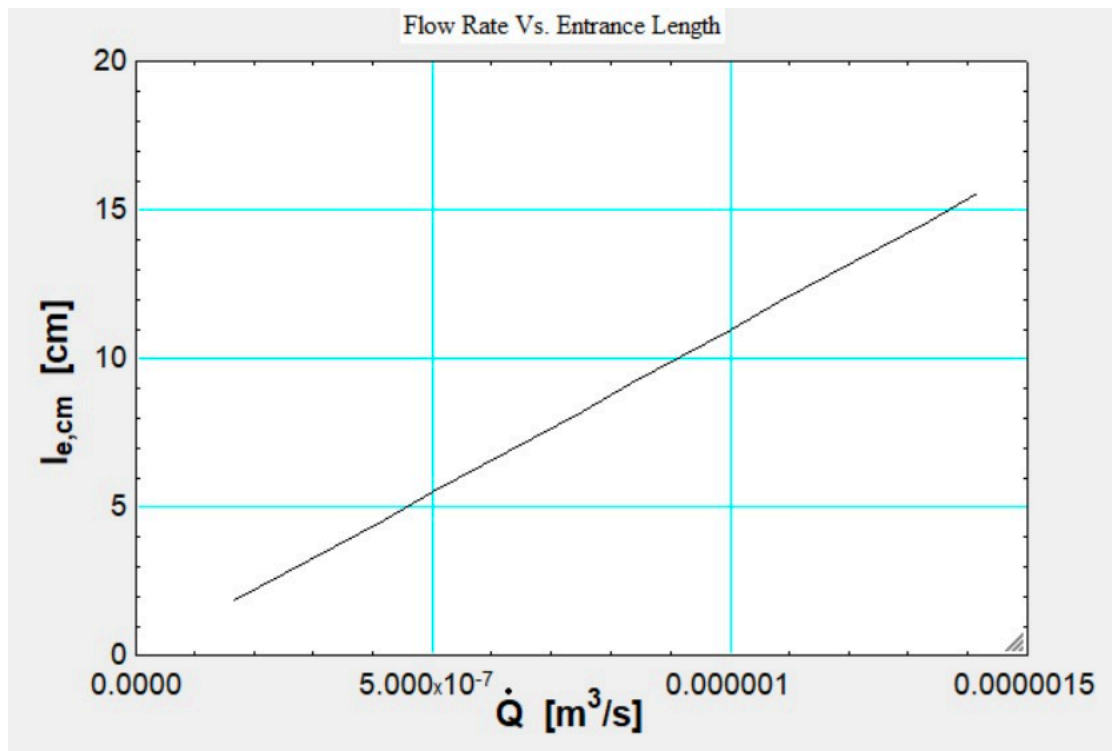

Figure 49 Flowrate vs entrance length

Source: EES

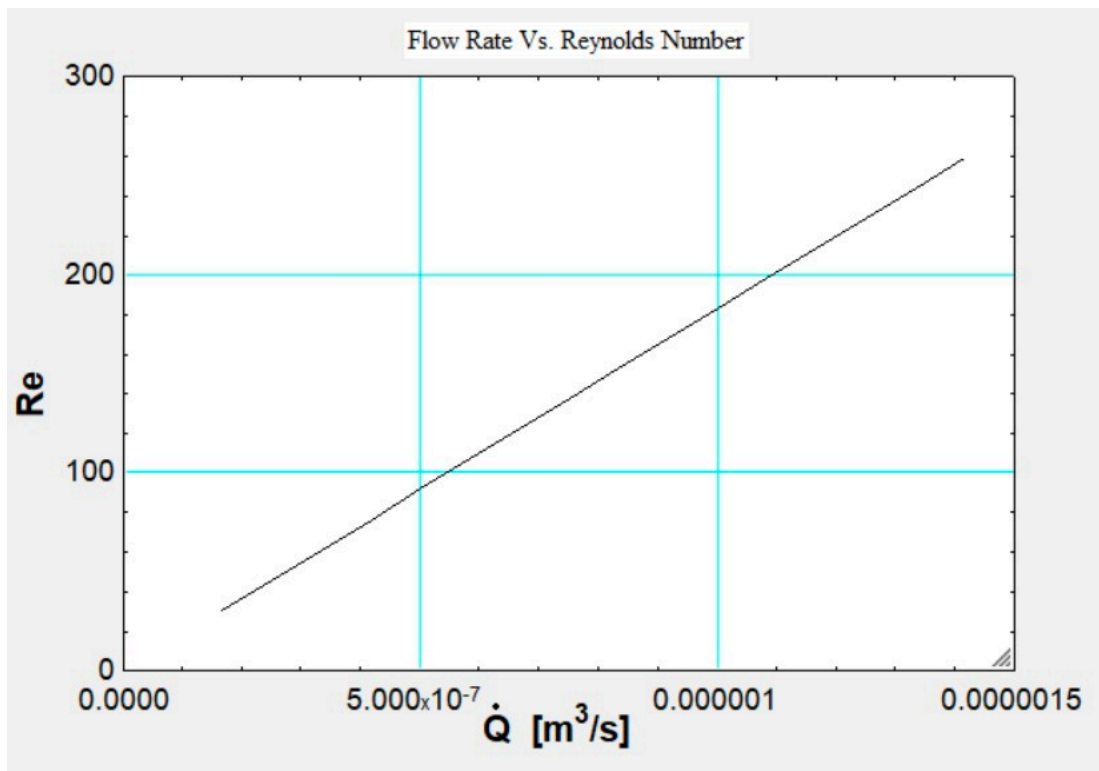

Figure 50 Flowrate vs Reynolds number

Source: EES

Table 20 Analytical analysis parametric study with bioreactor chamber diameter variation

Source: EES

Run	$D_B$ (cm)	$l_e$ (cm)	$Re$	$\tau_w$ ( $\frac{dyn}{cm^2}$ )	$U_\infty$ ( $\frac{m}{s}$ )
1	0.01	5.487	91.44	0.6357	0.006366
2	0.011	5.487	83.13	0.4776	0.005261
3	0.012	5.487	76.2	0.3679	0.004421
4	0.013	5.487	70.34	0.2894	0.003767
5	0.014	5.487	65.32	0.2317	0.003248
6	0.015	5.487	60.96	0.1884	0.002829
7	0.016	5.487	57.15	0.1552	0.002487
8	0.017	5.487	53.79	0.1294	0.002203
9	0.018	5.487	50.8	0.109	0.001965
10	0.019	5.487	48.13	0.09268	0.001763
11	0.02	5.487	45.72	0.07946	0.001592

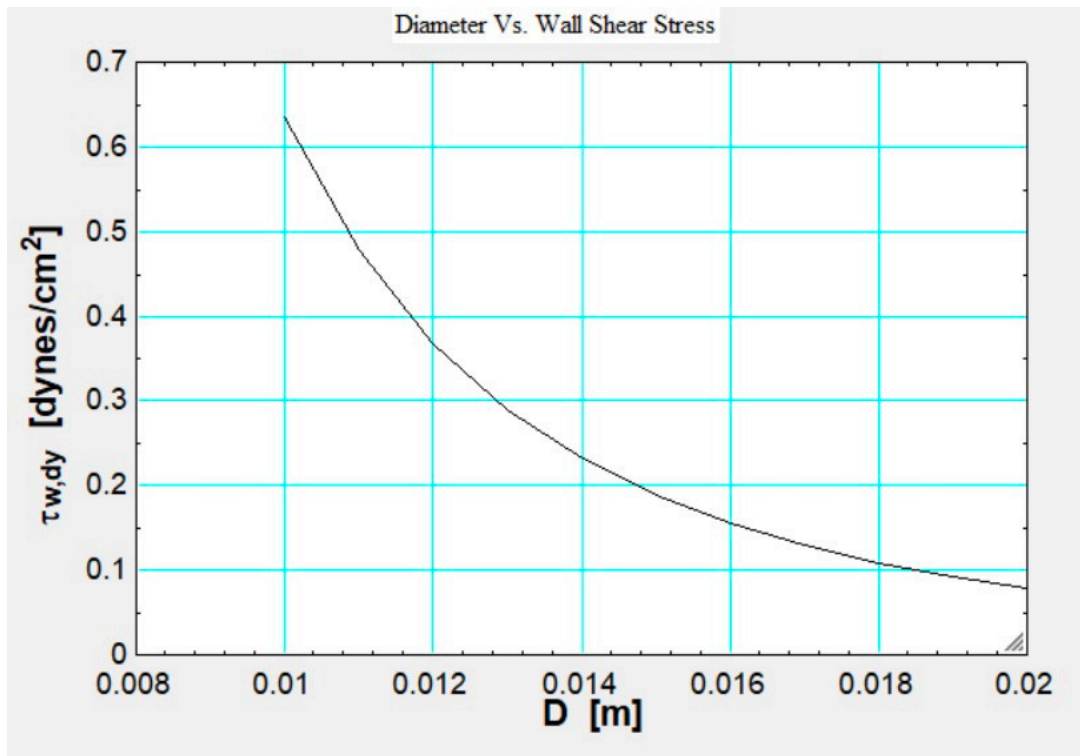

Figure 51 Bioreactor chamber diameter vs wall shear stress

Source: EES

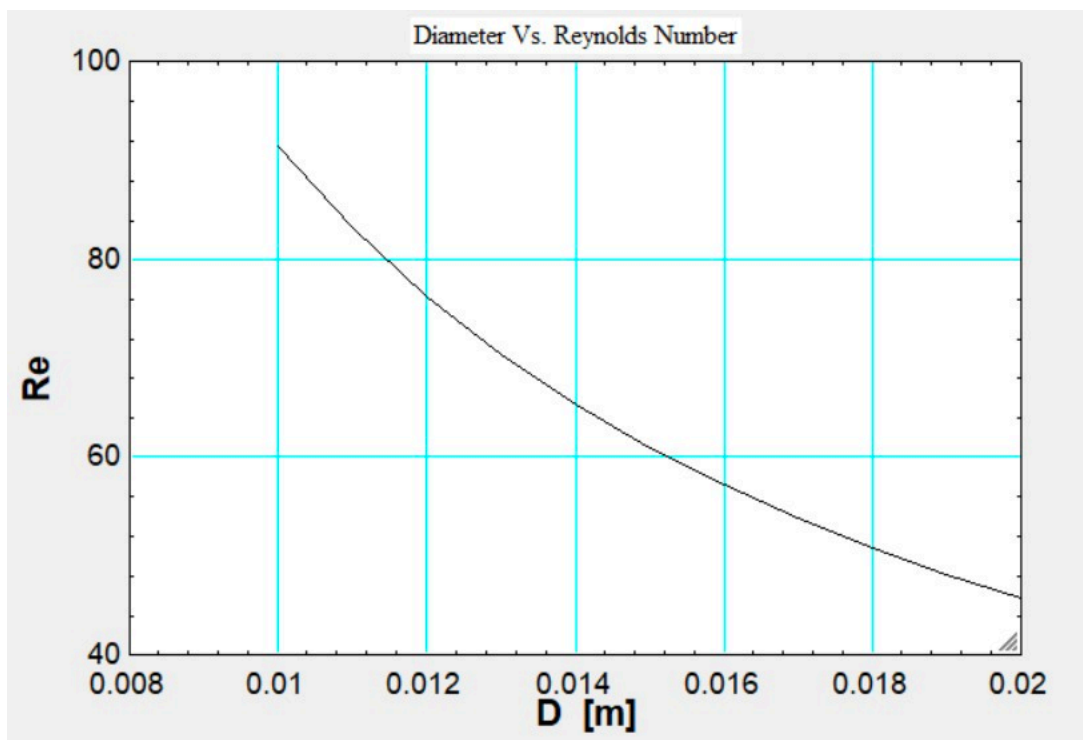

Figure 52 Bioreactor chamber diameter vs Reynolds number

Source: EES



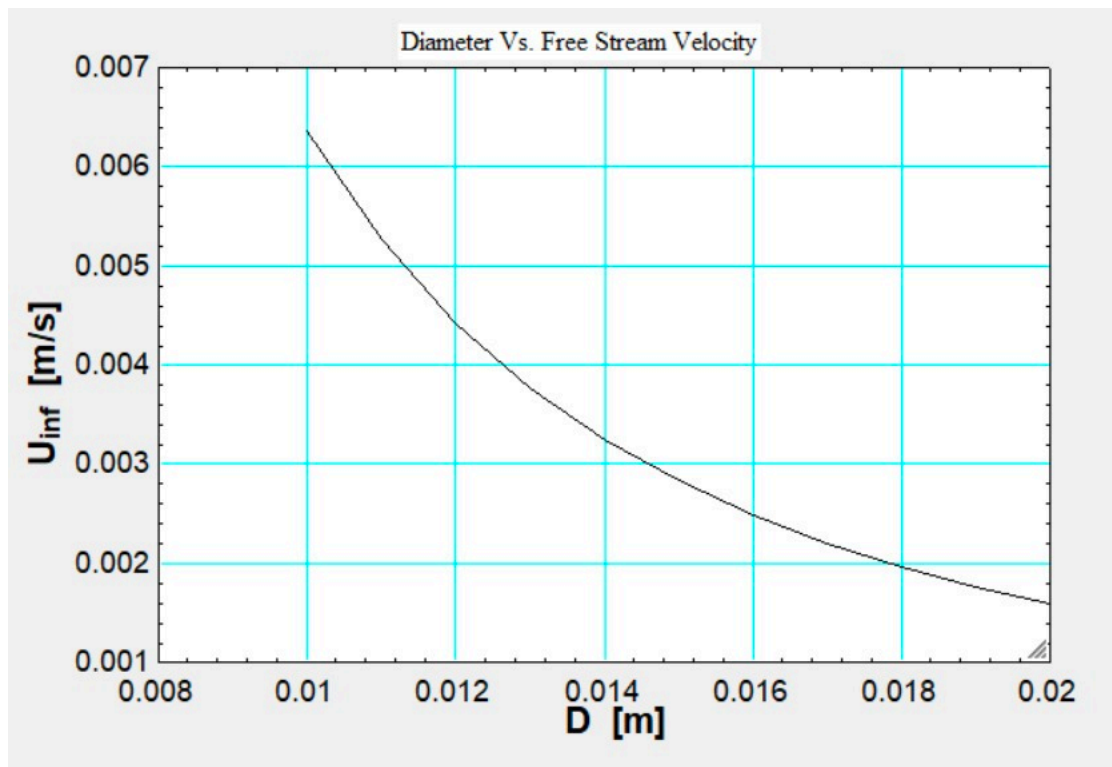

Figure 53 Bioreactor chamber diameter vs Freestream velocity

Source: EES

CFD simulations were performed to validate the results of the analytical analysis. It is for this reason that both simulations are run with different parameters. For the two-dimensional simulation, the parameters were set up as the ninth analytic run in Table 19. The results for the two-dimensional CFD simulation are presented below.

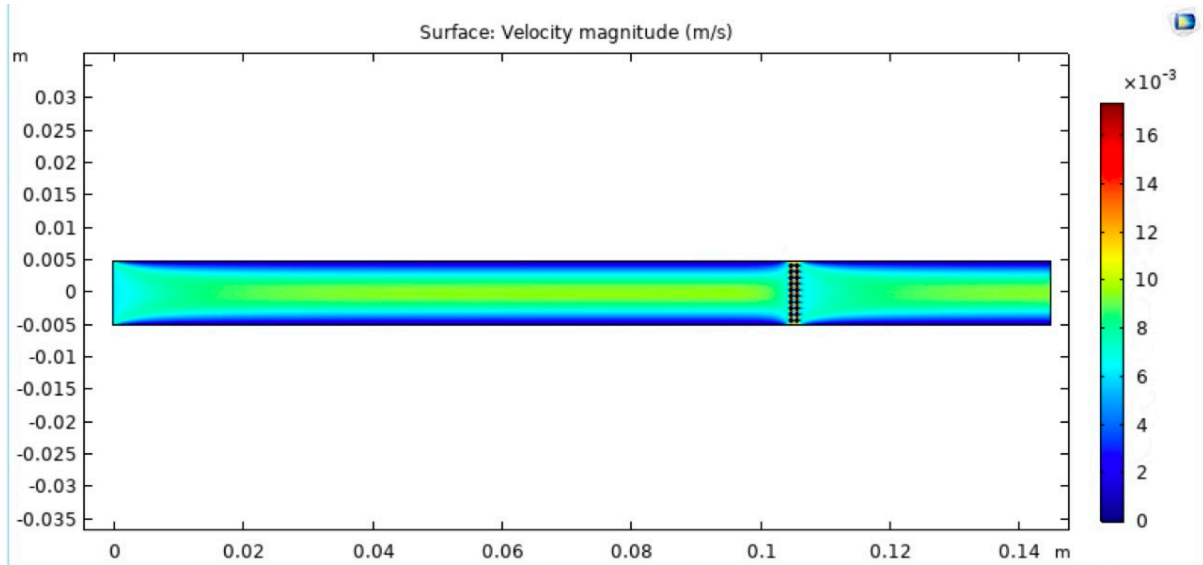

Figure 54 Flow velocity distribution throughout the bioreactor chamber and around the scaffold structural members

Source: COMSOL

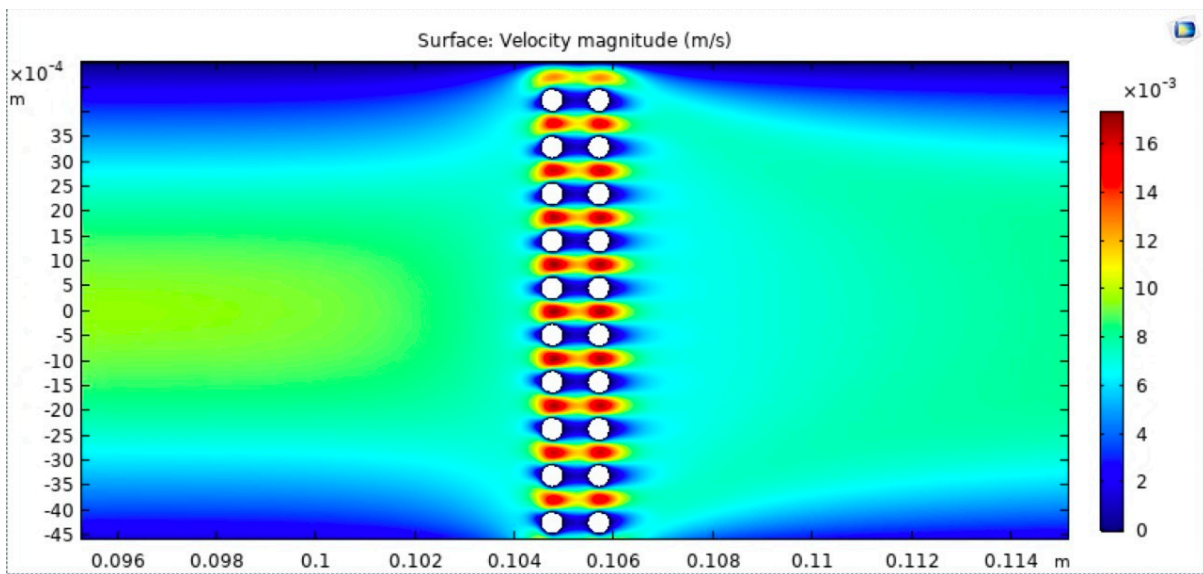

Figure 55 Close up look of the Flow velocity distribution around the scaffold structural members

Source: COMSOL

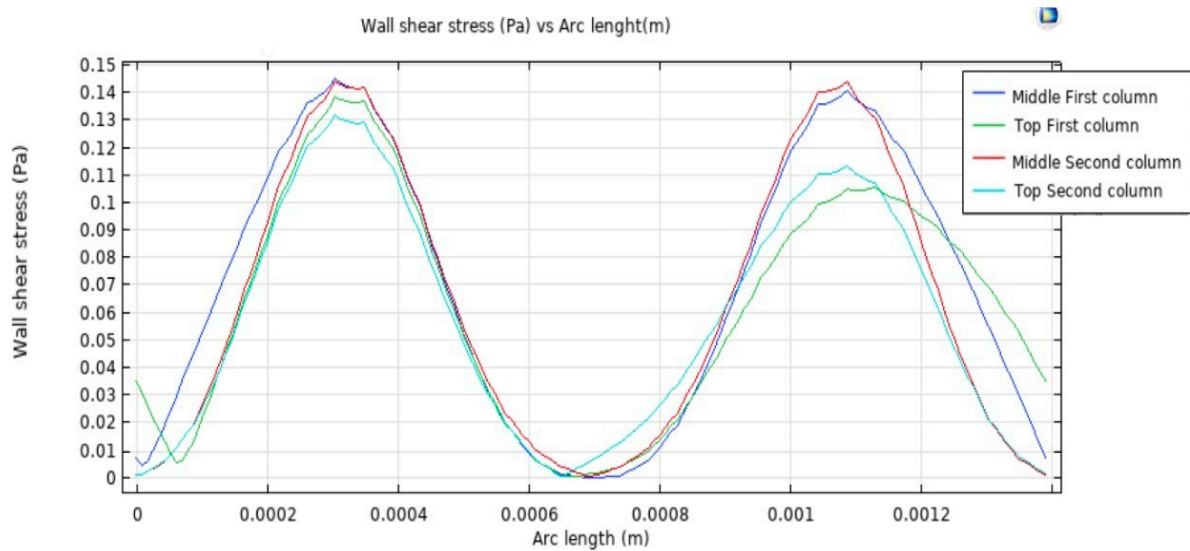

Figure 56 Wall shear stress vs arc length at the surface of the scaffold structural members

Source: COMSOL

For the three-dimensional simulation, the parameters were chosen as the fifth run of the analytical analysis shown in Table 19. It should be mentioned that the parameters for the fifth run are the ones that the customer had chosen as ideal conditions for operating the bioreactor system. The results for the three-dimensional CFD simulation are presented below.

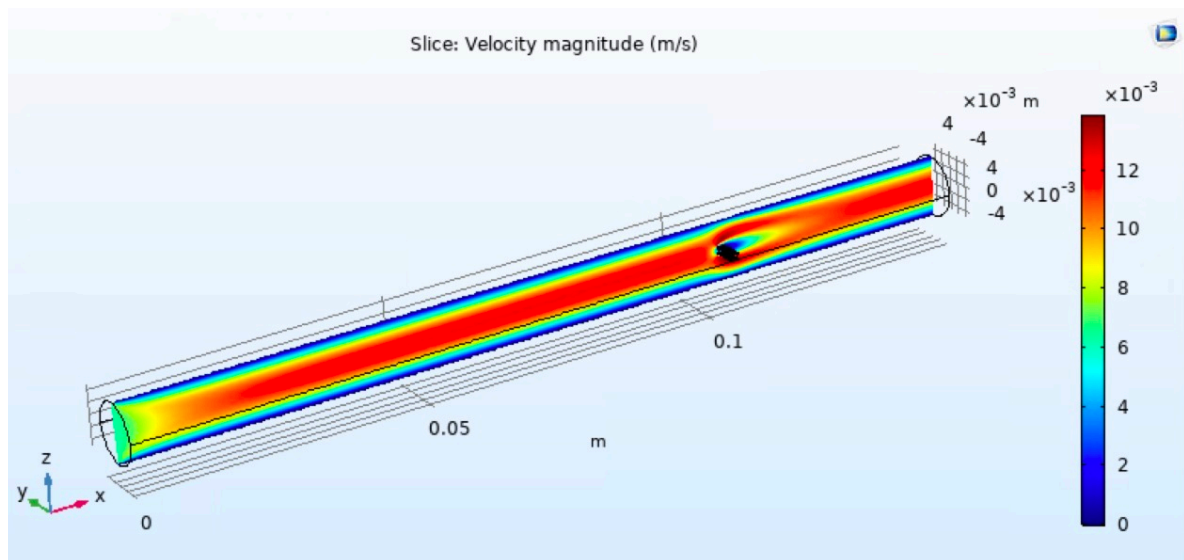

Figure 57 Perspective view of the flow velocity distribution throughout the bioreactor chamber and around the scaffold structural members

Source: COMSOL

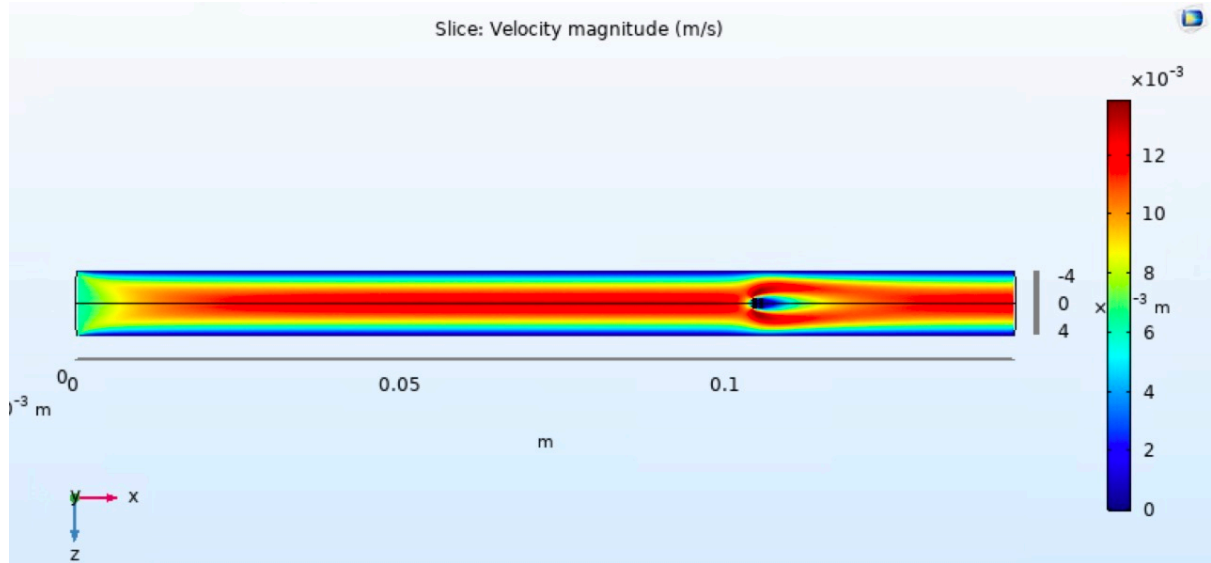

Figure 58 XZ plane view of the flow velocity distribution throughout the bioreactor chamber and around the scaffold structural members

Source: COMSOL

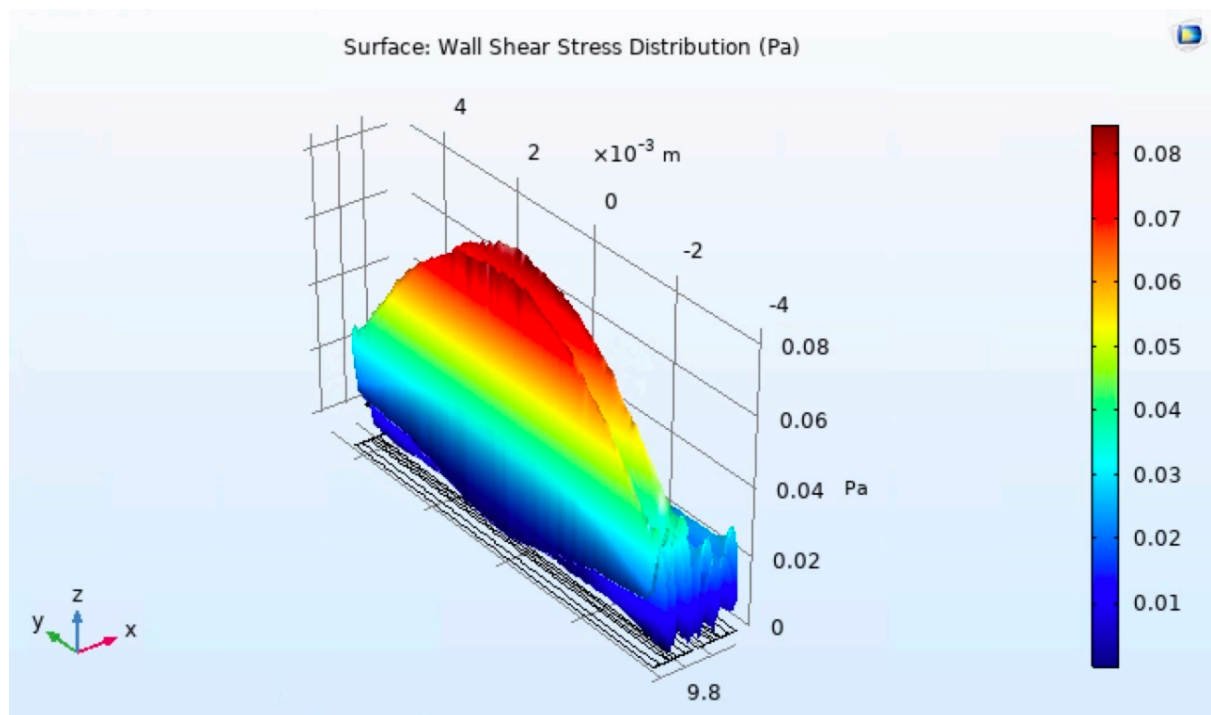

Figure 59 Wall shear stress distribution at the surface of the scaffold structural members

Source: COMSOL

## Energy analysis

The energy analysis to determine the pressure drop has been computed using EES. The code for this analysis can be found in Appendix E. The following table presents the results of relevant variables of this analysis

*Table 21 System Pressure drop EES results*

*Source: EES*

EES Results	
Hydraulic Radius ( $R_h$ )	0.000111 [m]
Hydraulic Diameter ( $D_h$ )	0.00635 [m]
Friction Factor ( $f$ )	0.3499
Total tube length ( $L_t$ )	1.5 [m]
Sum of accessories resistance coefficient ( $\sum K$ )	8.56
Pressure drop at the bioreactor chamber ( $\Delta P_{chamber\ bioreactor}$ )	42.87 [Pa]
Total Pressure drop in the system ( $\Delta P_{1-2}$ )	50.21 [Pa]

## Design of experiments

Using the design of experiments guideline an experiment was designed with the following parameters

Table 22 Experiment design parameters

<b>Variable</b>	<b>Prototype Dimension</b>	<b>Model Dimension</b>
Model's Scaffold structural member diameter ( $m$ )	4.44E-4	3.5E-3
Model's bioreactor chamber diameter ( $m$ )	0.01	0.08
Model's free stream velocity ( $\frac{m}{s}$ )	0.006366	8.00E-04
Flowrate ( $\frac{m^3}{s}$ )	5.00E-04	1.61E-5
Entrance length ( $m$ )	0.05	0.44
Re	91.45	91.45
Fluid density ( $\frac{kg}{m^3}$ )	993.3	993.3
Fluid viscosity ( $s Pa$ )	0.0006915	0.0006915

The prototype parameters shown in the above table have been chosen from the customer's ideal bioreactor operation conditions.

An experiment was craft based on the model parameters from Table 22. However, due to the lack of equipment, the experiment was only able to demonstrate the laminar flow regime inside the bioreactor chamber as seen in the following pictures.





*Figure 60 Experiment model setup*

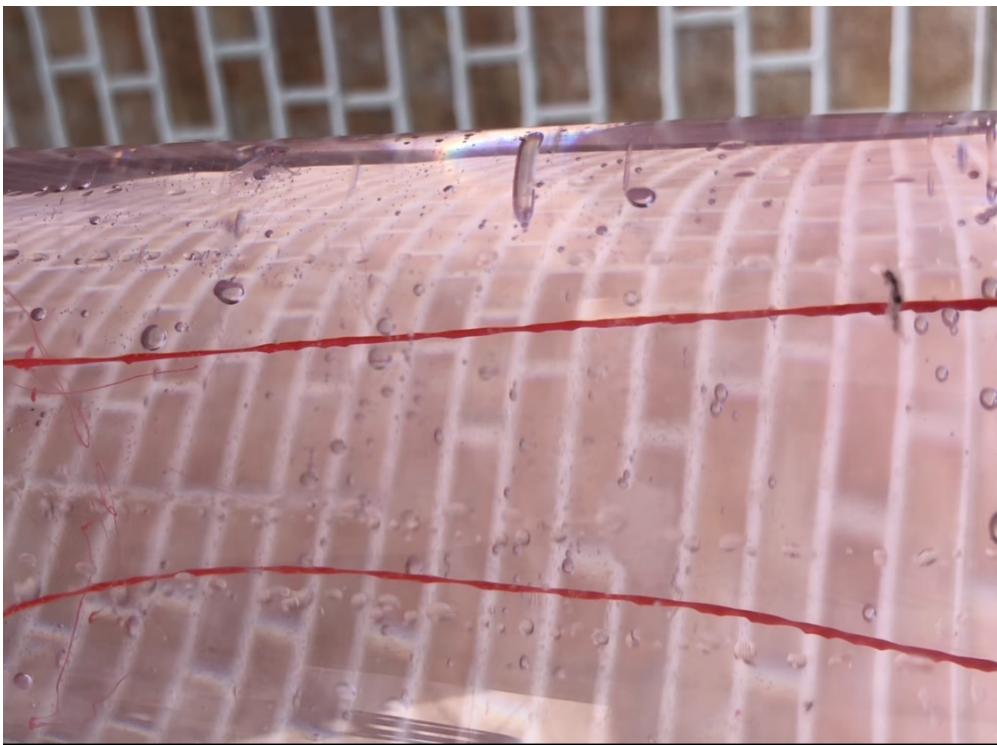

*Figure 61 Laminar flow ink trace paths in experiment model*

## DISCUSSION

The fluid dynamics analytical analysis shown in Table 19 proves that the wall shear stress experienced at the scaffold structural members is within the range that literature has established for an optimal cell culture process, this range is 0.1 to 25  $\frac{\text{dynes}}{\text{cm}^2}$  or 0.01 to 2.5 Pa (Olufemi E. Kadri, Cortes Williams III, Vassilios Sikavitsas, Roman S. Voronov, 2018). Also, to prove that the mathematical model used to calculate analytically the wall shear stress is correct a two and three-dimensional CFD simulations were performed. As seen in Figure 56 which corresponds to the 2D simulation and was set up with a freestream velocity equal to the 9<sup>th</sup> run of analytical study from Table 19, the maximum wall shear stress that the scaffold structural members experience is close to 0.14 Pa, which is close to the value of 0.1368 Pa for the wall shear stress calculated analytically in the 9<sup>th</sup> run of Table 19. The same can be said regarding the three-dimensional simulation which was set up based on the 5<sup>th</sup> analytical run from Table 19. For this simulation the maximum wall shear stress that the scaffold structural members experience is close to 0.08 Pa, which again is somewhat close to the wall shear stress calculated analytically for the 5<sup>th</sup> run in Table 19, which is 0.06358 Pa. The small discrepancy between the wall shear stress values from the 3D simulation and the analytical calculation can be accounted to the fact that the analytical analysis model was developed for an infinite cylinder that will not feel the effect of any vortex generation at its tips. Nevertheless, for both simulation cases, it can be seen that the wall shear stress is within the stipulated optimal range and therefore it also proves the analytical model as a good first attempt for the design process.

The next key parameter that was analyzed in the fluid dynamics analysis is the entrance length of the bioreactor chamber. First of all, the analytical results for this variable are validated again with the help of the CFD simulation. As seen in both Figure 54 and



Figure 58 the flow boundary layer grows until it reaches a stable point where it doesn't change. This stabilization of the boundary layer happens before the flow reaches the scaffold, which proves that the flow has completely developed, which again validates the analytical analysis model planted.

Now, that the analytical model has been proven to be a good tool to predict the reality it can be used to optimize the design. It has to be considered that the cells required a well-applied shear stress to spread out, that the bioreactor system must be as compact as possible, and that the cells require a not to large flow rate. From Figure 48 it can be seen that the wall shear stress increases exponentially as the flowrate increases. However, from Figure 49 it can be seen that the entrance length also increases linearly as the flowrate increases. Considering these two figures to optimize the design an optimal flow rate needs to be established. The customer suggested that the cells can properly absorb the nutrients with a flow rate of 30 ml/min therefore this will be the optimal operating flowrate. Using the 30 ml/min flow rate the entrance length is also known as seen in Table 19. Considering the entrance length, the total length of the bioreactor chamber has been established to be 14.5 cm which takes into account safety measures to allow any flowrate variance so the flow can be fully developed even if the flow rate increases. Also, this total length leaves space for a scaffold variable length that can range from 3 to 5 cm as the customer has requested. Furthermore, from Figure 51 it can be seen that the wall shear stress decreases exponentially as the bioreactor chamber diameter increases, which is why the diameter has been chosen to be 1 cm to maximize the wall shear stress.

From Table 21 it can be seen that the pressure drop that the bioreactor system will have to withstand is 50.21 Pa from this value it should be mentioned that the major pressure drop is due to the scaffold porous media which represents the 85.38 of the pressure drop. This pressure drop is considered relatively low and will not represent a challenge to the peristaltic

pump. The peristaltic pump operates at a maximum pressure of 29 psi or 199948 Pa which is more than enough to overcome the calculated pressure drop.

Figure 61 shows two streamlines while the water flows through the bioreactor chamber model. These streamlines are clear, and no eddies are created around them which proves that the flow regime in this model as well as in the prototype is laminar due to similitude analysis.

For the flowrate control system, it should be emphasized that it is implemented as a redundant control since the peristaltic pump already has a precise built-in control. This consideration allows the control system to be as simple as possible therefore no PID control is required. Another reason for the absence of a PID control is that the geometry of the bioreactor system has been designed with safety measures, as explained in the previous paragraphs, so it can overcome any flowrate invariance, which allows the control system to have a simple architecture.

## **CONCLUSIONS**

Tissue engineering benefits from the use of perfusion bioreactors, many of which have certain issues that can be improved. Therefore, the design and analysis of the actual perfusion bioreactor system aims to contribute to future research. With the help of fluid simulations, results were obtained that showed satisfactory values and magnitudes, closely related to the ones obtained in analytical form. The fact that the analytical calculations component had similar results with the COMSOL simulations, positively reinforces the decisions made for the design of the bioreactor system.

The final prototype bioreactor prototype presented in this report has been proven to a compact design that satisfactory meets all fluid dynamics requirements and has possible operating conditions for the customer's given requirements. In general terms, the project has accomplished all engineering criteria.

Finally, it should be said that all previous deliverables allowed a better organization, and understanding, of the information display in the present text. Initial budget, Gantt diagram, and Risk analysis subcomponents allow a better understanding of the steps that were followed to fulfill the objective of presenting well organized senior project design.

## **FUTURE WORK**

For further development of this bioreactor system, some areas should be examined with more detailed. The first one is the crafting of an experiment based on the guidelines provided in this experiment that can allow the measurement of the wall shear stress for further validation of the mathematical model presented in this report. The second are that should be further examined is the scaffold geometric design so it can be optimized to a better surface are where the cells can grow, also the materials that can constitute the scaffold should be further studied so the bioreactor can develop cell prosthesis that can be implemented to human beings.

## REFERENCES

Slack, J. (2018). *The Science of Stem Cells*. Hoboken, NJ, USA: John Wiley & Sons, Inc.

Grossemey, S., Chan, P., & Doran, P. (2020). Stimulation of cell growth and neurogenesis using protein-functionalized microfibrinous scaffolds and fluid flow in bioreactors. *Biochemical Engineering Journal*, 159, 1-11.

National Institute of Biomedical Imaging and Bioengineering. (2019, November). *Tissue Engineering and Regenerative Medicine*. Retrieved September, 2020 from U.S. Department of Health & Human Services:  
[https://www.nibib.nih.gov/sites/default/files/2020-06/Tissue\\_Engineering\\_Fact\\_Sheet.pdf](https://www.nibib.nih.gov/sites/default/files/2020-06/Tissue_Engineering_Fact_Sheet.pdf)

Abousleiman, R., & Sikavitsas, V. (2006). *Bioreactors for tissues of the musculoskeletal system* (Vol. 585). Boston, MA: Springer.

Fricking, P. (2016). *USA Patent No. US009428724B2*.

GE Healthcare. (2008). *Wave Bioreactor System*. Retrieved 2020 from General Electric Healthcare: [http://www.gelifesciences.co.kr/wp-content/uploads/2016/07/Cell\\_Culture\\_Procedures\\_Book\\_수정\\_v2.pdf](http://www.gelifesciences.co.kr/wp-content/uploads/2016/07/Cell_Culture_Procedures_Book_수정_v2.pdf)

Wasserman, S. (2019, September 25). *What is PMMA and how is it used in the medical world?* Retrieved December, 2020 from Ansys: <https://www.ansys.com/blog/what-is-pmma-how-it-is-used-healthcare>

Eagle Stainless Tube & Fabrication, Inc. (n.d.). *304 vs 316 Stainless Steel*. Retrieved December, 2020 from Eagle Stainless Tube & Fabrication, Inc.:  
<https://eagletube.com/about-us/news/304-vs-316-stainless-steel/>

Olufemi E. Kadri, Cortes Williams III, Vassilios Sikavitsas, Roman S. Voronov. (2018). Numerical Accuracy Comparison of Two Boundary Conditions Commonly used to

Approximate Shear Stress Distributions in Tissue Engineering Scaffolds Cultured under Flow Perfusion. *Numerical Methods in Biomedical Engineering*.

Xu, Z., Wang, N., Liu, P., Sun, Y., Wang, Y., Fei, F., . . . Han, B. (2019). Poly(Dopamine) Coating on 3D-Printed Poly-Lactic-Co-Glycolic Acid/ $\beta$ -Tricalcium Phosphate Scaffolds for Bone Tissue Engineering. *Molecules*, 24(23), 1-15.

Schlichting, H. (1979). *Boundary layer theory*. New York: McGraw Hill.

Munson, B., Young, D., & Okiishi, T. (2016). *Fundamentals of Fluid Mechanics*. Hoboken: Wiley & Sons.

Thomas Scientific. (n.d.). *Thomas Scientific*. From Thomas Mini Variable-Speed Peristaltic Tubing Pumps: [https://www.thomassci.com/Equipment/Liquid-Pumps/\\_/Thomas-Mini-Variable-Flow-Pumps](https://www.thomassci.com/Equipment/Liquid-Pumps/_/Thomas-Mini-Variable-Flow-Pumps)

T.K. Hareendran. (n.d.). *Electro Schematic*. From Working with Water Flow Sensors & Arduino: <https://www.electroschematics.com/working-with-water-flow-sensors-arduino/>

Mechatronics, N. (n.d.). *Sensor de flujo de agua 1/2" YF-S201*. From Naylamp Mechatronics: <https://www.naylampmechatronics.com/sensores-liquido/108-sensor-de-flujo-de-agua-12-yf-s201.html>

Fahad, E. (2019). *Electronic Clinic*. From ph sensor Arduino, how do ph sensors work, application of ph meter, ph sensor calibration: <https://www.electronicclinic.com/ph-sensor-arduino-how-do-ph-sensors-work-application-of-ph-meter-ph-sensor-calibration/>

Store, Arduino. (n.d.). *Arduino Store*. From GRAVITY: ANALOG PH SENSOR - METER KIT: <https://store.arduino.cc/usa/gravity-analog-ph-sensor>

American Society of Testing and Materials. (2020). *ASTM D4169-16*. From Standard Practice for Performance Testing of Shipping Containers and Systems.:

<http://www.astm.org/cgi-bin/resolver.cgi?D4169-16>

Weber, A., De Wilde, D., Chaussin, S., Adams, T., Gerighausen, S., Greller, G., & Fenge, C. (2014). *Development and qualification of a scalable, disposable bioreactor for GMP-compliant cell culture. Innovations in Cell Culture.*

# APPENDIXES

## Appendix A

Estud | BIOREACTOR



**Appendix B**



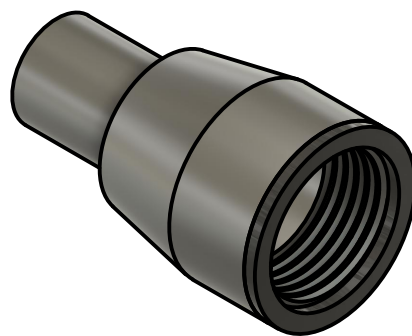
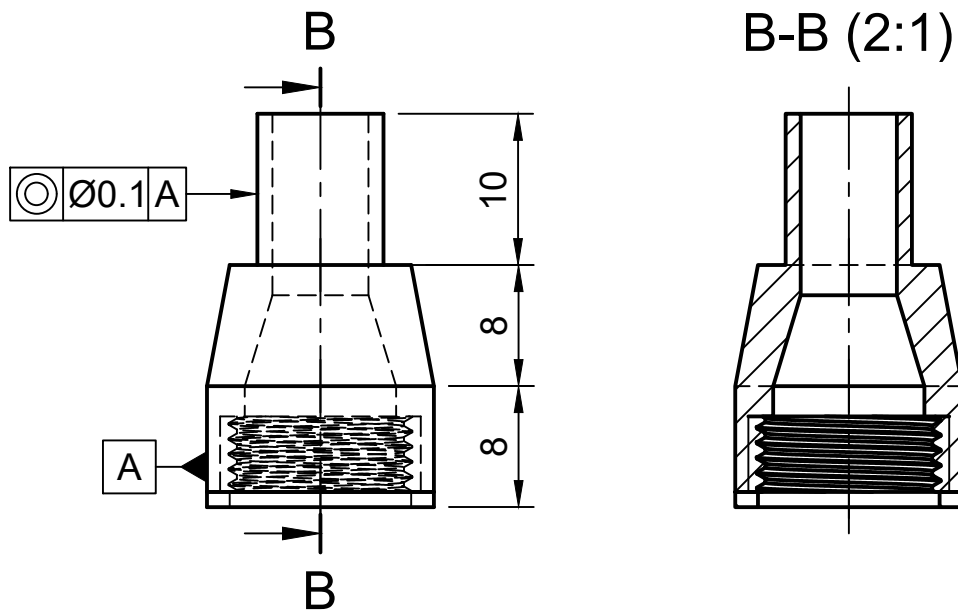
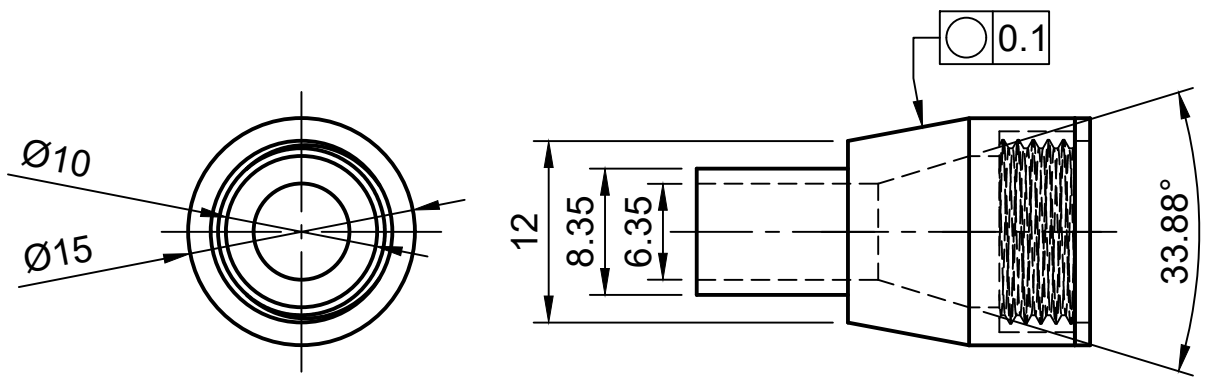

Tolerance 0.1		Weight N/A	316 Stainless Steel		
Date	Name				
Drawn	26/12/2020	José Anguisaca	Bioreactor Sealing Top Cap	Scale 2:1	
Checked		Kevin Orbea			
Checked		Erick Lamifña			
Approved		Kevin Taday			
			Code PB001	Surface Finish N7	Page 1

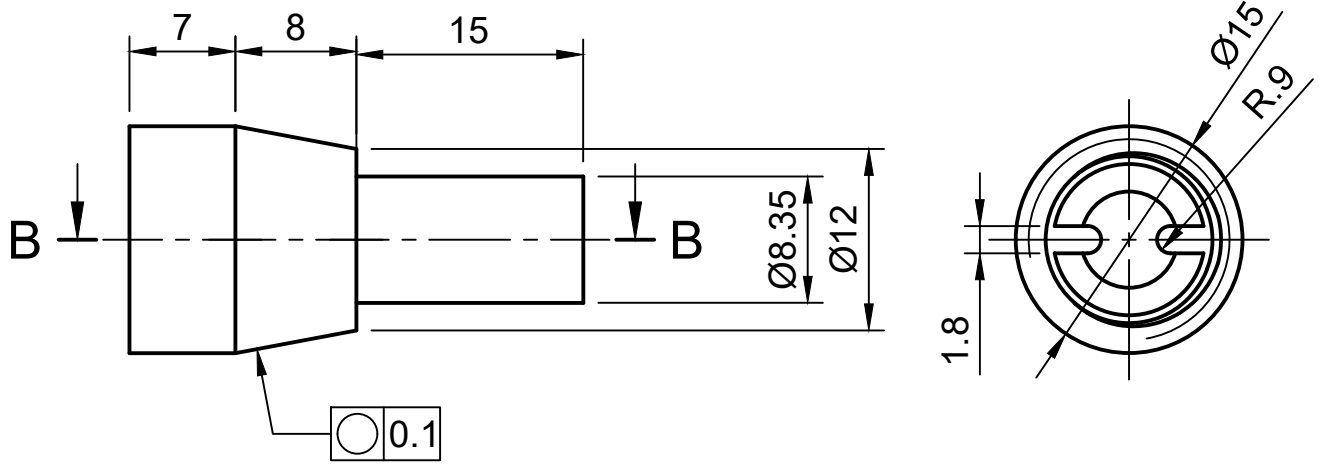

B-B (2:1)

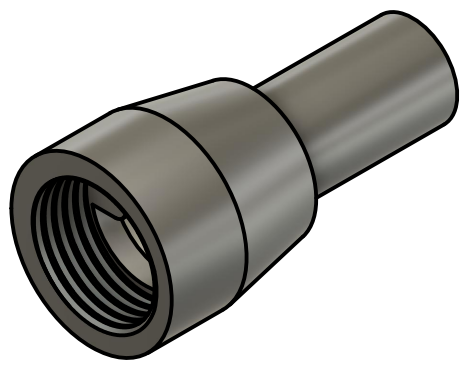
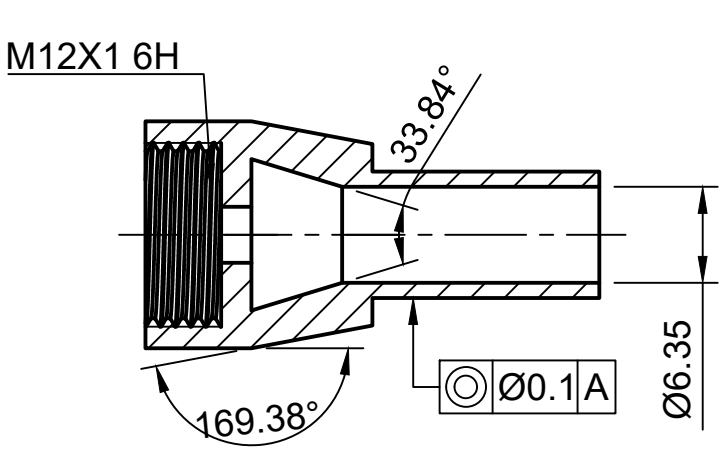

Tolerance 0.1		Weight N/A	316 Stainless Steel		
Date	Name				
Drawn	26/12/2020	José Anguisaca	Bioreactor Sealing Bottom Cap	Scale 2:1	
Checked		Erick Lamiña			
Checked		Kevin Orbea			
Approved		Kevin Taday			
			Code PB002A1	Surface Finish N7	Page 1/1

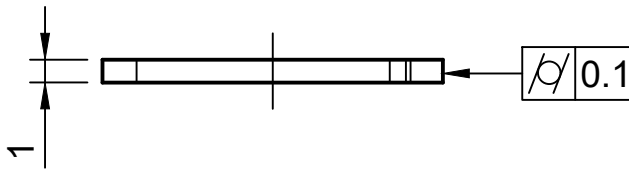
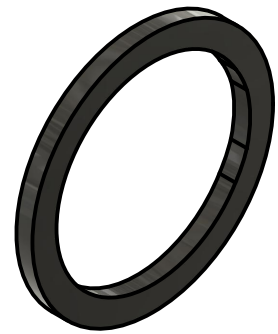
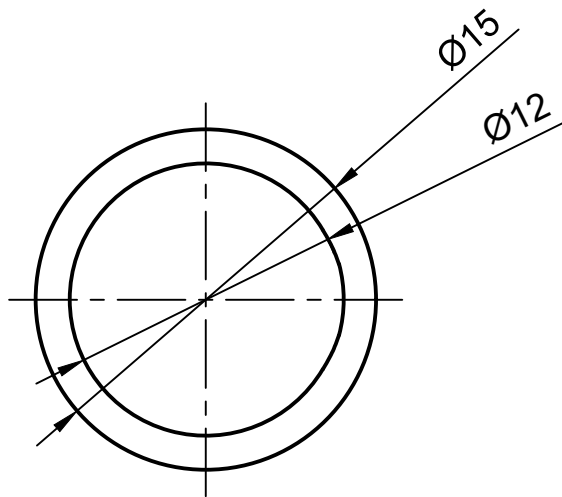

Tolerance 0.1		Weight N/A	316 Stainless Steel		
	Date	Name			
Drawn	26/12/2020	José Anguisaca	Cap Sealing O-ring	Scale 3:1	
Checked		Erick Lamiña			
Checked		Kevin Orbea			
Approved		Kevin Taday			
			Code PB002A2	Surface Finish N7	Page 1/1

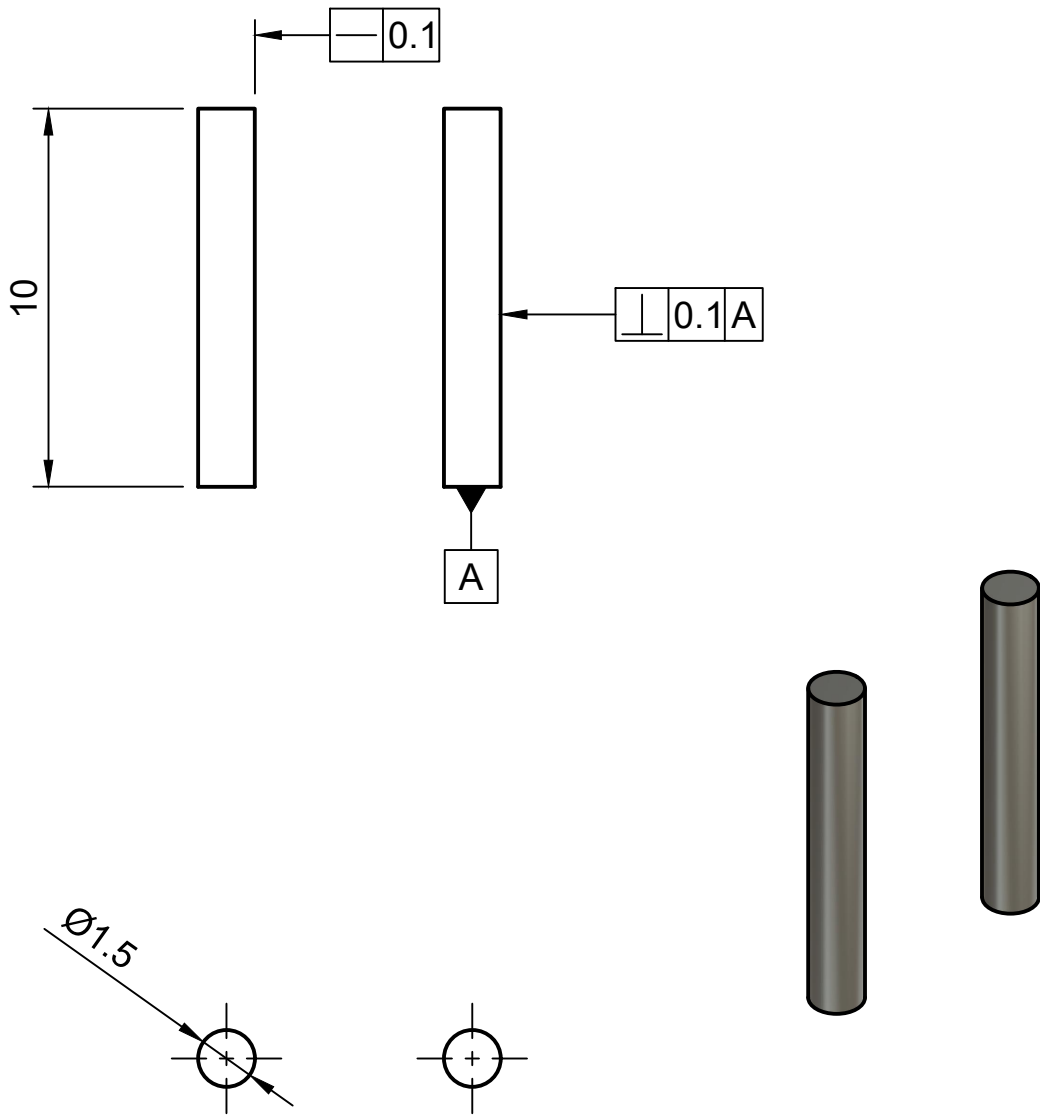

Tolerance 0.1		Weight N/A	316 Stainless Steel		
	Date	Name			
Drawn	26/12/2020	José Anguisaca	Scaffold Support Bars	Scale 5:1	
Checked		Erick Lamiña			
Checked		Kevin Orbea			
Approved		Kevin Taday			
			Code PB002A3	Surface Finish N7	Page 1/1

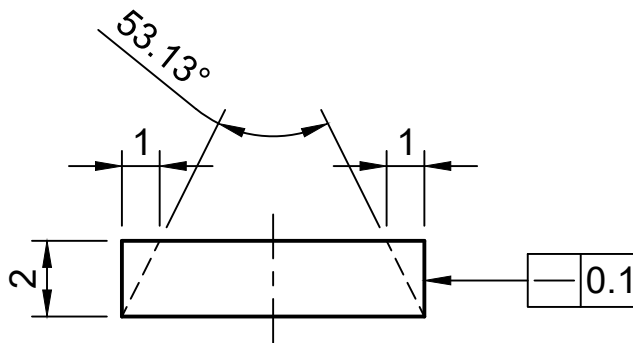
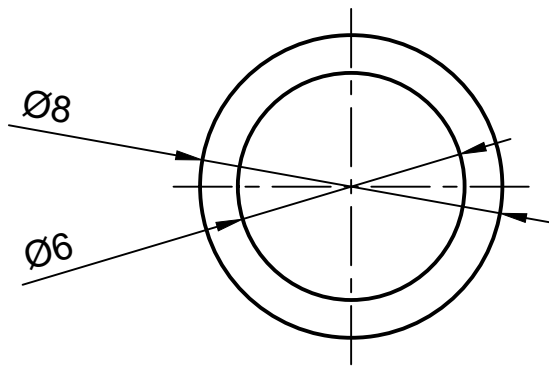

Tolerance 0.1		Weight N/A	316 Stainless Steel		
	Date	Name			
Drawn	26/12/2020	José Anguisaca	Scaffold Support Ring	Scale 5:1	
Checked		Erick Lamiña			
Checked		Kevin Orbea			
Approved		Kevin Taday			
			Code PB002A4	Surface Finish N7	Page 1/1

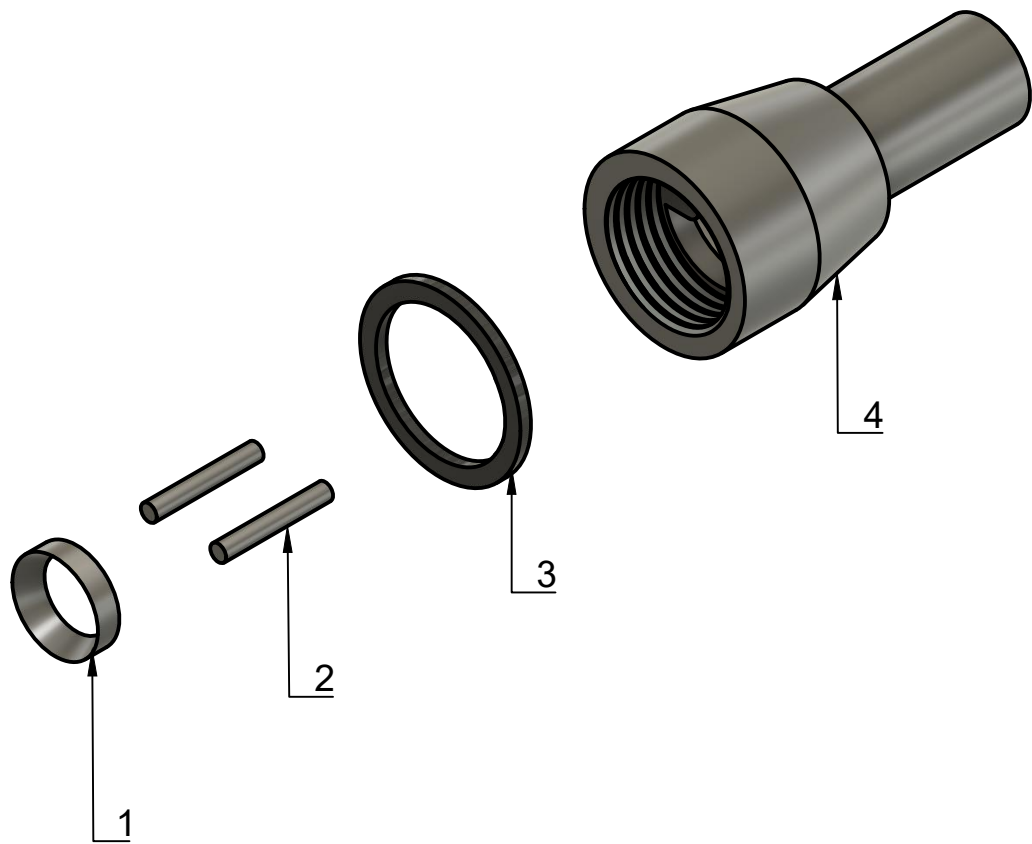

### Bill of Materials

Item	Qty	Part Number	Material
1	1	PB002A4	316 Stainless Steel
2	1	PB002A3	316 Stainless Steel
3	1	PB002A2	316 Stainless Steel
4	1	PB002A1	316 Stainless Steel

Tolerance 0.1		Weight N/A	CAPSTONE		
Date	Name				
Drawn	26/12/2020	José Anguisaca	Bioreactor Sealing Bottom Cap Assembly	Scale 2:1	
Checked		Erick Lamiña			
Checked		Kevin Orbea			
Approved		Kevin Taday			
			Code PB001	Surface Finish N/A	Page 1/1

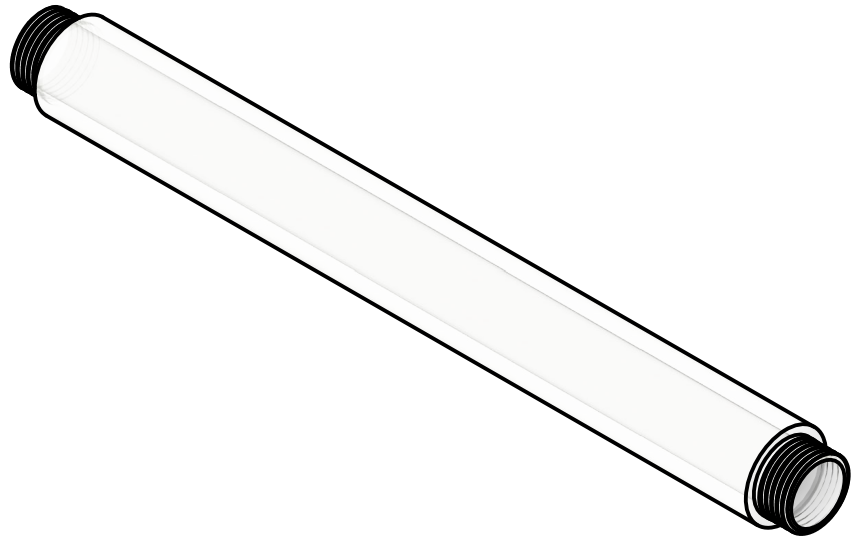
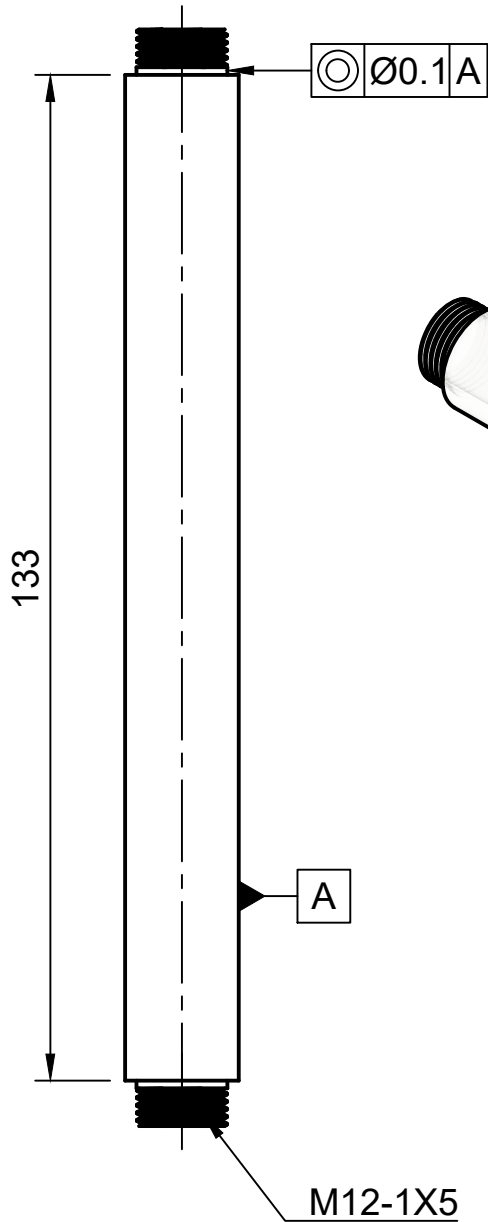
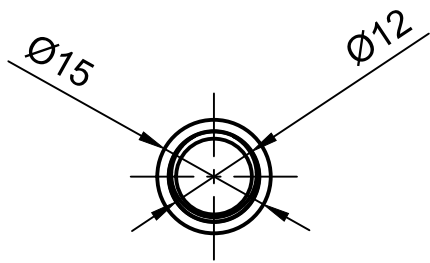

Tolerance 0.1		Weight N/A	Acrylic PMMA		
	Date	Name			
Drawn	26/12/2020	José Anguisaca	Bioreactor Chamber	Scale 1:1	
Checked		Erick Lamiña			
Checked		Kevin Orbea			
Approved		Kevin Taday			
			Code PB003	Surface Finish N/A	Page 1/1

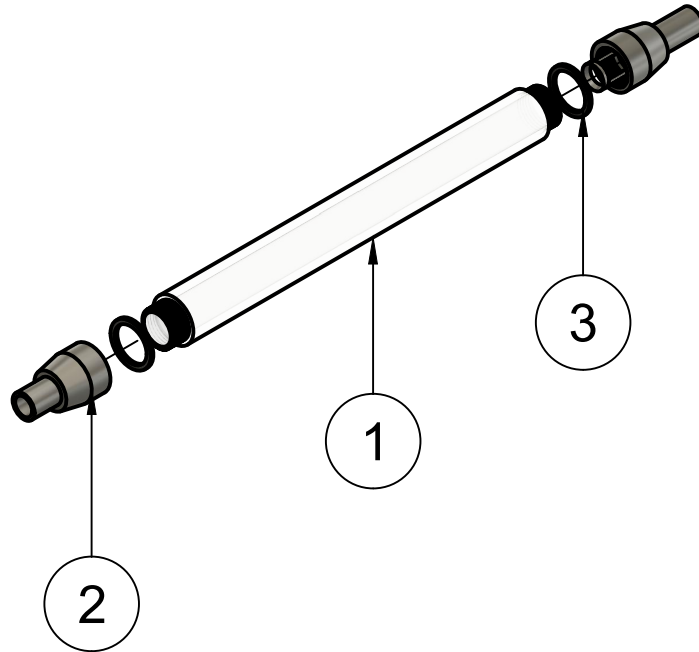

**Bill of Materials**

Item	Qty	Part number	Material
1	1	PB003	Acrylic PMMA
2	1	PB001	316 Stainless Steel
3	1	PBA002	316 Stainless Steel

Tolerance 0.1		Weight N/A	<b>CAPSTONE</b>		
	Date	Name			
Drawn	26/12/2020	José Anguisaca	<b>Bioreactor Chamber Assembly</b>	Scale 1:2	
Checked		Erick Lamiña			
Checked		Kevin Orbea			
Approved		Kevin Taday			
			Code PBA003	Surface Finish N/A	Page 1/1



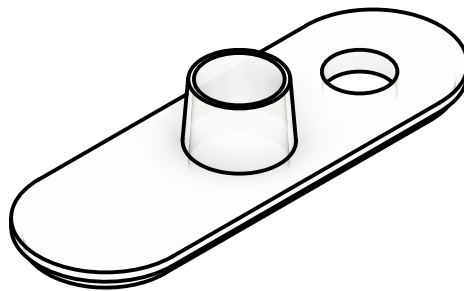
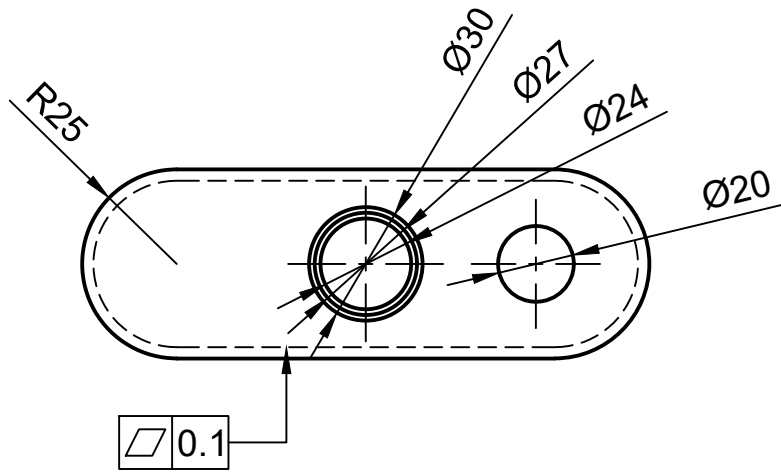
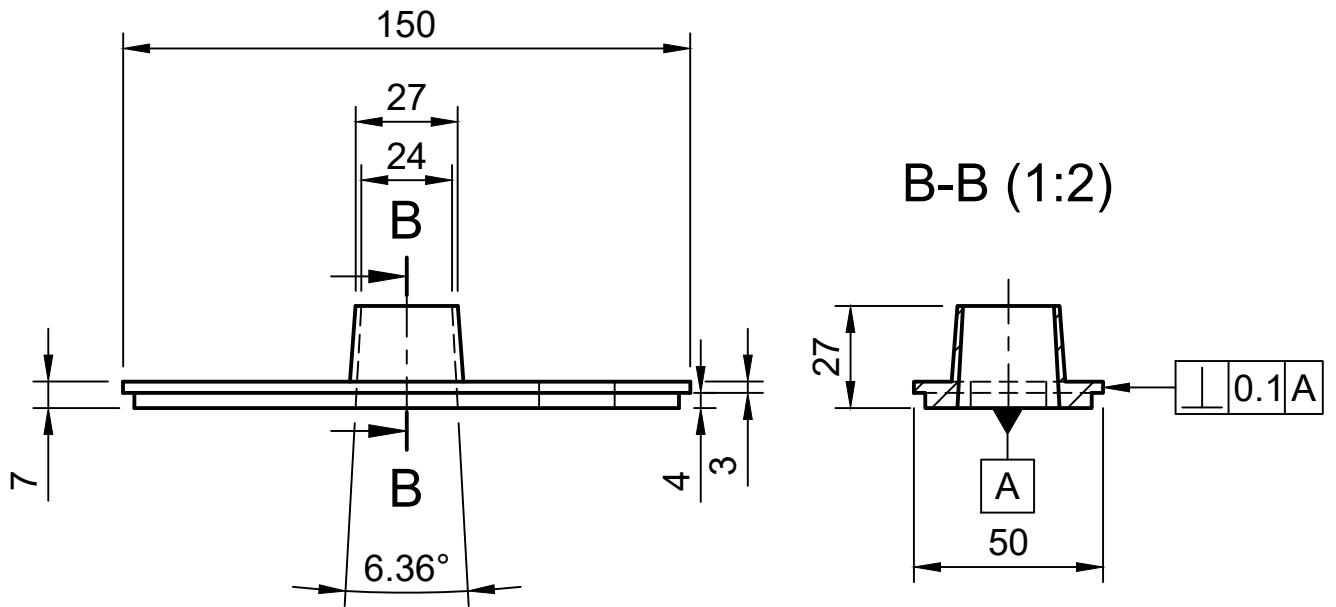

Tolerance 0.1		Weight N/A	Acrylic PMMA		
Date	Name				
Drawn	26/12/2020	José Anguisaca	Medium Reservoir Cap	Scale 1:2	
Checked		Erick Lamiña			
Checked		Kevin Orbea			
Approved		Kevin Taday			
			Code PB004A1	Surface Finish N/A	Page 1/1

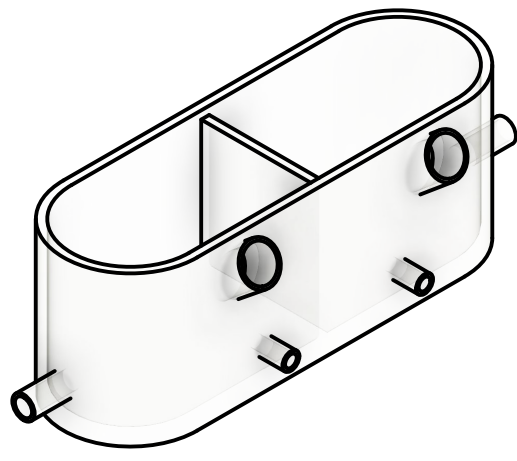
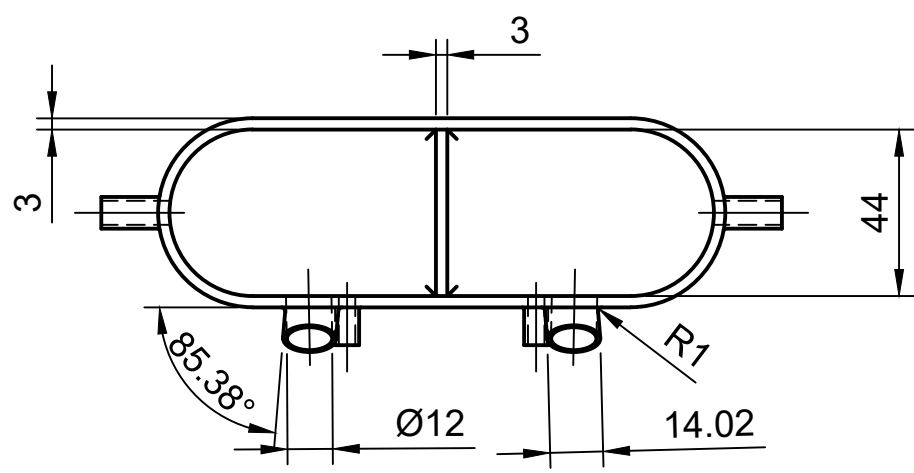
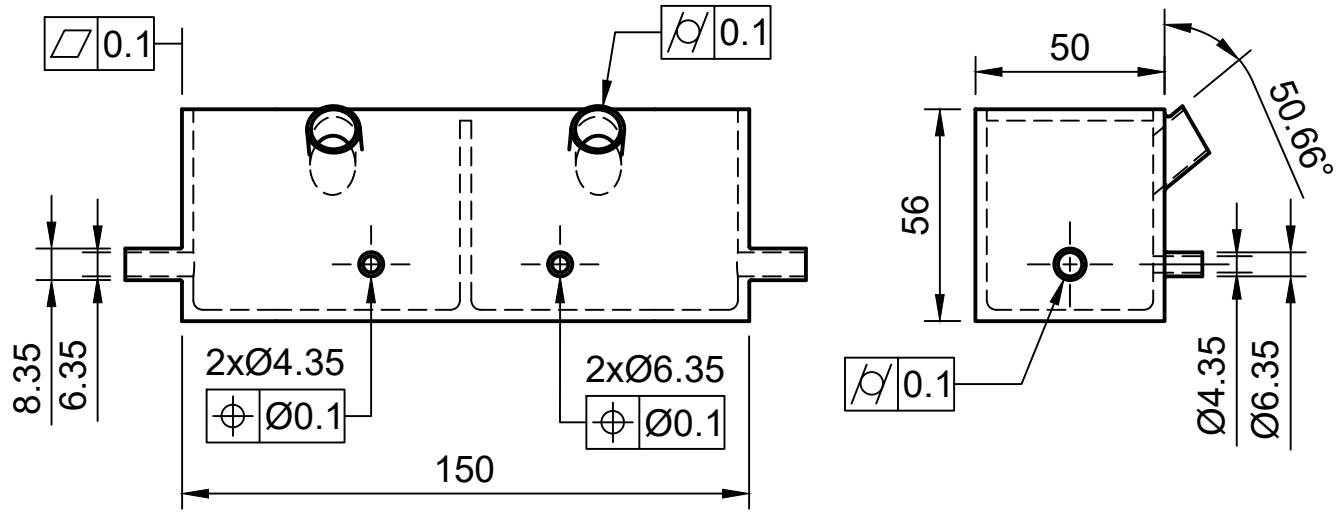

Tolerance 0.1		Weight N/A	Acrylic PMMA		
	Date	Name			
Drawn	26/12/2020	José Anguisaca	Medium Reservoir	Scale 1:2	
Checked		Erick Lamiña			
Checked		Kevin Orbea			
Approved		Kevin Taday			
			Code PB004A2	Surface Finish N/A	Page 1/1

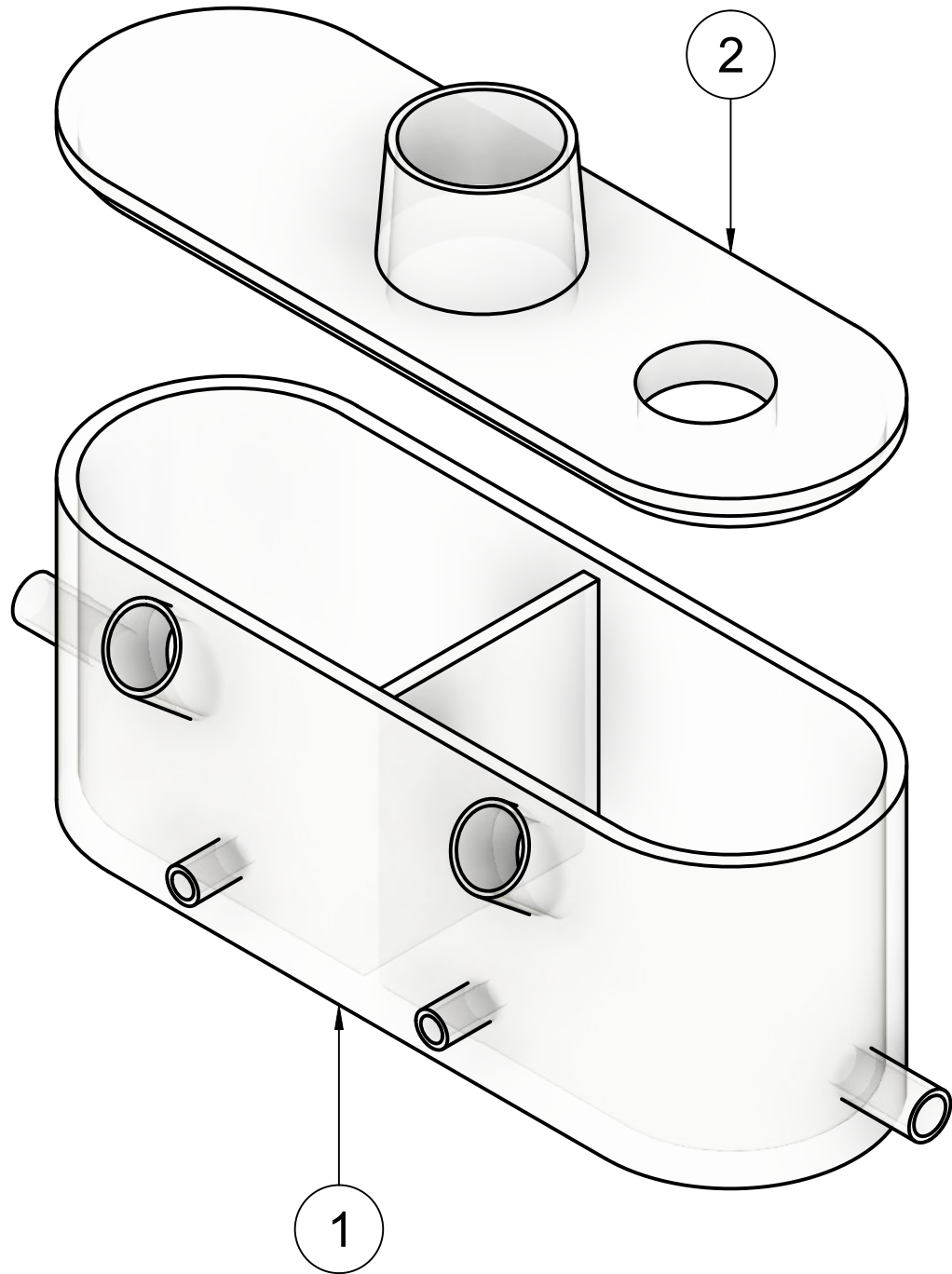

Bill of Materials

Item	Qty	Part Number	Material
1	1	PB004A1	Acrylic PMMA
2	1	PB004A2	Acrylic PMMA

Tolerance 0.1		Weight N/A	CAPSTONE		
Date	Name				
Drawn	26/12/2020	José Anguisaca	Medium Reservoir Assembly	Scale 1:1	
Checked		Erick Lamiña			
Checked		Kevin Orbea			
Approved		Kevin Taday			
			Code PBA004	Surface Finish N/A	Page 1/1

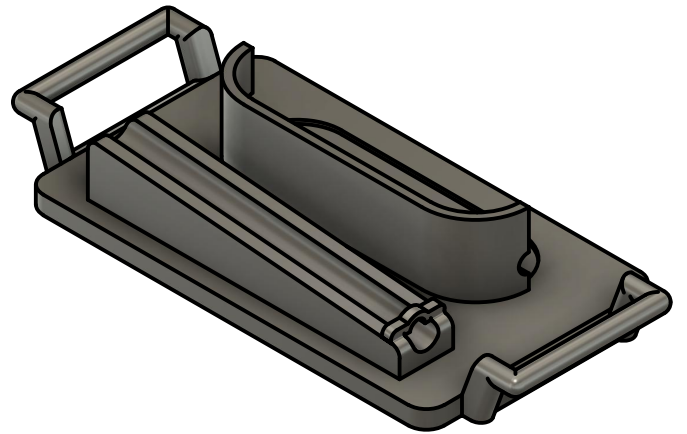
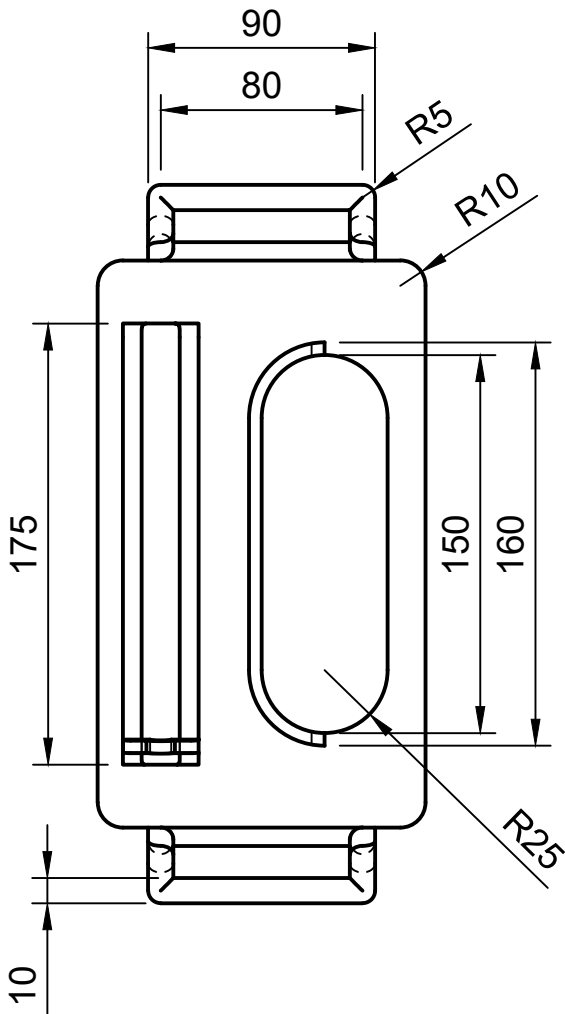
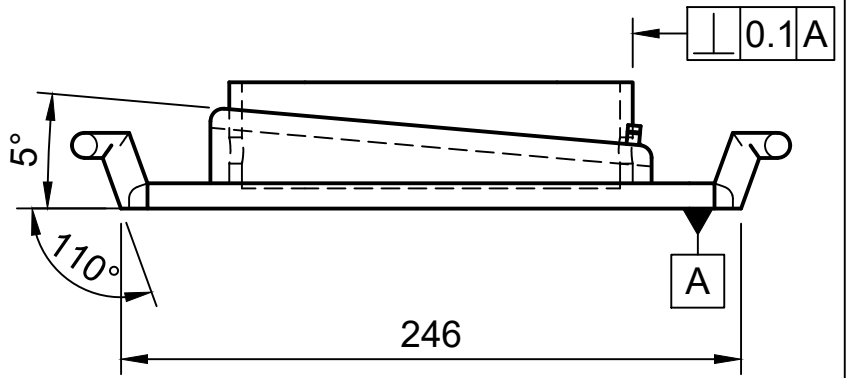
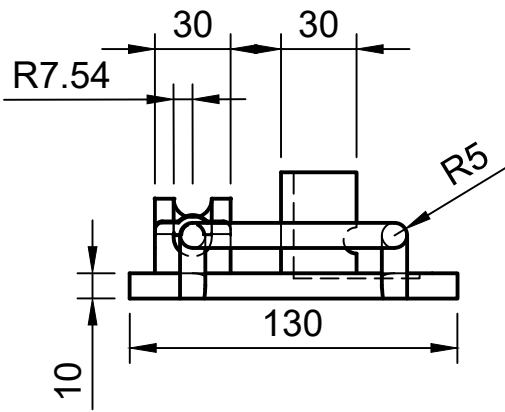

Tolerance 0.1		Weight N/A	PLA		
Date	Name				
Drawn	26/12/2020	José Anguisaca	Tray	Scale 1:3	
Checked		Erick Lamiña			
Checked		Kevin Orbea			
Approved		Kevin Taday			
			Code PB005	Surface Finish N/A	Page 1/1

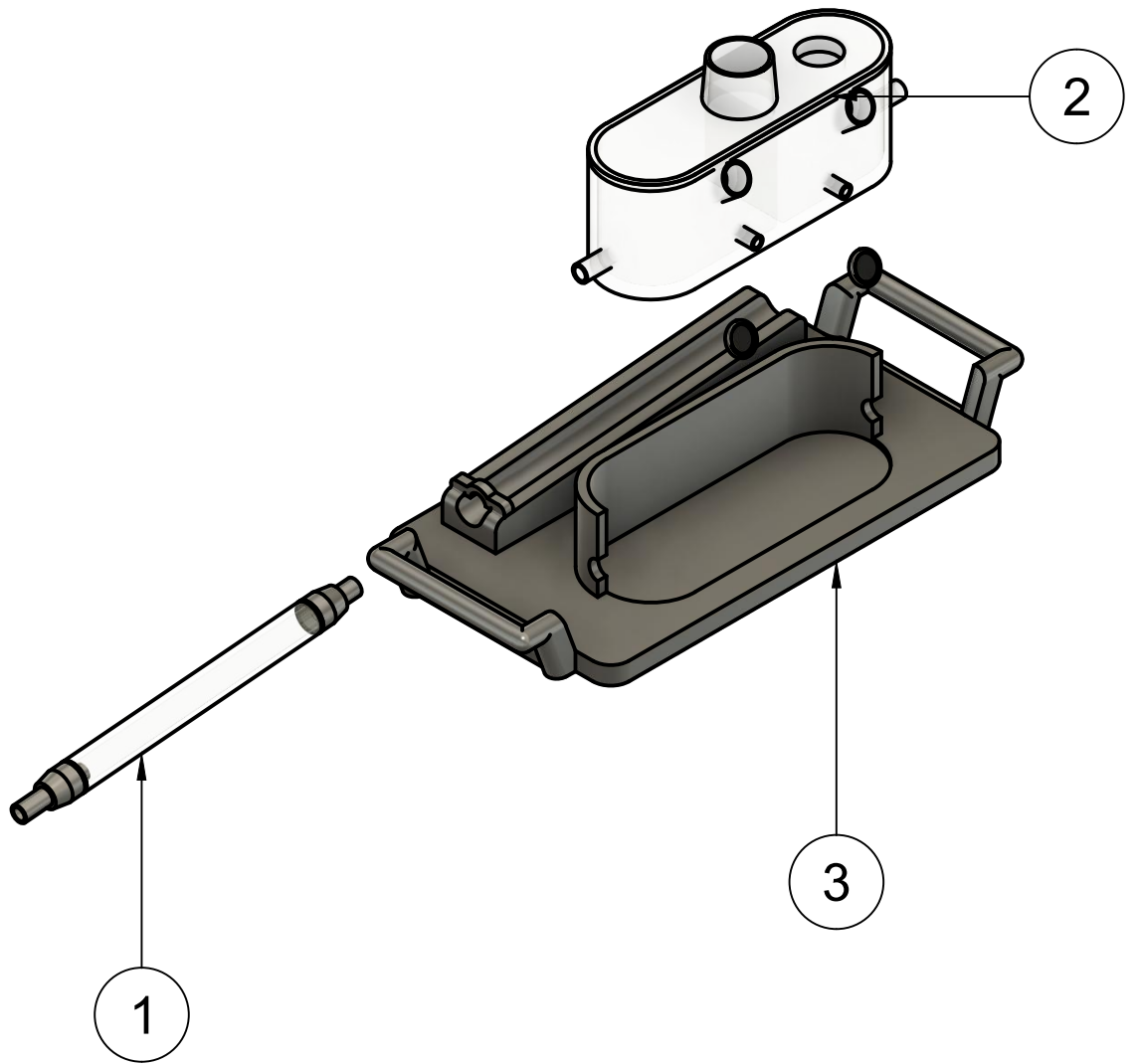

**Bill of Materials**

Item	Qty	Party Number	Material
1	1	PBA002	Acrylic PMMA / 316 SS
2	1	PBA004	Acrylic PMMA
3	1	PB005	PLA

Tolerance 0.1	Weight N/A	<b>CAPSTONE</b>	
	Date		
Drawn	26/12/2020	José Anguisaca	<b>Bioreactor</b>  Scale 1:3
Checked		Erick Lamiña	
Checked		Kevin Orbea	
Approved		Kevin Taday	



Code  
PBA006

Surface Finish  
N/A

Page  
1/1

Appendix C

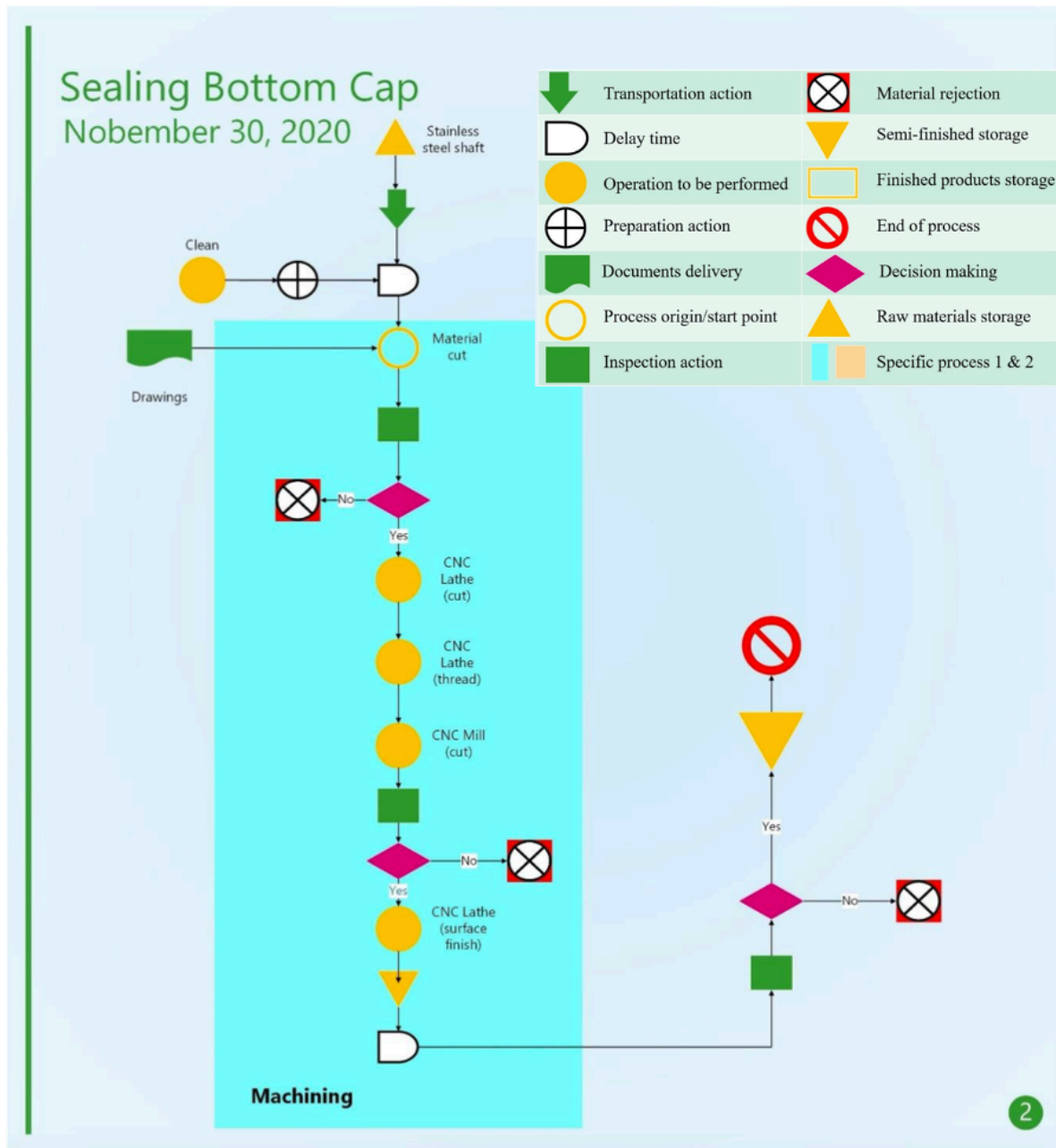

# Support Bars

November 30, 2020

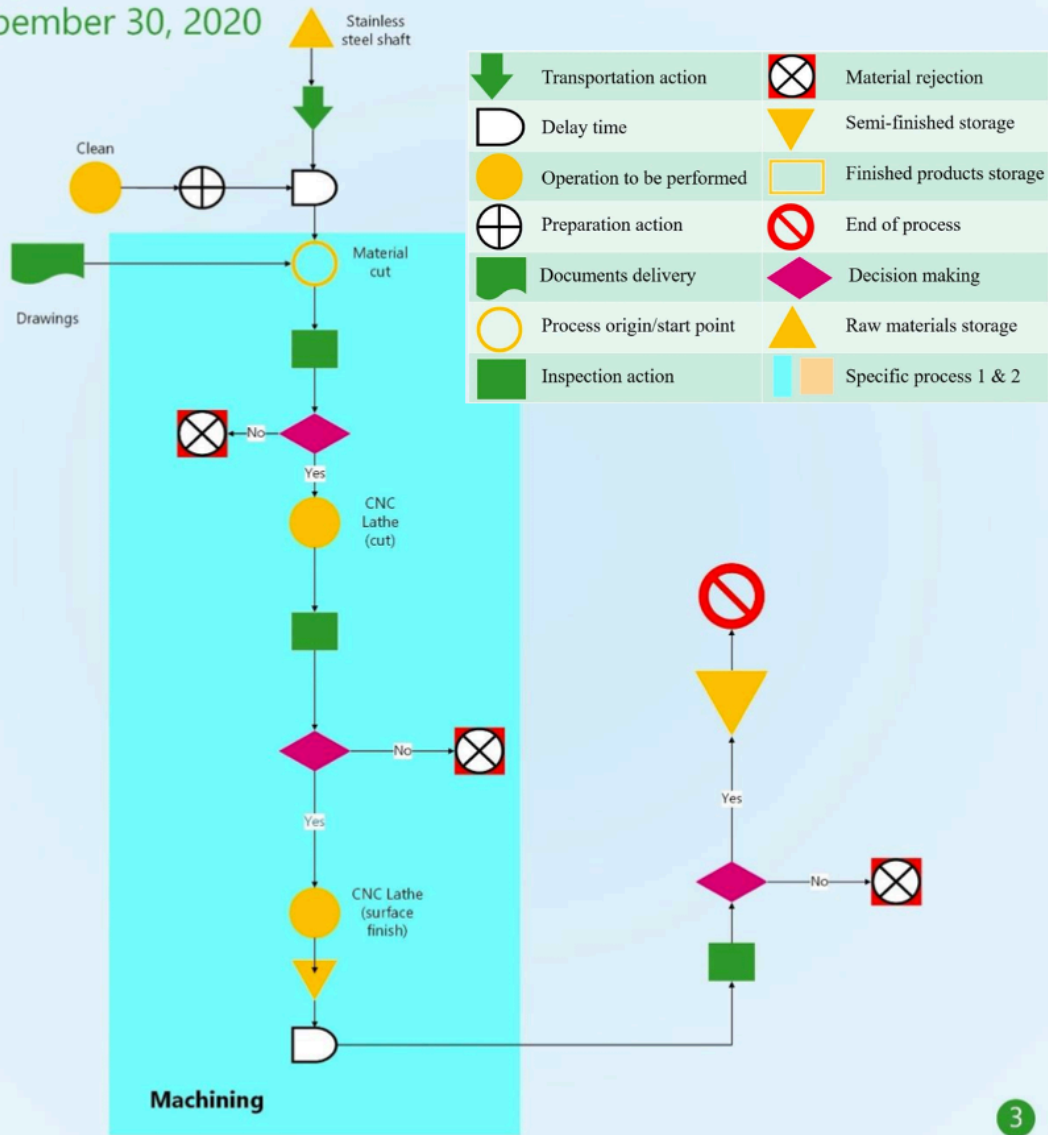

# Support Ring

November 30, 2020

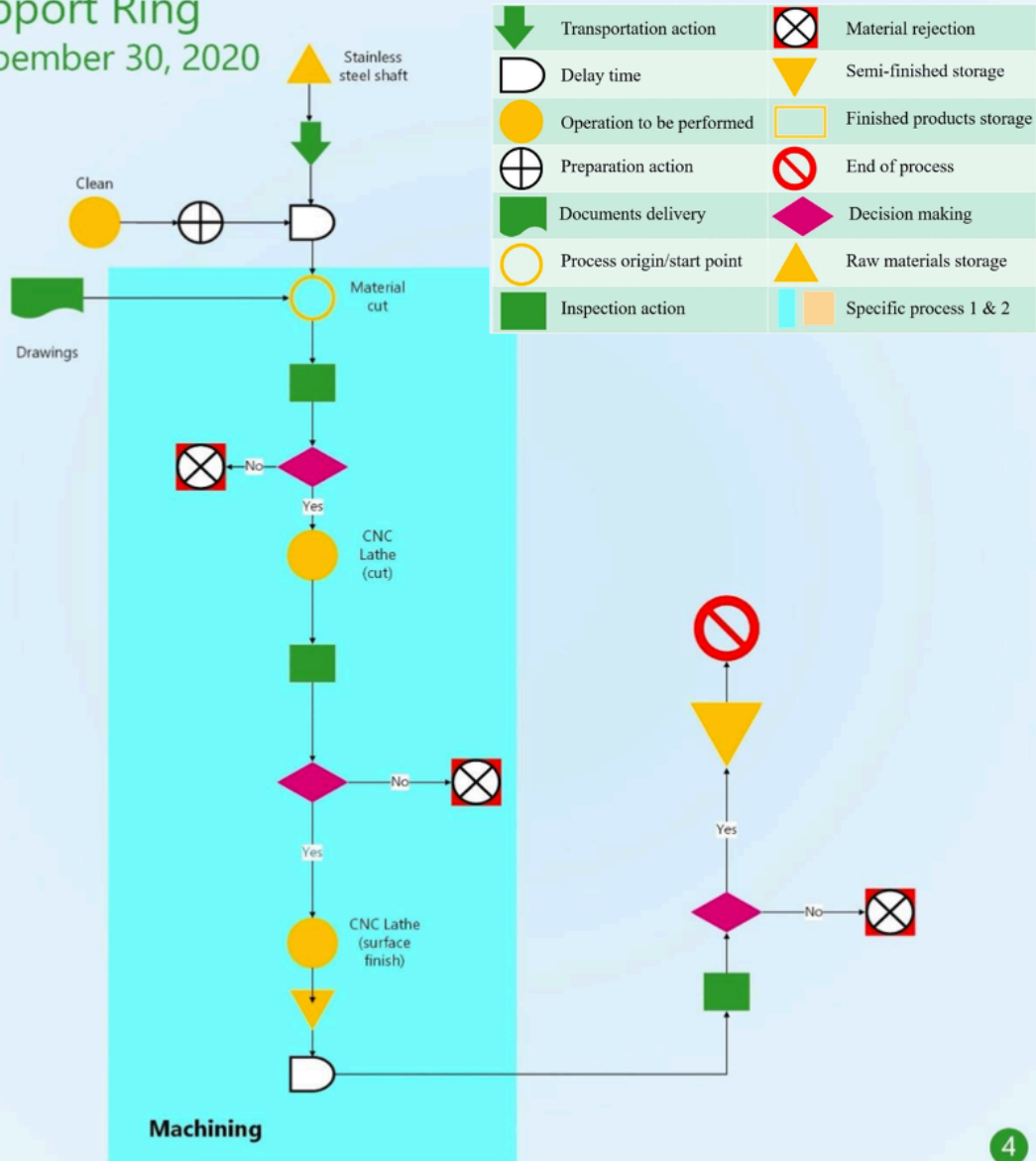



# Bottom Cap Assembly

November 30, 2020

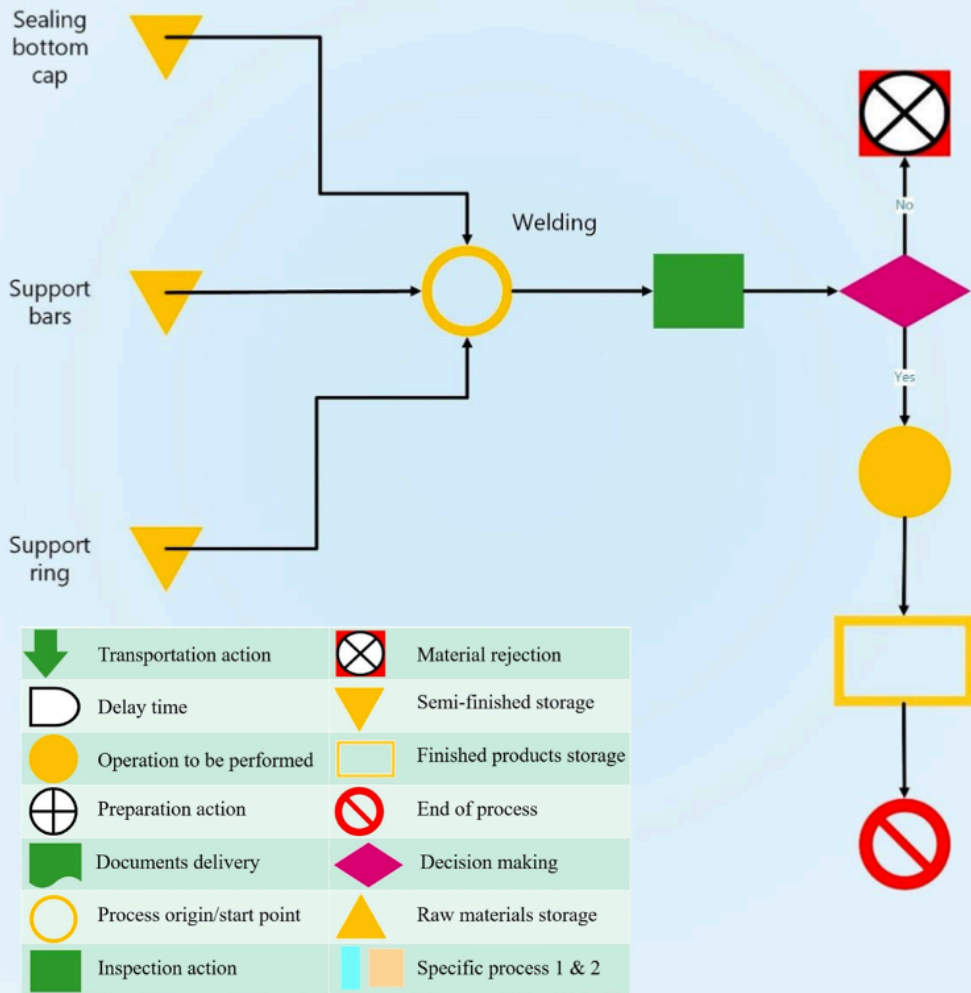

# Bioreactor Chamber

November 30, 2020

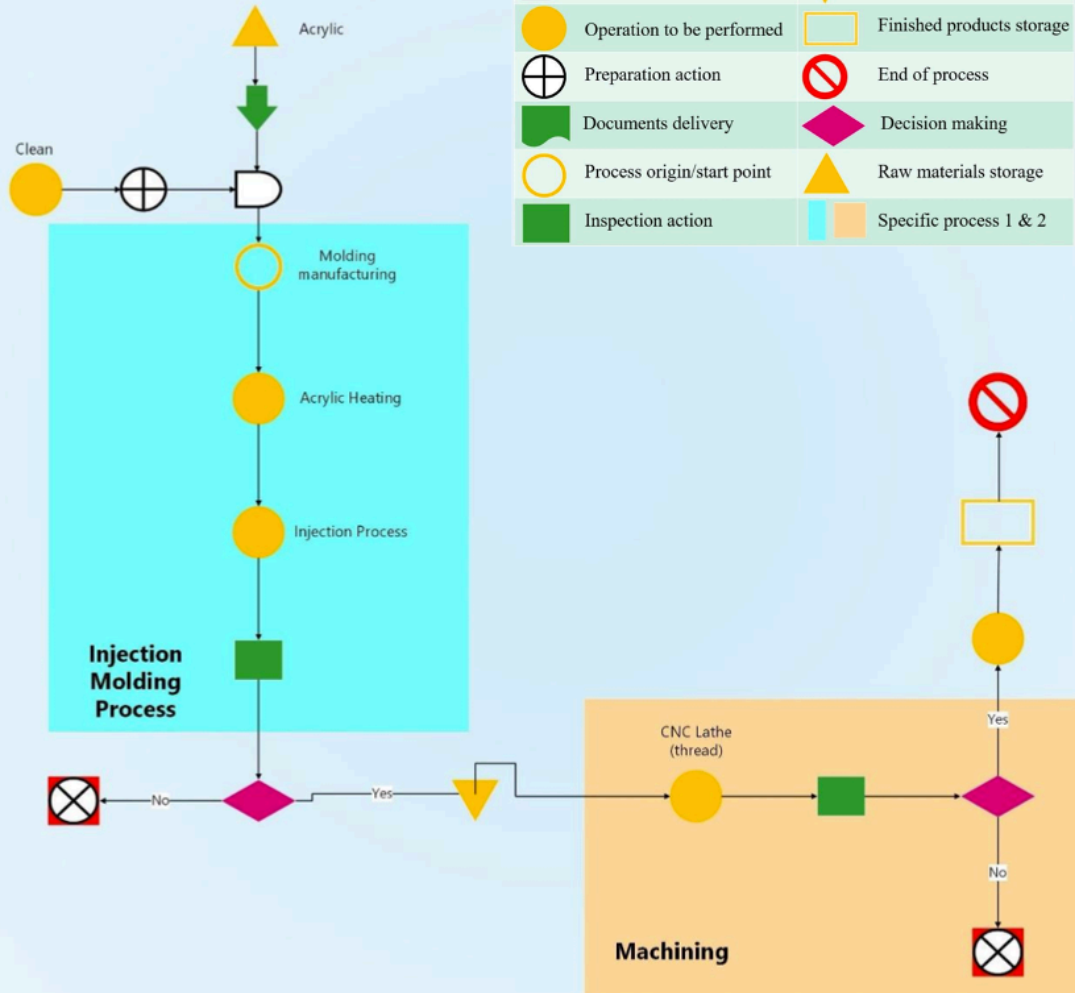

# Reservoir Cap

November 30, 2020

	Transportation action		Material rejection
	Delay time		Semi-finished storage
	Operation to be performed		Finished products storage
	Preparation action		End of process
	Documents delivery		Decision making
	Process origin/start point		Raw materials storage
	Inspection action		Specific process 1 & 2

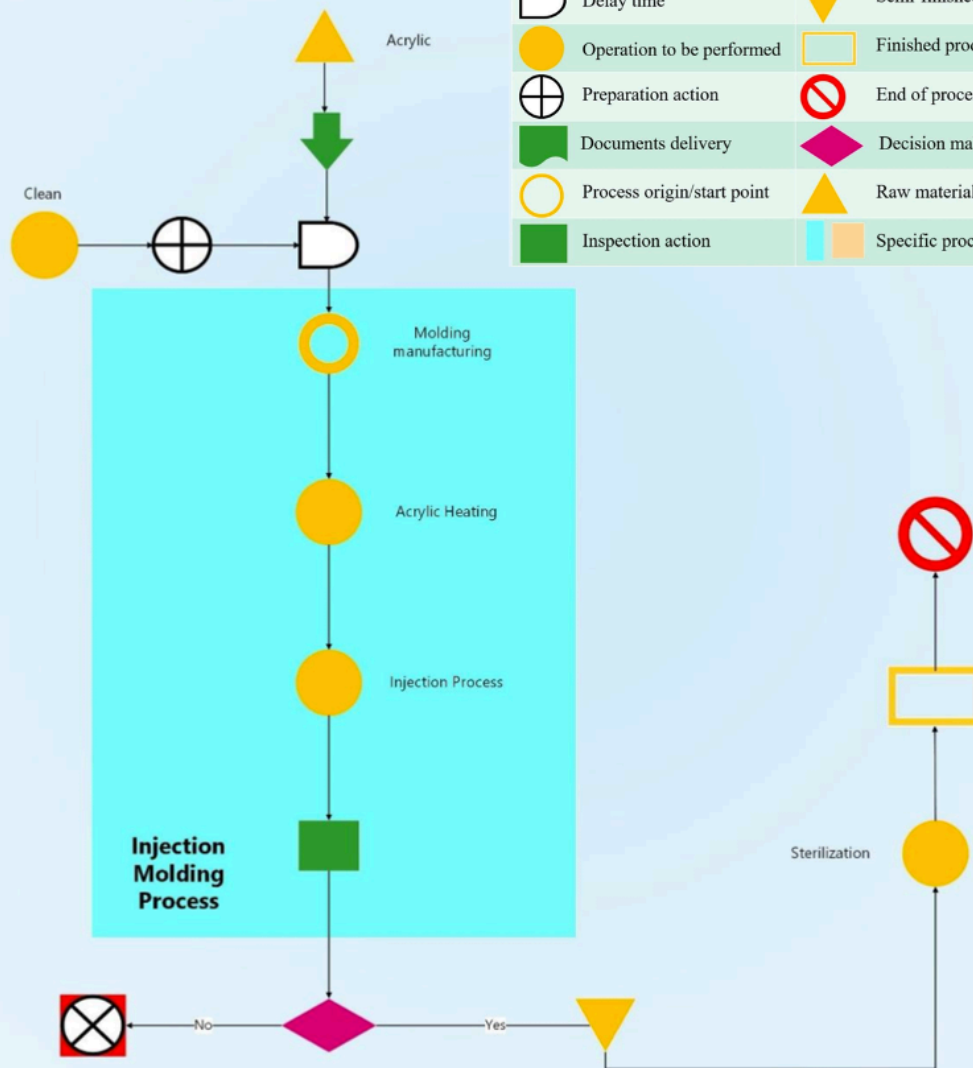

Reservoir  
November 30, 2020

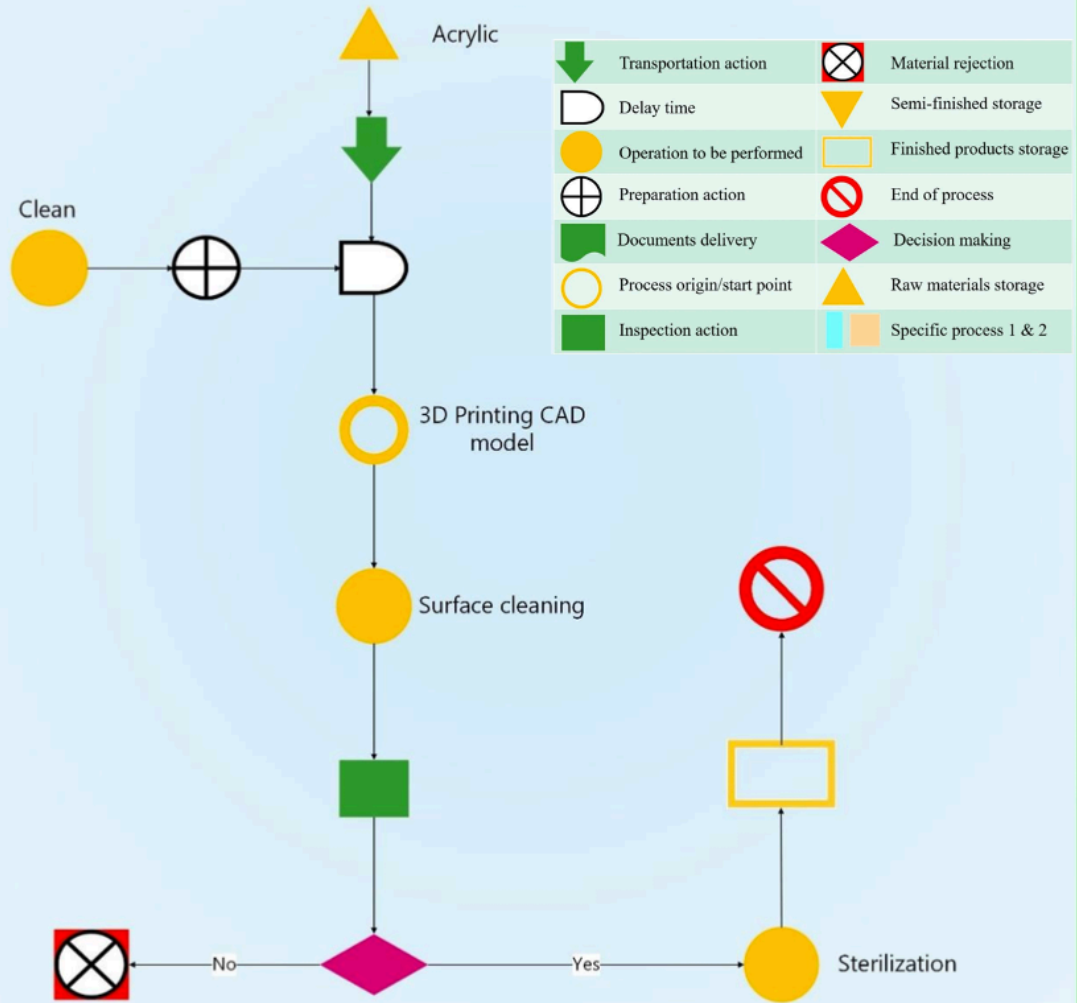

# System Tray

November 30, 2020

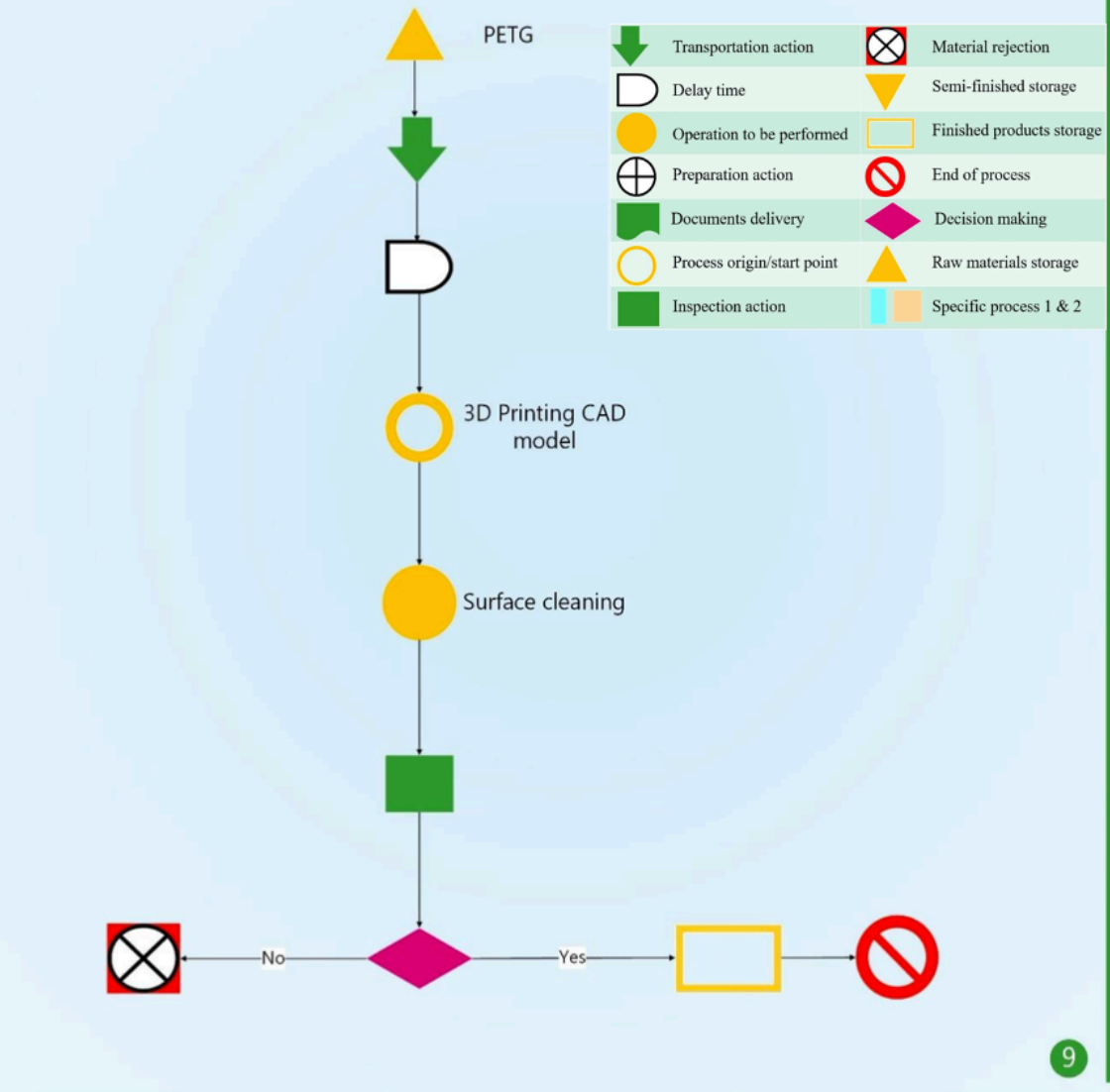

## Appendix D

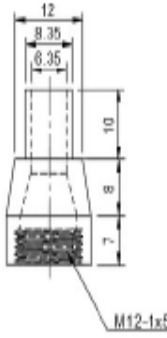

Manufacturing Plan							
Part	1	Description	Bioreactor Sealing Top Cap	Drawing	PB001	Quantity	2
Material	316 Stainless Steel	Person in charge	Kevin Taday				
N°	Activities	Description		Tools	Date	Manufacturing Time	
1	Cut	Cutting raw material into more manageable pieces		Metal band saw machine	01/01/2021	30 min	
2	Drill	Drill small hole through out the material		CNC lathe, drill bit	01/01/2021	30 min	
3	Roughing	Roughing the shaft into the desired shape		CNC lathe, blade	01/01/2021	60 min	
4	Threading	Make specify threads using a tap		CNC Lathe, tap drill	01/01/2020	20 min	
						Cost	\$35

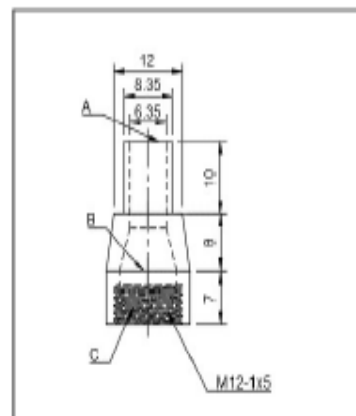

Performance indicators						
Code	Dimensions [mm]	Tolerances [mm]	Equipment	Person in charge	Check mark	Notes
A	6.35	±0.5	Digital Caliper	José Anguisaca		
B	10	±0.5	Digital Caliper	José Anguisaca		
C	M12-1X5	±0.5	Digital Caliper	José Anguisaca		

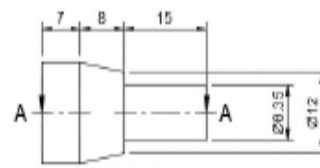

A-A (2:1)

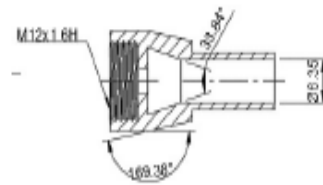

Manufacturing Plan							
Part	2	Description	Bioreactor Sealing Bottom Cap	Drawing	PB002	Quantity	2
Material	316 Stainless Steel	Person in charge	Kevin Orbea				
N°	Activities	Description	Tools	Date	Manufacturing Time		
1	Cut	Cutting raw material into more manageable pieces	Metal band saw machine	04/01/2021	30 min		
2	Drill	Drill small hole through out the material	CNC lathe, drill bit	04/01/2021	30 min		
3	Roughing	Roughing the shaft into the desired shape	CNC lathe, blade	04/01/2021	60 min		
4	Threading	Make specify threads using a tap	CNC Lathe, tap drill	04/01/2021	20 min		
Scaffold support bars							
5	Cut	Cutting raw material into more manageable pieces	Metal band saw machine	04/01/2021	10 min		
6	Roughing	Roughing the shaft into the desired diameter	CNC lathe, blade	04/01/2021	30 min		
Scaffold support ring							
7	Cut	Cutting raw material into more manageable pieces	Metal band saw machine	04/01/2021	10 min		
8	Drill	Drill small hole through out the material	CNC lathe, drill bit	04/01/2021	15 min		
9	Roughing	Roughing the shaft into the desired shape (cone)	CNC lathe, blade	04/01/2021	20 min		
Assembly							
10	Welding	Weld together to make a single piece	Handheld laser welder	04/01/2021	10 min		
						Cost	\$45

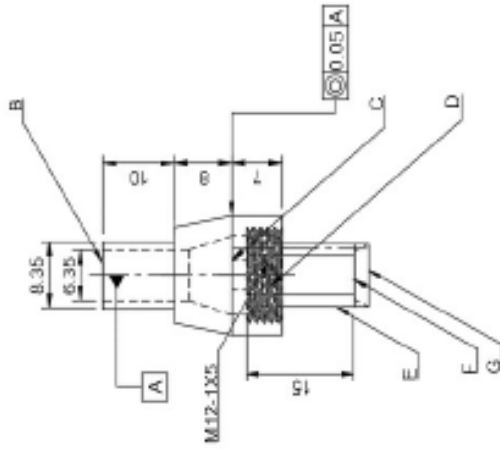

**Performance indicators**

Code	Dimensions [mm]	Tolerances [mm]	Equipment	Person in charge	Check mark	Notes
B	6.35	±0.5	Digital Caliper	Erick Lamiña		
C	10	±0.5	Digital Caliper	Erick Lamiña		
D	M12-1X5	±0.5	Digital Caliper	Erick Lamiña		
E	1.5	±0.5	Micrometer	Erick Lamiña		
F	5	±0.5	Digital Caliper	Erick Lamiña		
G	8	±0.5	Digital Caliper	Erick Lamiña		



Manufacturing Plan						
Part	3	Description	Bioreactor Chamber	Drawing	PB003	Quantity
Material	Acrylic PMMA	Person in charge	Erick Lamiña			
N°	Activities	Description	Tools			
1	Mold setup	Create a mold that satisfy the desing dimentionions	Steel Molds			
2	Injection mold	Injecting molten acrylic into the steel mold	Hidraulyc Press			
3	Cooling and release	Let the molten acrylic cool in the steel mold until is solid enough to be ejected	Steel Mold, Compressed Air			
4	Threading	Make specify threads using a tap	CNC Lathe, tap drill			
					Date	Manufacturing Time
					07/01/2021	24 h
					07/01/2021	15 min
					07/01/2021	20 min
					07/01/2020	20 min
					Cost	\$120

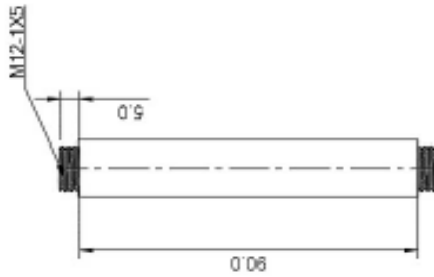

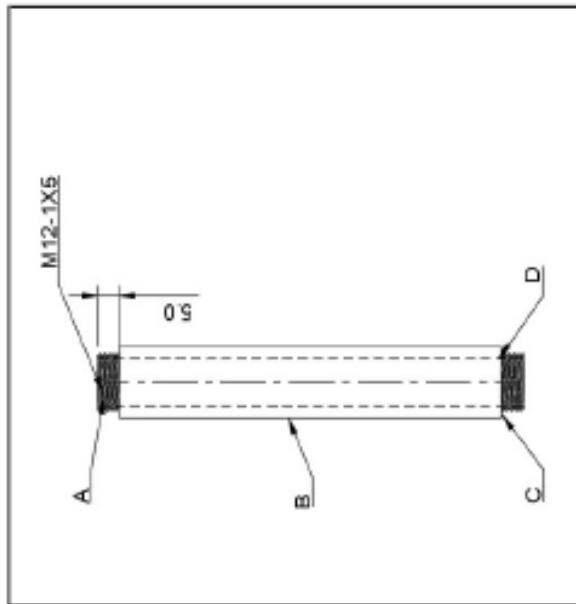

### Performance indicators

Code	Dimensions [mm]	Tolerances [mm]	Equipment	Person in charge	Check mark	Notes
A	M12-1X5	±0.5	Digital Caliper	Kevin Orbea		
B	90	±0.5	Digital Caliper	Kevin Orbea		
C	15	±0.5	Digital Caliper	Kevin Orbea		
D	10	±0.5	Digital Caliper	Kevin Orbea		

Part	4	Description	Reservoir Cap	Drawing	PB004	Quantity	2
Material	Acrylic PMMA	Person in charge	José Anguisaca				
N°	Activities	Description		Tools	Date	Manufacturing Time	
1	Mold setup	Create a mold that satisfy the desing dimentionns		Steel Molds	10/01/2021	24 h	
2	Injection mold	Injecting molten acrylic into the steel mold		Hidraulyc Press	10/01/2021	15 min	
3	Cooling and release	Let the molten acrylic cool in the steel mold until is solid enough to be ejected		Steel Mold, Compressed Air	10/01/2021	20 min	
					Cost	\$150	

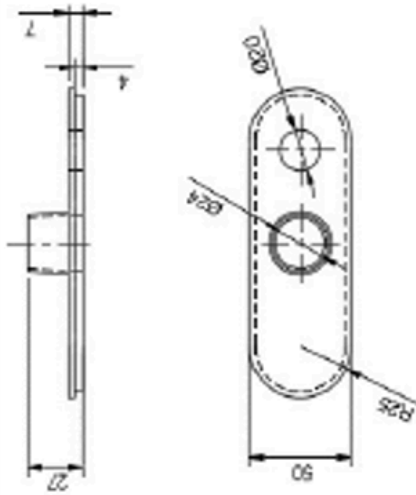

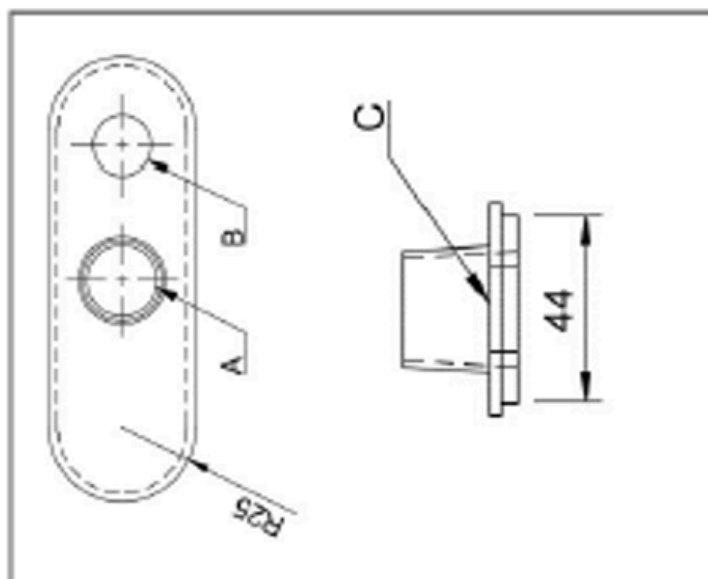
**Performance indicators**

Code	Dimensions [mm]	Tolerances [mm]	Equipment	Person in charge	Check mark	Notes
A	24	$\pm 0.5$	Digital Caliper	Kevin Taday		
B	20	$\pm 0.5$	Digital Caliper	Kevin Taday		
C	50	$\pm 0.5$	Digital Caliper	Kevin Taday		

Manufacturing Plan						
Part	5	Description	Reservoir	Drawing	P8005	Quantity
Material	Acrylic PMMA	Person in charge	Kevin Taday			
N°	Activities	Description		Tools	Date	Manufacturing Time
1	CAD	Create a 3D CAD		Fusion 360	13/01/2021	180 min
2	3D Printing	Print in acrylic the specific 3D CAD		3D Printer	13/01/2021	120 min
3	Remove the material excess	Remove the material excess to have smooth surface		Sandpaper	13/01/2021	20 min
					Cost	\$100

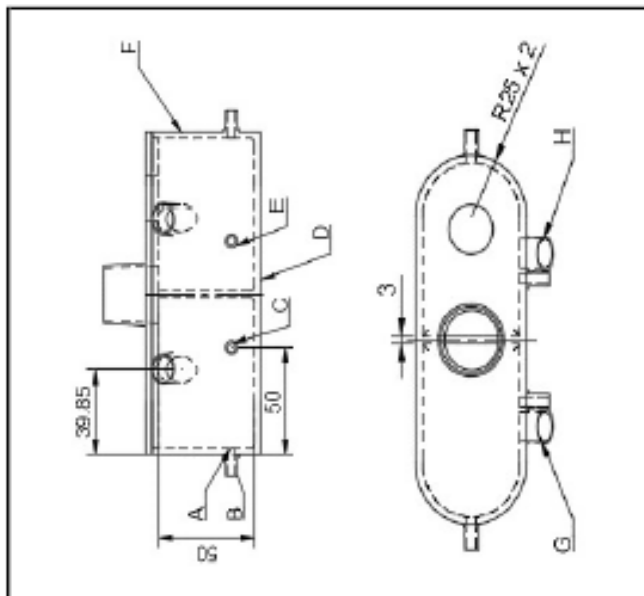

### Performance indicators

Code	Dimensions [mm]	Tolerances [mm]	Equipment	Person in charge	Check mark	Notes
A	4.35X2	±0.5	Digital Caliper	José Anguisaca		
B	6.35X2	±0.5	Digital Caliper	José Anguisaca		
C	4.35X2	±0.5	Digital Caliper	José Anguisaca		
E	6.35X2	±0.5	Digital Caliper	José Anguisaca		
F	56	±0.5	Digital Caliper	José Anguisaca		
G	14.02	±0.5	Digital Caliper	José Anguisaca		
H	12	±0.5	Digital Caliper	José Anguisaca		

Part	6	Description	System Tray	Drawing	PB006	Quantity	2
Material	PLA	Person in charge	Kevin Orbea				
N°	Activities	Description					
1	CAD	Create a 3D CAD					
2	3D Printing	Print in PLA the specific 3D CAD					
3	Remove the material excess	Remove the material excess to have smooth surface					
					Tools	Date	Manufacturing Time
					Fusion 360	16/01/2021	180 min
					3D Printer	16/01/2021	120 min
					Sandpaper	16/01/2021	20 min
						Cost	\$80

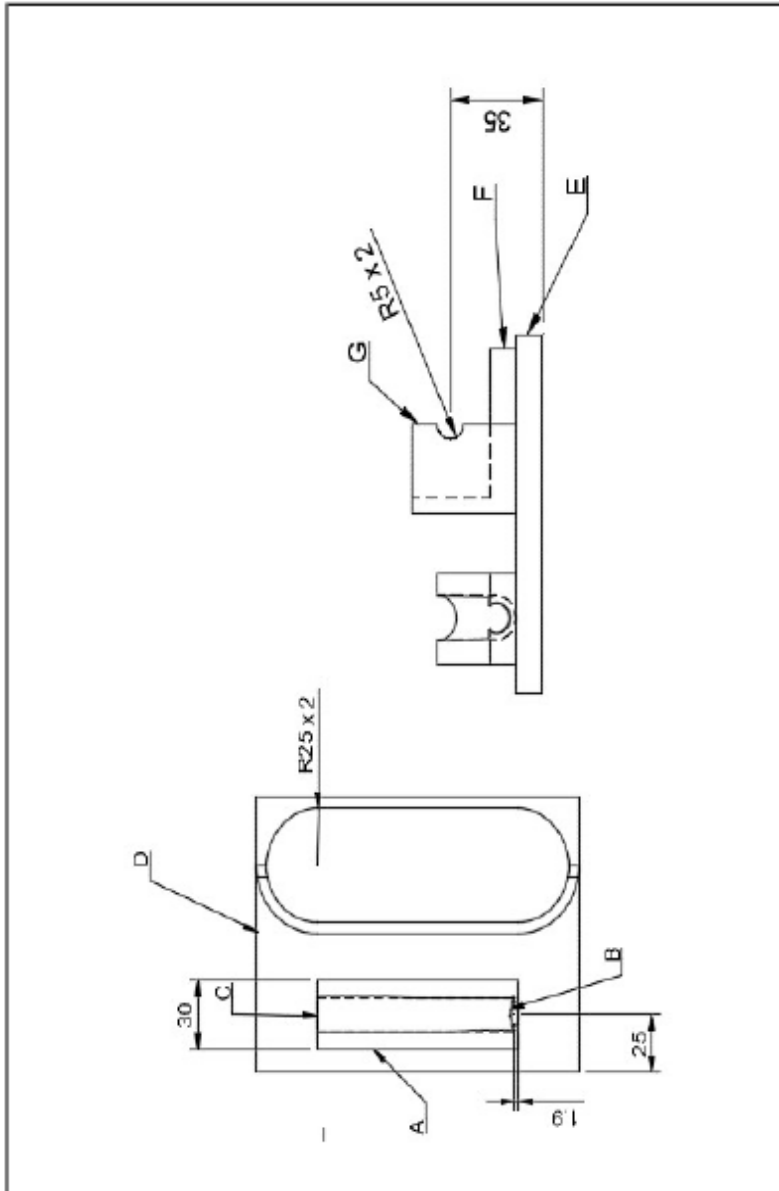

**Performance indicators**

Code	Dimensions [mm]	Tolerances [mm]	Equipment	Person in charge	Check mark	Notes
A	100	±0.5	Digital Caliper	Erick Lamiña		
B	10	±0.5	Digital Caliper	Erick Lamiña		
C	15	±0.5	Digital Caliper	Erick Lamiña		
E	10	±0.5	Digital Caliper	Erick Lamiña		
F	20	±0.5	Digital Caliper	Erick Lamiña		
G	50	±0.5	Digital Caliper	Erick Lamiña		



## Appendix E

### Arduino Codes

#### First Electronic System Simulation Code Proteus with Cases of time

```

#include <Servo.h>

#include <LiquidCrystal.h>

Servo servo_test;

LiquidCrystal lcd(13, 12, 11, 10, 9, 8);

volatile float flow_frequency; // Measures flow sensor pulses

float Q;

float Q_1;

float Q_target;

float flowsensor = 2; // Sensor Input for Flowmeter

double currentTime;

double zeroTime;

double cloopTime;

int angle=0 ; //Initiation of the servo

float Q_position_target_angle;

float Q_servo;

void flow () // Interrupt function

{

    flow_frequency++;

}

void setup()

{

```

```

pinMode(flowsensor, INPUT);

digitalWrite(flowsensor, HIGH); // Optional Internal Pull-Up

lcd.begin(16, 2);

attachInterrupt(digitalPinToInterrupt(flowsensor), flow, RISING); // Setup Interrupt

lcd.clear();

lcd.setCursor(0,0);

lcd.print("BIOREACTOR");

lcd.setCursor(0,1);

lcd.print("MEDIUM FLOWRATE");

currentTime = millis();

zeroTime=millis();

cloopTime = currentTime;

servo_test.attach(7); // pinsignal for servomotor
}

void loop ()
{
    currentTime = millis();

    ////////////////Use for Proteus Simulation different types of frequencies at different times

    if(currentTime-zeroTime<=2000){

        flow_frequency=0.003;

    }

    else if (currentTime-zeroTime<=6000){

```

```

flow_frequency=0.6375;
}

else if (currentTime-zeroTime<=7000){
flow_frequency=0.4;
}

else if (currentTime-zeroTime<=9000){
flow_frequency=0.225;
}
else {
zeroTime=millis();
//currentTime = millis();
}

//////////Range of values of flow_frequency for our peristaltic pump (0.003-0.6375)

// Every second, calculate and print ml/min
if(currentTime >= (cloopTime + 1000))
{
cloopTime = currentTime; // Updates cloopTime

if(flow_frequency != 0){
//Pulse frequency (Hz) = K * Q, Where K is the value from the type of Flowmeter in this
case K=7.5
Q = ((flow_frequency / 7.5)*1000); // Q = flowrate in mL/min

```

```

lcd.clear();

lcd.setCursor(0,0);

lcd.print("FlowRate:");

lcd.setCursor(0,1);

lcd.print(Q);

lcd.print("ml/min");

Q_1=Q*100; //To have decimal values to the map function

////////// change for use of waterflowmeter or flow change in time

Q_servo=map(Q_1,0.4,85,0,180); //*****pump range for Proteus time SIMULATION
(0.4-85)ml/min

Q_servo=Q_servo/100;

Q_position_target_angle=63.52; //*****target of Flowmeter Q=30ml/min for Proteus
time SIMULATION

if(Q_servo < Q_position_target_angle){
  for(Q_servo; Q_servo < Q_position_target_angle ; Q_servo += 1){
    if(Q_servo == Q_position_target_angle)break;
    servo_test.write(Q_servo);
    delay(50);
  }
}

else if(Q_servo>Q_position_target_angle){

```

```
for(Q_servo; Q_servo > Q_position_target_angle ; Q_servo -= 1){
    if(Q_servo == Q_position_target_angle)break;
    servo_test.write(Q_servo);
    delay(20);
}
}
else {
    servo_test.write(Q_servo);
    delay(1000);
}
flow_frequency = 0; // Reset Counter
Serial.print(Q, DEC); // Print ml/min
Serial.println(" ml/min");
}
else {
    Serial.println(" flow rate ");
    lcd.clear();
    lcd.setCursor(0,0);
    lcd.print("FlowRate: ");
    lcd.setCursor(0,1);
    lcd.print( Q);
    //lcd.print(Q_target);
    lcd.print(" ml/min");
}
}
```

```
}

```

### **First Electronic System Simulation/Real Code Proteus with Pulse Generator**

```
#include <Servo.h>

```

```
#include <LiquidCrystal.h>

```

```
Servo servo_test;

```

```
LiquidCrystal lcd(13, 12, 11, 10, 9, 8);

```

```
volatile float flow_frequency; // Measures flow sensor pulses

```

```
float flow_frequency_int=3; //for proteus Simulation with flowmeter signal

```

```
float Q;

```

```
float Q_1;

```

```
float Q_target;

```

```
float flowsensor = 2; // Sensor Input for Flowmeter

```

```
double currentTime;

```

```
double zeroTime;

```

```
double cloopTime;

```

```
int angle=0 ; //Initiation of the servo

```

```
float Q_position_target_angle;

```

```
float Q_servo;

```

```
void flow () // Interrupt function

```

```
{

```

```
    flow_frequency++;

```

```
}

```

```
void setup()
{
  pinMode(flowsensor, INPUT);
  digitalWrite(flowsensor, HIGH); // Optional Internal Pull-Up
  Serial.begin(9600);
  lcd.begin(16, 2);
  attachInterrupt(digitalPinToInterrupt(flowsensor), flow, RISING); // Setup Interrupt
  lcd.clear();
  lcd.setCursor(0,0);
  lcd.print("BIOREACTOR");
  lcd.setCursor(0,1);
  lcd.print("MEDIUM FLOWRATE");

  currentTime = millis();
  zeroTime=millis();
  cloopTime = currentTime;

  servo_test.attach(7); // pinsignal for servomotor
}
void loop ()
{
  currentTime = millis();
  servo_test.write(0);
  // Every second, calculate and print ml/min
  if(currentTime >= (cloopTime + 1000))
```

```

{
  cloopTime = currentTime; // Updates cloopTime
  if(flow_frequency != 0){
    //Pulse frequency (Hz) = K * Q, Where K is the value from the type of Flowmeter in this
case K=7.5
    Q = ((flow_frequency / 7.5)*1000); // Q = flowrate in mL/min */
    Q_target=((flow_frequency_int / 7.5)*1000); //for Proteus simulation of waterflow signal
    lcd.clear();
    lcd.setCursor(0,0);
    lcd.print("FlowRate:");
    lcd.setCursor(0,1);
    lcd.print(Q);
    lcd.print("ml/min");
    Q_1=Q*100; //dar decimales a la funcion map
    Q_servo=map(Q_1,0,1000,0,180); //pump range for flowmeter frequency REAL (0-
1000)ml/min
    Q_servo=Q_servo/100;
    Q_position_target_angle=72; //target of Flowmeter Q=400ml/min for flowmeter
frequency REAL

    if(Q_servo < Q_position_target_angle){
      for(Q_servo; Q_servo < Q_position_target_angle ; Q_servo += 1){
        if(Q_servo == Q_position_target_angle)break;
        servo_test.write(Q_servo);
        delay(50);

```



```
    }  
  }  
  else if(Q_servo>Q_position_target_angle){  
    for(Q_servo; Q_servo > Q_position_target_angle ; Q_servo -= 1){  
      if(Q_servo == Q_position_target_angle)break;  
      servo_test.write(Q_servo);  
      delay(20);  
    }  
  }  
  else {  
    servo_test.write(Q_servo);  
    delay(1000);  
  }  
  flow_frequency = 0; // Reset Counter  
  Serial.print(Q, DEC); // Print ml/min  
  Serial.println(" ml/min");  
}  
else {  
  Serial.println(" flow rate ");  
  lcd.clear();  
  lcd.setCursor(0,0);  
  lcd.print("FlowRate: ");  
  lcd.setCursor(0,1);  
  lcd.print( Q);
```

```

    //lcd.print(Q_target);
    lcd.print(" ml/min");
}
}
}

```

### **Second Electronic System Simulation Code Proteus with Temperature Sensor**

```

const int HP_Pin= A1; // Arduino pin connected to Potentiometer pin

float val;

const int Green_LED_PIN = 4; // Arduino pin connected to LED's pin

const int Red_LED_PIN = 3;

void setup() {
    // put your setup code here, to run once:
    Serial.begin(9600);

    pinMode(Green_LED_PIN, OUTPUT); //green LED for PH sensor
    pinMode(Red_LED_PIN, OUTPUT); //red LED for PH sensor
}

void loop() {
    /// For simulation in Proteus a temperature sensor was used in order to represent a PH sensor
    val=analogRead(HP_Pin);

    float mv=( val/1024.0)*5000;

    float cel = mv/10;

    Serial.print("PH value=");

```

```

Serial.print(ce1);

Serial.println();

delay(1000);

if(ce1>=7 && ce1<=7.4){

    digitalWrite(Green_LED_PIN, HIGH); // turn on LED

    digitalWrite(Red_LED_PIN, LOW);

}

else{

    digitalWrite(Green_LED_PIN, LOW);

    digitalWrite(Red_LED_PIN, HIGH);

}

}

```

### **Second Electronic System Code Proteus with pH Sensor**

```

#include <Wire.h>

#include <LiquidCrystal.h>

LiquidCrystal lcd(13, 12, 11, 10, 9, 8);

float calibration_value = 21.34;

int phval = 0;

unsigned long int avgval;

int buffer_arr[10],temp;

const int Green_LED_PIN = 4; // Arduino pin connected to LED's pin

const int Red_LED_PIN = 3;

```

```
void setup()
{
  Serial.begin(9600);
}

void loop() {
  for(int i=0;i<10;i++)
  {
    buffer_arr[i]=analogRead(A0);
    delay(30);
  }
  for(int i=0;i<9;i++)
  {
    for(int j=i+1;j<10;j++)
    {
      if(buffer_arr[i]>buffer_arr[j])
      {
        temp=buffer_arr[i];
        buffer_arr[i]=buffer_arr[j];
        buffer_arr[j]=temp;
      }
    }
  }
  avgval=0;
```

```

for(int i=2;i<8;i++)
avgval+=buffer_arr[i];
float volt=(float)avgval*5.0/1024/6;
float ph_act = -5.70 * volt + calibration_value;
lcd.setCursor(0, 0);
lcd.print("pH Val:");
lcd.setCursor(8, 0);
lcd.print(ph_act);
delay(1000);

if(ph_act>=7 && ph_act<=7.4){
    digitalWrite(Green_LED_PIN, HIGH); // turn on LED
    digitalWrite(Red_LED_PIN, LOW);
}
else{
    digitalWrite(Green_LED_PIN, LOW);
    digitalWrite(Red_LED_PIN, HIGH);
}
}
}

```

## EES Codes

### Fluid dynamics Parametric Analysis

"Parametric Study for Different Flow Rates"

"\$IFNOT Parametric Study"

D=0.01[m]

"\$ENDIF"

$$A=(\pi*D^2)/4$$

$$U_{inf}=Q_{dot}/A$$

$$F=4.5 \quad \text{"Dimensionless shear stress value"}$$

$$R=2.22E-4 \text{ [m]} \quad \text{"Cambiando el diametro del Scaffold"}$$

$$\rho=\text{density}(\text{Steam\_IAPWS},T=37[C],x=0)$$

$$\mu=\text{viscosity}(\text{Steam\_IAPWS},T=37[C],x=0)$$

\$IFNOT Parametric Study

$$Q_{dot}=2.5E-7[m^3/s]$$

\$ENDIF

$$"Q_{dot}=4.167E-7[m^3/s]"$$

$$\tau_w=(0.5*F*\rho*(U_{inf})^2)/(\text{sqrt}((\rho*U_{inf}*R)/\mu))$$

$$\tau_{w\_dy}=\tau_w*10[\text{dynes}/(\text{cm}^2*\text{Pa})]$$

$$Re=\rho*U_{inf}*D/\mu$$

$$l_e=D*0.06*Re$$

$$l_{e\_cm}=l_e*100[\text{cm}/\text{m}]$$

"Run 11 table 1 is the best optimization with 15cm of the bioreactor chamber"

### Energy Analysis

"Calculations of Pressure drops in the System"

"Data"

$$D1=0.00635[\text{m}] \quad \text{"Internal Diameter of Plastic Tubes"}$$

$D_2=0.01[\text{m}]$  "Internal Diameter of Bioreactor"  
 $\text{tetha}=33.88$  "Enlargement/Contraction angle"  
 $U_x=0.01273[\text{m/s}]$  "Value taken from table 1 Run 11"  
 $L_s=0.03[\text{m}]$  "Scaffold Length"  
 $T=37[\text{C}]$  "Temperature"  
 $V_1=V_2$  "Constant Flow rate"  
 $Q=1\text{E-}6[\text{m}^3/\text{s}]$   
 $A=\pi*(D_1^2)/4$   
 $V_2=Q/A$   
 $z_1=z_2$  "No height variation"  
 $z_2=0$   
 $g=9.81[\text{m/s}^2]$   
 $Re=182.9$  "Old Reynolds value was 45.65"  
 $f=64/Re$  "Friction factor for laminar flow"  
 $L_t=1.5[\text{m}]$  "Old value was 4 [m]"  
 $\rho=\text{density}(\text{Steam\_IAPWS},T=T,x=0)$   
 $\mu=\text{viscosity}(\text{Steam\_IAPWS},T=T,x=0)$   
 $D_h=D_1$  "Hydraulic Diameter of Plastic Tubes"  
 $R_s=2.75\text{E-}4[\text{m}]$  "Old scaffold radius"  
 $R_s=2.22\text{E-}4[\text{m}]$  "Scaffold structural members radius"  
 $R_h=R_s/2$  "Hydraulic Radius"  
 "Energy equation"  
 $\Delta P_T = ((-V_1^2/(2*g)) + (V_2^2/(2*g)) -$   
 $z_1 + z_2 + (f*L_t/D_h)*(U_x^2/(2*g)) + \text{SUM}K*(U_x^2/(2*g)) + (-\Delta P/(\rho*g)))*(\rho*g)$   
 "Minor Losses"

"Gradual Enlargment" "Appendix E Pennoncello"

$$\beta = D_1/D_2$$

$$K_1 = (2.6 * \sin(\theta/2) * ((1 - \beta^2))^2) / \beta^4$$

"Gradual Contraction" "Appendix E Pennoncello"

$$K_2 = (0.8 * \sin(\theta/2) * ((1 - \beta^2))^2) / \beta^4$$

"Pipe Entrance"

$$K_3 = K_4$$

$$K_5 = K_4$$

$$K_4 = 0.78 \quad \text{"Inward Projecting Valve Appendix E Pennoncello"}$$

"Pipe Exit"

$$K_6 = K_7$$

$$K_8 = K_7$$

$$K_7 = 1 \quad \text{"Outward Projecting Valve Appendix E Pennoncello"}$$

"Ball Valve considering  $\beta=1$  and  $\theta=0$ "

$$K_9 = 3 * f$$

$$\text{SUM}K = K_1 + K_2 + K_3 + K_4 + K_5 + K_6 + K_7 + K_8 + K_9$$

"Porous pressure loss (Kozeny-Darcy Equation)"

$$U_x = -1 / (2 * \mu) * (\Delta P / L_s) * R_h^2$$



## Appendix F

### Bioreactor chamber design criteria analysis

*Option 2 > Option 3 > Option 1*

#### 1) Bioreactor chamber criterion Size evaluation

Criteria	Option 1	Option 2	Option 3	$\Sigma+1$	Results
Option 1		0	0	1	0.167
Option 2	1		1	3	0.500
Option 3	1	0		2	0.333
			Sum	6	1

#### 2) Bioreactor chamber criterion Fidelity evaluation

Criteria	Option 1	Option 2	Option 3	$\Sigma+1$	Results
Option 1		0	0	1	0.167
Option 2	1		1	3	0.500
Option 3	1	0		2	0.333
			Sum	6	1

#### 3) Bioreactor chamber criterion Cleanable evaluation

Criteria	Option 1	Option 2	Option 3	$\Sigma+1$	Results
Option 1		0	0	1	0.167
Option 2	1		1	3	0.500
Option 3	1	0		2	0.333
			Sum	6	1

#### 4) Bioreactor chamber criterion DFA evaluation

Criteria	Option 1	Option 2	Option 3	$\Sigma+1$	Results
Option 1		0	0	1	0.167
Option 2	1		1	3	0.500
Option 3	1	0		2	0.333
			Sum	6	1

#### 5) Bioreactor chamber criterion Replicability evaluation

Criteria	Option 1	Option 2	Option 3	$\Sigma+1$	Results
Option 1		0	0	1	0.167
Option 2	1		1	3	0.500
Option 3	1	0		2	0.333
			Sum	6	1

6) Bioreactor chamber criterion **Cost** evaluation

Criteria	Option 1	Option 2	Option 3	$\Sigma+1$	Results
Option 1		0	0	1	0.167
Option 2	1		1	3	0.500
Option 3	1	0		2	0.333
			Sum	6	1

7) **Final results for bioreactor chamber table**

Concept	Size	Fidelity	Cleanable	DFA	Replicability	Cost	$\Sigma$	Results
Option 1	0.048	0.040	0.028	0.028	0.016	0.008	0.167	3
Option 2	0.143	0.119	0.083	0.083	0.048	0.024	0.500	1
Option 3	0.095	0.079	0.056	0.056	0.032	0.016	0.333	2

## Reservoirs design criteria analysis

*Option 1 = Option 2 > Option 3*

1) Reservoir Criterion **Size** evaluation

Criteria	Option 1	Option 2	Option 3	$\Sigma+1$	Results
Option 1		0.5	1	2.5	0.417
Option 2	0.5		1	2.5	0.417
Option 3	0	0		1	0.167
			Sum	6	1

2) Reservoir Criterion **Fidelity** evaluation

Criteria	Option 1	Option 2	Option 3	$\Sigma+1$	Results
Option 1		0.5	1	2.5	0.417
Option 2	0.5		1	2.5	0.417
Option 3	0	0		1	0.167
			Sum	6	1

3) Reservoir Criterion **Cleanable** evaluation

Criteria	Option 1	Option 2	Option 3	$\Sigma+1$	Results
Option 1		0.5	1	2.5	0.417
Option 2	0.5		1	2.5	0.417
Option 3	0	0		1	0.167
			Sum	6	1

4) Reservoir Criterion ***DFA*** evaluation

Criteria	Option 1	Option 2	Option 3	$\Sigma+1$	Results
Option 1		0.5	1	2.5	0.417
Option 2	0.5		1	2.5	0.417
Option 3	0	0		1	0.167
			Sum	6	1

5) Reservoir Criterion ***Replicability*** evaluation

Criteria	Option 1	Option 2	Option 3	$\Sigma+1$	Results
Option 1		0.5	1	2.5	0.417
Option 2	0.5		1	2.5	0.417
Option 3	0	0		1	0.167
			Sum	6	1

6) Reservoir Criterion ***Cost*** evaluation

Criteria	Option 1	Option 2	Option 3	$\Sigma+1$	Results
Option 1		0.5	1	2.5	0.417
Option 2	0.5		1	2.5	0.417
Option 3	0	0		1	0.167
			Sum	6	1

7) ***Final Results for Reservoirs table***

Concept	Size	Fidelity	Cleanable	DFA	Replicability	Cost	$\Sigma$	Results
Option 1	0.119	0.099	0.069	0.069	0.040	0.020	0.417	1
Option 2	0.119	0.099	0.069	0.069	0.040	0.020	0.417	1
Option 3	0.048	0.040	0.028	0.028	0.016	0.008	0.167	2

**Attachment/Connection design criteria analysis**

$$\underline{Option 2 = Option 1 > Option 3}$$

1) Bioreactor attachment criterion ***Size*** evaluation

Criteria	Option 1	Option 2	Option 3	$\Sigma+1$	Results
Option 1		0.5	1	2.5	0.417
Option 2	0.5		1	2.5	0.417
Option 3	0	0		1	0.167
			Sum	6	1

2) Bioreactor attachment criterion ***Fidelity*** evaluation

Criteria	Option 1	Option 2	Option 3	$\Sigma+1$	Results
Option 1		0.5	1	2.5	0.417
Option 2	0.5		1	2.5	0.417
Option 3	0	0		1	0.167
			Sum	6	1

3) Bioreactor attachment criterion ***Cleanable*** evaluation

Criteria	Option 1	Option 2	Option 3	$\Sigma+1$	Results
Option 1		0.5	1	2.5	0.417
Option 2	0.5		1	2.5	0.417
Option 3	0	0		1	0.167
			Sum	6	1

4) Bioreactor attachment criterion ***DFA*** evaluation

Criteria	Option 1	Option 2	Option 3	$\Sigma+1$	Results
Option 1		0.5	1	2.5	0.417
Option 2	0.5		1	2.5	0.417
Option 3	0	0		1	0.167
			Sum	6	1

5) Bioreactor attachment criterion ***Replicability*** evaluation

Criteria	Option 1	Option 2	Option 3	$\Sigma+1$	Results
Option 1		0.5	1	2.5	0.417
Option 2	0.5		1	2.5	0.417
Option 3	0	0		1	0.167
			Sum	6	1

6) Bioreactor attachment criterion ***Cost*** evaluation

Criteria	Option 1	Option 2	Option 3	$\Sigma+1$	Results
Option 1		0.5	1	2.5	0.417
Option 2	0.5		1	2.5	0.417
Option 3	0	0		1	0.167
			Sum	6	1

7) *Final Results for Bioreactor Attachment table*

<b>Concept</b>	<b>Size</b>	<b>Fidelity</b>	<b>Cleanable</b>	<b>DFA</b>	<b>Replicability</b>	<b>Cost</b>	$\Sigma$	<b>Results</b>
Option 1	0.119	0.099	0.069	0.069	0.040	0.020	0.417	1
Option 2	0.119	0.099	0.069	0.069	0.040	0.020	0.417	1
Option 3	0.048	0.040	0.028	0.028	0.016	0.008	0.167	2

## Appendix G



UNIVERSIDAD SAN FRANCISCO DE QUITO

COLEGIO POLITÉCNICO

Mechanical Engineering

Log Sheet # 1

Title: Introduction to the CAPSTONE Project with the tutor	
Date: 08/09/2020	Time: 17:30 – 18:30
Person in Charge: José Alvarez Barreto	

Participants		
Initials	Name	Attendance
EL	Erick Lamiña	X
KO	Kevin Orbea	X
KT	Kevin Taday	X
NA	Nicolás Anguisaca	X

Talked Points:
More in-depth explanation of the project.
Specifications that the design must meet.
Examples of some Bioreactor physical and mechanical requirements.
Explanation of how the stem cells reproduce with shear stress.

Future tasks:
Search for more information about flow perfusion bioreactors.
Brainstorm (ideas) to make an appropriate design.
Check online web platform “Mind Meister”; useful to design diagrams.
Check web page “vwr.com” to have an idea of how a CO2 incubator looks like.



## UNIVERSIDAD SAN FRANCISCO DE QUITO

### COLEGIO POLITÉCNICO

#### Mechanical Engineering

#### Log Sheet # 2

Title: First Deliverable Meeting	
Date: 09/09/2020	Time: 14:30 – 15:00
Person in Charge: Marco León Dunia	

Participants		
Initials	Name	Attendance
EL	Erick Lamiña	X
KO	Kevin Orbea	X
KT	Kevin Taday	X
NA	Nicolás Anguisaca	X

Talked Points:
First deliverable explanation.
Engineering criteria examples.
Consider all the important dates specified in the Syllabus.
Necessary folders that need to be created in “Teams”.



**Future tasks:**

Search for more information to advance with the project.

Upload research papers and all investigations done so far.



## UNIVERSIDAD SAN FRANCISCO DE QUITO

### COLEGIO POLITÉCNICO

#### Mechanical Engineering

#### Log Sheet # 3

Title: Deliverable 2.1	
Date: 15/09/2020	Time: 17:00 – 20:00
Person in Charge: Group 2	

Participants		
Initials	Name	Attendance
EL	Erick Lamiña	X
KO	Kevin Orbea	X
KT	Kevin Taday	X
NA	Nicolás Anguisaca	X

<b>Talked Points:</b>
Brainstorming topics.
Research more journal articles.
Sketch an initial outline for the introduction.
Upload journal articles and research papers found.

**Future tasks:**

Read the journal articles and research papers.

Gain a better and deeper understanding of bioreactors.



**UNIVERSIDAD SAN FRANCISCO DE QUITO**

**COLEGIO POLITÉCNICO**

**Mechanical Engineering**

Log Sheet # 4

Title: Deliverable 2.2	
Date: 16/09/2020	Time: 16:00 – 21:00
Person in Charge: Group 2	

Participants		
Initials	Name	Attendance
EL	Erick Lamiña	X
KO	Kevin Orbea	X
KT	Kevin Taday	X
NA	Nicolás Anguisaca	X

Talked Points:
Read the specific journal articles assigned to each member of the group.
Read the specific patents assigned to each member of the group.
Start an Online Word Document for the introduction.

**Future tasks:**

Keep writing the introduction following the parameters/instructions given in D2L.

Ask Marco Leon about certain homework instructions that were not so clear for us.



## UNIVERSIDAD SAN FRANCISCO DE QUITO

### COLEGIO POLITÉCNICO

#### Mechanical Engineering

#### Log Sheet # 5

Title: Deliverable 2.2 Meeting	
Date: 16/09/2020	Time: 17:30 – 18:15
Person in Charge: Marco León Dunia	

Participants		
Initials	Name	Attendance
EL	Erick Lamiña	X
KO	Kevin Orbea	
KT	Kevin Taday	X
NA	Nicolás Anguisaca	X

Talked Points:
Discussed certain weak points about “Deliverable 1”.
Sketch actual design concepts for the whole system (bioreactor, reservoirs, general assembly).
Check the “Engineering criteria” section and adjust accordingly. Due date extended.

**Future tasks:**

Check CO<sub>2</sub> incubators (Biobase / vwr.com) and peristaltic pumps (Cole-Parmer).

Appoint a meeting with José Álvarez to clarify some issues regarding design parameters.



**UNIVERSIDAD SAN FRANCISCO DE QUITO**

**COLEGIO POLITÉCNICO**

**Mechanical Engineering**

Log Sheet # 6

Title: Deliverable 2.2	
Date: 17/09/2020	Time: 13:00 – 21:00
Person in Charge: Group 2	

Participants		
Initials	Name	Attendance
EL	Erick Lamiña	X
KO	Kevin Orbea	X
KT	Kevin Taday	X
NA	Nicolás Anguisaca	X

Talked Points:
Organize ideas for the introduction of our research paper.
Write the three-page-long introduction assignment.
Upload the pdf version of the document in D2L.



Future tasks:
None left for this specific assignment.
None left for this specific assignment.



**UNIVERSIDAD SAN FRANCISCO DE QUITO**

**COLEGIO POLITÉCNICO**

**Mechanical Engineering**

Log Sheet # 7

Title: Bioreactor Meeting	
Date: 18/09/2020	Time: 17:30 – 18:15
Person in Charge: José Álvarez	

Participants		
Initials	Name	Attendance
EL	Erick Lamiña	
KO	Kevin Orbea	X
KT	Kevin Taday	X
NA	Nicolás Anguisaca	X

Talked Points:
Discussed certain issues: pump power source and optimal working conditions.
Talked about possible scaffold materials: stainless steel, titanium, non-biodegradable plastic.
General questions: shear stress units, simulation software, laminar/ turbulent flow.
General questions: perfusion bioreactor, cell culture basics, pipe diameter, pump specifications

**Future tasks:**

Check CO<sub>2</sub> incubators (Biobase / vwr.com) and peristaltic pumps (Cole-Parmer).

Sketch actual design concepts for the whole system (bioreactor, reservoirs, general assembly).



**UNIVERSIDAD SAN FRANCISCO DE QUITO**

**COLEGIO POLITÉCNICO**

**Mechanical Engineering**

**Log Sheet # 8**

Title: Deliverable 4 (Design Alternatives and Selection)	
Date: 25/09/2020	Time: 11:30 – 23:30
Person in Charge: Group 2	

Participants		
Initials	Name	Attendance
EL	Erick Lamiña	X
KO	Kevin Orbea	X
KT	Kevin Taday	X
NA	Nicolás Anguisaca	X

Talked Points:
Clearly defined alternatives and material selection for every component of the bioreactor system: bioreactor setup, perfusion chamber, reservoirs, and trays (attachments).
3D CAD sketches for all of the previous design alternatives, considering client requirements.
Evidence the selection process, brainstorming, and selection criteria used for the whole design.
Used Riba's corrected weighted criteria ordered method as the selection criteria.

Future tasks:
Detail design will be considered in future deliverables for each component.
Update the final results and tables of the selection criteria for chamber, reservoirs, and trays.



# UNIVERSIDAD SAN FRANCISCO DE QUITO

## COLEGIO POLITÉCNICO

### Mechanical Engineering

#### Log Sheet # 9

Title: Bioreactor Meeting	
Date: 29/09/2020	Time: 17:00 – 19:00
Person in Charge: José Álvarez	

Participants		
Initials	Name	Attendance
EL	Erick Lamiña	X
KO	Kevin Orbea	X
KT	Kevin Taday	X
NA	Nicolás Anguisaca	X

Talked Points:
José evaluated each design presented to him and decided to combine the best out of each one.
There needs to be a material selection that involves non-biodegradable polymers.
He liked very much the Riba's weighted criteria methodology used in an earlier deliverable.
Scaffold is likely to be used for no more than some hours a day. Will use stem cells.

**Future tasks:**

Create a new hybrid bioreactor design using the best features José selected today.

José is interested in seeing the simulation results and a design for the scaffold.



**UNIVERSIDAD SAN FRANCISCO DE QUITO**

**COLEGIO POLITÉCNICO**

**Mechanical Engineering**

Log Sheet # 10

Title: Fluid Mechanics Meeting	
Date: 05/10/2020	Time: 15:30 – 16:00
Person in Charge: Juan Sebastián Proaño	

Participants		
Initials	Name	Attendance
EL	Erick Lamiña	X
KO	Kevin Orbea	X
KT	Kevin Taday	X
NA	Nicolás Anguisaca	X

<b>Talked Points:</b>
Analyze the Darcy equation before and after the porous media, as a first approximation.
Tortuosity plays a big role in everything related to porous materials.
Revise in the simulation what happens with pores of different diameters (small vs. big).



Future tasks:

What do all the terms inside the Darcy equation stand for?

What is tortuosity? Does it apply to the present project?



**UNIVERSIDAD SAN FRANCISCO DE QUITO**

**COLEGIO POLITÉCNICO**

**Mechanical Engineering**

Log Sheet # 11

Title: Bioreactor Meeting	
Date: 14/10/2020	Time: 16:00 – 17:30
Person in Charge: José Álvarez	

Participants		
Initials	Name	Attendance
EL	Erick Lamiña	X
KO	Kevin Orbea	X
KT	Kevin Taday	X
NA	Nicolás Anguisaca	X

**Talked Points:**

A cell can be considered as a really small cylinder with a diameter of 20 micrometers and a height of 2 to 5 micrometers.

Scaffold appropriate dimensions would involve a pore of 300 micrometers and filaments of 300 to 500 micrometers.

The present design will not be used for long term cell culture (not used for many days in a row).

Polystyrene, PLA, PLGA, or PETG could be one of the choices for scaffold material.

**Future tasks:**

Design a scaffold CAD that will be inside the perfusion bioreactor chamber. Choose material.

Investigate on research platform "Pubmed" for more information on perfusion bioreactors.



**UNIVERSIDAD SAN FRANCISCO DE QUITO**

**COLEGIO POLITÉCNICO**

**Mechanical Engineering**

Log Sheet # 12

Title: Deliverable 6 (Calculations Part 1)	
Date: 21/10/2020	Time: 10:30 – 23:30
Person in Charge: Group 2	

Participants		
Initials	Name	Attendance
EL	Erick Lamiña	X
KO	Kevin Orbea	X
KT	Kevin Taday	X
NA	Nicolás Anguisaca	X

**Talked Points:**

Calculations that consider optimal shear stress over the scaffold surface and that guarantee the fluid reaches fully developed flow before reaching the scaffold.

Methodology: start from literature known data and proceed backward in the analysis.

Start by calculating the free stream velocity the fluid will reach before reaching the scaffold, knowing bioreactor physical dimensions, scaffold radius, and optimal shear stress for cell culture.

Evaluate dimensionless wall shear stress equation and find the value for shear stress, with the help of figures from Schlichting (1979), so Reynolds number and entrance length dimensions can be found.

**Future tasks:**

Simulation is still needed to compare and assess the validity of the present calculations.

Check the methodology and final results with Jose Alvarez and Juan Sebastian Proaño.



**UNIVERSIDAD SAN FRANCISCO DE QUITO**

**COLEGIO POLITÉCNICO**

**Mechanical Engineering**

Log Sheet # 13

Title: Deliverable 5 (Risk Analysis)	
Date: 21/10/2020	Time: 9:30 – 23:30
Person in Charge: Group 2	

Participants		
Initials	Name	Attendance
EL	Erick Lamiña	X
KO	Kevin Orbea	X
KT	Kevin Taday	X
NA	Nicolás Anguisaca	X

Talked Points:
Well identified risks, defined and described in important areas for the bioreactor system.
Brainstorming, risk Identification, 5x5 risk matrix, and risk control matrix were presented.
Subcomponent definition, impact, priority, and probability are correctly evaluated in each table.
Design a Gantt schedule to have well-defined dates and realistic planning.

**Future tasks:**

Subcomponent definition still needs some refinement, explicit but a bit too general.

Review new Gantt chart, unforeseen future calculations meetings yet to be added.



# UNIVERSIDAD SAN FRANCISCO DE QUITO

## COLEGIO POLITÉCNICO

### Mechanical Engineering

#### Log Sheet # 14

Title: Fluid Mechanics Meeting	
Date: 23/10/2020	Time: 10:00 – 11:30
Person in Charge: Kevin Orbea	

Participants		
Initials	Name	Attendance
EL	Erick Lamiña	X
KO	Kevin Orbea	X
KT	Kevin Taday	X
NA	Nicolás Anguisaca	X

Talked Points:
Account for maximum allowable limits of the design and add a safety factor for them.
As talked with José, the maximum shear stress needs to be equal to or less than 25 [dyn/cm <sup>2</sup> ].
There are validation parameters for a CFD simulation and verification criteria.
An experiment, a printed version of the scaffold, would be helpful for the final presentation.



**Future tasks:**

Consider and google rule of thumb for CFD. Find other verification methodologies.

Check with Marco for remote access to COMSOL simulation software.

Review data on how to validate and verify simulations.



## UNIVERSIDAD SAN FRANCISCO DE QUITO

### COLEGIO POLITÉCNICO

#### Mechanical Engineering

#### Log Sheet # 15

Title: Group Session	
Date: 29/10/2020	Time: 14:30 – 19:30
Person in Charge: Kevin Taday	

Participants		
Initials	Name	Attendance
EL	Erick Lamiña	X
KO	Kevin Orbea	X
KT	Kevin Taday	X
NA	Nicolás Anguisaca	X

Talked Points:
Where can the biggest pressure losses can be found on the bioreactor system?
Will automation require a Proportional Integral Derivative control (PID)?
All the simulations are going to be carried on COMSOL, not Autodesk CFD.
Appointed a meeting with Juan Sebastián Proaño for Friday (tomorrow).

**Future tasks:**

What exactly is a PID and how does it work?

Read documentation on how to use and operate COMSOL.



# UNIVERSIDAD SAN FRANCISCO DE QUITO

## COLEGIO POLITÉCNICO

### Mechanical Engineering

#### Log Sheet # 16

Title: Deliverable 7 (Calculations Part 2)	
Date: 30/10/2020	Time: 10:30 – 23:30
Person in Charge: Group 2	

Participants		
Initials	Name	Attendance
EL	Erick Lamiña	X
KO	Kevin Orbea	X
KT	Kevin Taday	X
NA	Nicolás Anguisaca	X

Talked Points:
Continued the calculations for the bioreactor system.
Focus on proving the validity of previous analytical solutions made for wall shear stress.
Compare analytical solutions with CFD simulations made using COMSOL simulation software.
Evaluate the system from an energetic perspective, determining general pressure drop.

**Future tasks:**

Update EES code and values for the proceeding improvements of the bioreactor chamber.

A 2D simulation for the scaffold will be required, with more cross-sectional cylinders.



**UNIVERSIDAD SAN FRANCISCO DE QUITO**

**COLEGIO POLITÉCNICO**

**Mechanical Engineering**

Log Sheet # 17

Title: Fluid Mechanics Meeting	
Date: 30/10/2020	Time: 10:30 – 11:30
Person in Charge: Nicolás Anguisaca	

Participants		
Initials	Name	Attendance
EL	Erick Lamiña	X
KO	Kevin Orbea	X
KT	Kevin Taday	X
NA	Nicolás Anguisaca	X

Talked Points:
It is recommended that the group presents an overall progress in many aspects of the project at the same time.
Some equations are helpful for porous material analytical analysis.
Hydraulic permeability is a paramount issue to consider in porous experiments and applications.
There needs to be a way to validate the simulation in COMSOL.

**Future tasks:**

Revise on literature losses due to porous materials. Check Darcy's equation and related.

Check formula to display shear stress in COMSOL.

Review data on how to validate and verify simulations.



## UNIVERSIDAD SAN FRANCISCO DE QUITO

### COLEGIO POLITÉCNICO

#### Mechanical Engineering

#### Log Sheet # 18

Title: Group 2 Meeting	
Date: 04/11/2020	Time: 14:30 – 15:30
Person in Charge: Marco Dunia	

Participants		
Initials	Name	Attendance
EL	Erick Lamiña	X
KO	Kevin Orbea	X
KT	Kevin Taday	X
NA	Nicolás Anguisaca	X

Talked Points:
Discussed the project progress, and how the simulations were developing.
Automation is still a delicate point for the bioreactor system.
Experiment design is a major consideration from this point onwards.
The next deliverable involves a bunch of construction process sheets.



**Future tasks:**

For next week drawings and CAD design needs to be presented during class hour.

Improvements need to be done for experiment design, automation, and simulation.



## UNIVERSIDAD SAN FRANCISCO DE QUITO

### COLEGIO POLITÉCNICO

#### Mechanical Engineering

#### Log Sheet # 19

Title: Deliverable 8 (Progress Report)	
Date: 08/11/2020	Time: 11:30 – 23:30
Person in Charge: Group 2	

Participants		
Initials	Name	Attendance
EL	Erick Lamiña	X
KO	Kevin Orbea	X
KT	Kevin Taday	X
NA	Nicolás Anguisaca	X

Talked Points:
Big deliverable containing a summary of everything designed and simulated until now.
The team worked in every section of the rubric, for instance, problem statement, problem specification, design concepts and selection, front matter, etc.
The engineering standards was a complicated section due to the fact we knew nothing about it.
Results were very captivating and encouraging. The simulation values corresponded to the analytical solution found in textbooks.

**Future tasks:**

Further testing with the simulation is required, a 3D model perhaps.

Automation, experiment design, and verification are keywords for future deliverables.



## UNIVERSIDAD SAN FRANCISCO DE QUITO

### COLEGIO POLITÉCNICO

#### Mechanical Engineering

#### Log Sheet # 20

Title: Deliverable 9a (Design for manufacturing)	
Date: 17/11/2020	Time: 12:30 – 23:30
Person in Charge: Group 2	

Participants		
Initials	Name	Attendance
EL	Erick Lamiña	X
KO	Kevin Orbea	X
KT	Kevin Taday	X
NA	Nicolás Anguisaca	X

Talked Points:
Each member was randomly assigned a research topic from the general subject.
Four important topics: design for manufacturing, assembly, maintenance, and end-of-life.
In each, an example regarding the bioreactor project was included.
To generate examples for each topic was a mental exercise.

Future tasks:

None for this particular deliverable. It was more a research task.



# UNIVERSIDAD SAN FRANCISCO DE QUITO

## COLEGIO POLITÉCNICO

### Mechanical Engineering

#### Log Sheet # 21

Title: Validation and Verification Meeting	
Date: 19/11/2020	Time: 16:00 – 14:45
Person in Charge: Juan Sebastián Proaño	

Participants		
Initials	Name	Attendance
EL	Erick Lamiña	
KO	Kevin Orbea	
KT	Kevin Taday	X
NA	Nicolás Anguisaca	

Talked Points:
Discussed ASME V&V 20. Will only use it as reference material or as roughly as possible.
Kinematic, equivalent, and symmetric laws of similarity for fluid mechanics.
Important aspects to try to control: pressure drop, volumetric flow rate, and flow regime.
General view of how the final presentations will be taking place.

**Future tasks:**

Check "Laws of Similarity" for fluid mechanics.

Research for automation, specifically a book called Modern Control Engineering by K. Ogata.



**UNIVERSIDAD SAN FRANCISCO DE QUITO**

**COLEGIO POLITÉCNICO**

**Mechanical Engineering**

Log Sheet # 22

Title: Deliverable 10 (Mechanical Drawings)	
Date: 24/11/2020	Time: 13:30 – 23:30
Person in Charge: Group 2	

Participants		
Initials	Name	Attendance
EL	Erick Lamiña	X
KO	Kevin Orbea	X
KT	Kevin Taday	X
NA	Nicolás Anguisaca	X



**Talked Points:**

Third iteration for bioreactor scaffold and perfusion column. Probably will need another one.

Second iteration for the reservoirs. Joints and communications mechanisms were revised.

New hybrid assembly for the entire system. Change CAD software, from Inventor to Fusion 360.

Drawings from all components of the bioreactor. Followed mechanical drawing class guidelines.

**Future tasks:**

The perfusion chamber is okay. Scaffold next iteration will depend on 3d simulation in COMSOL.

The hybrid bioreactor system would probably need some minor tweaks for the final presentation.



## UNIVERSIDAD SAN FRANCISCO DE QUITO

### COLEGIO POLITÉCNICO

#### Mechanical Engineering

#### Log Sheet # 23

Title: Group 2 Meeting	
Date: 25/11/2020	Time: 14:30 – 14:55
Person in Charge: Marco León Dunia	

Participants		
Initials	Name	Attendance
EL	Erick Lamiña	X
KO	Kevin Orbea	X
KT	Kevin Taday	X
NA	Nicolás Anguisaca	X

Talked Points:
Project progress. Special interest in 3D printing manufacturers for the scaffold.
There is a standard format to present the project and to store it in the university library.
Final Portfolio needs to be arranged according to its corresponding rubric.
Be very careful with references and bibliography.

**Future tasks:**

Contact former USFQ student “Andy” for information about 3D printing.

Check the portfolio rubric and the format needed to hand in the final report to the USFQ library.



# UNIVERSIDAD SAN FRANCISCO DE QUITO

## COLEGIO POLITÉCNICO

### Mechanical Engineering

#### Log Sheet # 24

Title: Group 2 Meeting	
Date: 27/11/2020	Time: 14:30 – 15:30
Person in Charge: Marco Dunia	

Participants		
Initials	Name	Attendance
EL	Erick Lamiña	X
KO	Kevin Orbea	X
KT	Kevin Taday	X
NA	Nicolás Anguisaca	X

Talked Points:
Marco needs to see a peristaltic pump dimensioning for the project (next week).
A study on energy consumption will be necessary for the entire bioreactor system.
Check if there is any chance to control the temperature of the system in another way.
Next meeting will be on Tuesday during class hour.

**Future tasks:**

Analyze the automation section of the project.

Remember to schedule a recurring meeting with Juan Sebastián Proaño on “Teams”.



**UNIVERSIDAD SAN FRANCISCO DE QUITO**

**COLEGIO POLITÉCNICO**

**Mechanical Engineering**

Log Sheet # 25

Title: Group Session	
Date: 01/12/2020	Time: 13:30 – 23:30
Person in Charge: Nicolás Anguisaca	

Participants		
Initials	Name	Attendance
EL	Erick Lamiña	X
KO	Kevin Orbea	X
KT	Kevin Taday	X
NA	Nicolás Anguisaca	X

Talked Points:
Improvement of two EES simulations, with new velocity and scaffold diameter.
Updated simulation in COMSOL, similar results to the previous ones obtained.
Automation is still in progress. It has proven to be a challenging aspect of the project.
Keep adding new log sheets. Finish some of the past log sheets as well.

**Future tasks:**

A meeting with José is necessary to check the new results: bioreactor design and biological implications.

Revise and add more scaffold filaments for the 2D simulation in COMSOL.



## UNIVERSIDAD SAN FRANCISCO DE QUITO

### COLEGIO POLITÉCNICO

#### Mechanical Engineering

#### Log Sheet # 26

Title: Bioreactor Meeting	
Date: 02/12/2020	Time: 16:15 – 17:15
Person in Charge: José Álvarez	

Participants		
Initials	Name	Attendance
EL	Erick Lamiña	X
KO	Kevin Orbea	X
KT	Kevin Taday	X
NA	Nicolás Anguisaca	X

Talked Points:
Presented a parametric table to José with important values for different volumetric flow rates.
Explained the way an energetic analysis was carried on for the system. José agreed.
It is viable to gather pressure drop information from similar peristaltic pumps.
The general design of the entire bioreactor system pleases José and almost met his needs.



**Future tasks:**

José recommended to use only 20 to 30 ml/min for the volumetric flow. It will change some minor things in the other simulations and calculations.

Design a completely porous scaffold for the project. It would be better if it has a filament diameter of 200 micrometers and a porous size of 300 micrometers.



## UNIVERSIDAD SAN FRANCISCO DE QUITO

### COLEGIO POLITÉCNICO

#### Mechanical Engineering

#### Log Sheet # 27

Title: Deliverable 9b	
Date: 30/11/2020	Time: 10:30 – 23:30
Person in Charge: Group 2	

Participants		
Initials	Name	Attendance
EL	Erick Lamiña	X
KO	Kevin Orbea	X
KT	Kevin Taday	X
NA	Nicolás Anguisaca	X

Talked Points:
What are some manufacturing technologies and components to assemble for the bioreactor?
Gantt Diagram/Chart for the process that could and will take place after the design
CAD designs and CAD drawings for the key parts of the perfusion bioreactor system
Dimensioning and tolerance verification for scaffold, reservoirs, and perfusion chamber

**Future tasks:**

Check overall presentation and clarity of the Deliverable 9b work

Talk with Jose. Do the dimensions of the actual scaffold accomplish his initial requirements?



HAYEK INTERNACIONAL CIA. LTDA.  
 AV. SEIS DE DICIEMBRE 7428 Y AV. EL INCA  
 RUC: 1790893073001  
 TELÉFONO: 2410193  
 CORREO ELECTRONICO: atencionhayek@gmail.com

Descripción	Cantidad	Pre. Unit	Pre. Tot
TAPON MACHO 75MM	2.00	1.61	3.22
PLASTIGAMA UNION BRONCE MANGUERA 1/2*3/4	1.00	1.79	1.79
SILICON TRANSP 1200 ABRO	1.00	3.39	3.39
SUBTOTAL GDO:			8.40
SUBTOTAL 0%:			0.00
SUBTOTAL No objeto de IVA:			0.00
SUBTOTAL Sin Impuestos:			8.40
IVA:			1.01
VALOR TOTAL:			9.41

CLIENTE: ROCIO PERALTA

CED/RUC: 1711492213

FACTURA Nro: 001-011-000017445

Fecha Emisión: 2020-12-12

Revise su factura electrónica ingresando a:  
[www.mifabricacion.com.ec/minegocioportal/](http://www.mifabricacion.com.ec/minegocioportal/)

Usuario: 1711492213

Contraseña: 1711492213

Este comprobante no es un documento

Vendedor: HAYEK INTERNACIONAL

Forma Pago: Efectivo

Numero Autorización  
 121220200117906930730012001011000017445340830221

DECLARE A TIEMPO SU IMPUESTO A LA RENTA.

Kevin Taday

①

Brainstorm:

- fully developed flow
- spiral
- 3 different flasks
- Volumetric flow rate
- as most compact as possible
- entrance length ( $L_e$ )
- $\phi$  tubería
- Modelo bomba peristáltica.
- bomba peristáltica (6 tubos al mismo tiempo)
  - ↳ Cole parmer
  - ~~Wetlab~~
- incubadoras  $\rightarrow$  vwr.com
- 4 repisas - 16 bio reactores
  - ↳ 4 bio reactores en cada repisa?
  - ↳ 32 reservorios
- Bio reactor (para José): cámara con reservorios.

Dimensiones y fórmulas

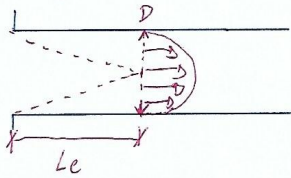

• for turbulent flow ( $Re > 4000$ )

$$\frac{L_e}{D} = 4.4 (Re)^{1/6}$$



•  $D_{int} = 1/4'' = 0.635 [cm]$

$L_{total} = 50 [ft] = 15.24 [m]$

• Volumetric flow =  $0.4 - 85 [mL/min] = 6.7 \times 10^{-5} - 1.4 \times 10^{-6} [m^3/s]$

$\rightarrow \frac{2 mL}{min} = 3.33 \times 10^{-8} \left[ \frac{m^3}{s} \right]$

$\rightarrow \frac{6 mL}{min} = 1 \times 10^{-7} \left[ \frac{m^3}{s} \right]$

•  $Re = \frac{\rho \cdot V \cdot D_{int}}{\mu} = \frac{V \cdot D_{int}}{\nu}$

• Ecuación energía:

$$\frac{P_1}{\gamma} + \frac{V_1^2}{2g} + Z_1 = \frac{P_2}{\gamma} + \frac{V_2^2}{2g} + Z_2 + H_L$$

head loss  $\nearrow$

• Shelf dimensions =

Caron 708L

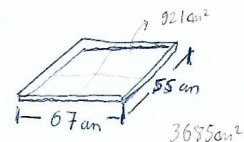

②

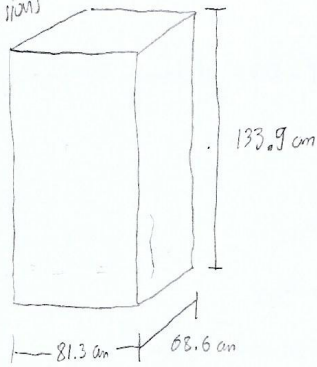
interior  
dimensions

(\$19,500)

- 4 shelves  $\approx 33$  cm
- 5 shelves  $\approx 27$  cm
- 6 shelves  $\approx 22$  cm

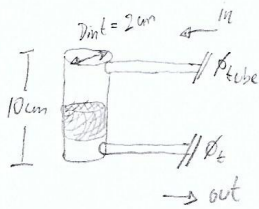

- Physical properties of  $H_2O$  at  $37^\circ C$ :

$$\rho = 993.25 \left[ \frac{kg}{m^3} \right]$$

$$\mu = 6.9628 \times 10^{-4} \left[ \frac{N \cdot s}{m^2} \right]$$

$$\nu = 7.0087 \times 10^{-7} \left[ \frac{m^2}{s} \right]$$

- Fluid velocity ( $\rho_{tube} = 6.35 \times 10^{-3} [m]$ )

$$\rightarrow \frac{2 \text{ mL}}{\text{min}}$$

$$Q = \dot{V} = A \cdot v$$

$$\therefore v = \frac{3.33 \times 10^{-8}}{\pi \left( \frac{6.35 \times 10^{-3}}{4} \right)^2} \left[ \frac{m^3/s}{m^2} \right] = 4.2059 \times 10^{-3} \left[ \frac{m}{s} \right]$$

$$v = \frac{Q}{A}$$

$$\underline{v = 4.20 \times 10^{-3} [m/s]}$$

$$\rightarrow \frac{6 \text{ mL}}{\text{min}}$$

$$\underline{v_6 = 0.0126 [m/s]}$$

$$\rightarrow \frac{10 \text{ mL}}{\text{min}}$$

$$\underline{v_{10} = 0.0211 [m/s]}$$

$$\rightarrow \frac{30 \text{ mL}}{\text{min}}$$

$$v_{30} =$$



• Re number

(3)

$$Re_2 = \frac{\rho_{H_2O} \cdot V_2 \cdot D_{int}}{\mu} = \frac{(998.25 \frac{kg}{m^3}) (4.10 \times 10^{-3} m/s) (2 \times 10^{-2} m)}{(6.9628 \times 10^{-4} \frac{N \cdot s}{m^2})} = 119.7$$

$Re_2 = 120$

$Re_5 = 359$

$Re_{10} = 601$

by  $\frac{1}{r^2} \cdot \frac{r}{n \times}$

Variar  $\rightarrow$  CO<sub>2</sub> incubator

$\rightarrow$  reservorios y formulas

$Le = 0.06 Re \cdot D_{int}$

$Le = 0.06 (604.7) \cdot (8 \text{ cm})$

$Le = 290 \text{ [cm]}$

oo

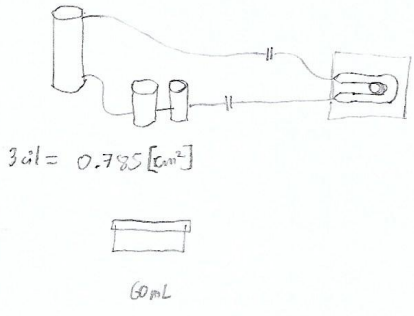

$3 \mu l = 0.785 \text{ [cm}^2\text{]}$

Simulacion  
Lo bioreservorios compactos

Control  $\rightarrow$  flujo

> Alguna parte control

> ¿Control?

• velocidad?  
vaina? flujo peristaltico

• reservorio? matraz? ✓

• Flujo turbulento  $\rightarrow$  laminar

$\rightarrow$  nano de precipitacion

o glass beaker with

RESERVORIOS  $\rightarrow$  2 el volumen del reactor

$\rightarrow$  mejor cilindrico (menos contraccion)  
con tapa

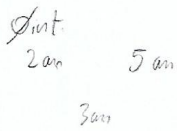

max 300 micras

todo compacto  $\rightarrow$  todo junto

tradeoff

hada



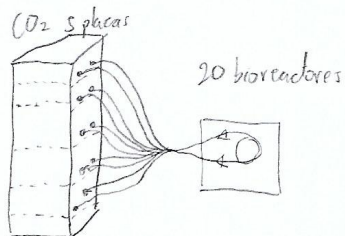
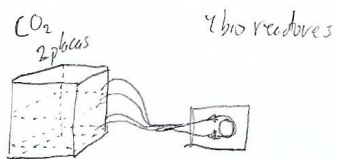

Preguntas

- fibra
- antares
- tapa y sujeción? sellado?
- Control

- Solución A  
Solución B  
" " C  
" " D  
" " E  
" " F

- Sistema Andamio?
- Control (alguna cosa sellada)
- Puntos críticos?
- Cámara flujo laminar.

Diseño

9

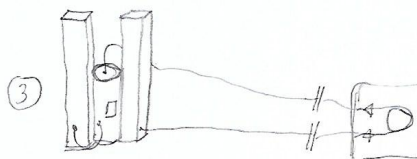
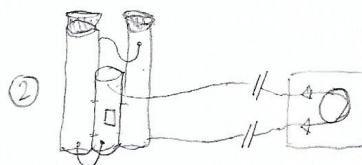
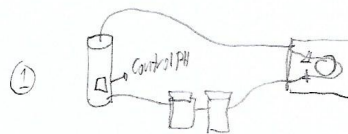

Abrir bioreactor para introducir matriz?

- Control de Caudal.
- Cambiar medio cada tres días
- Medidor de pH (en los reservorios)
- " " " Oxígeno disuelto

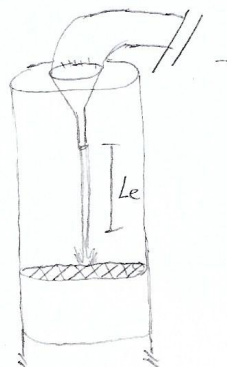

- conductímetro
- conductímetro
- sensor de flujo

⑤

- Temas Afines (3) 3 tópicos: -Arquitos contemporáneos locales  
- Breakthroughs

- Argumentar: ¿Xg son 3 temas son asuntos contemporáneos?  
¿Xg son break throughs?  
¿Cómo enseñaremos los cosas?

- Usar referencias/ Time New Roman 12/ renglón seguido/ hasta 3 renglones.

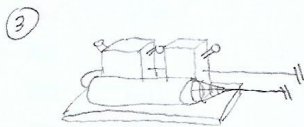
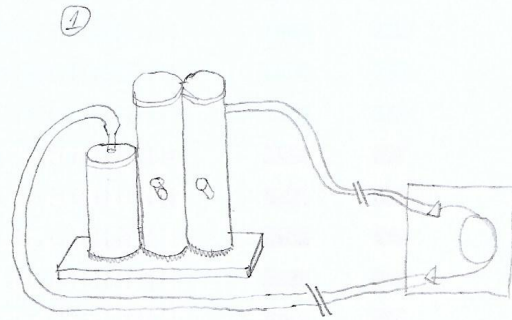
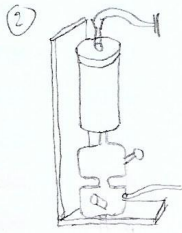

- vidrio?
  - plástico?
  - Matraz
  - V. precipitación
  - filtro de Jemuga
- } Reservorios

- > Acrílico transparente } Columna
- > 3D plástico } perturbación

-> rosca sellada.

- > material tapa:
  - plástico
  - acero inox

- Thowlatran jar lids

- autoclaveable jar lids

- Tissue culture flasks

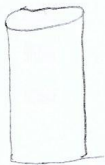

$$\pi \left(\frac{5\text{cm}}{2}\right)^2 \cdot 10\text{cm}$$

$$= 125\pi \text{ cm}^3$$

$$= 392.7 \text{ cm}^3 = 392.7 \text{ mL}$$

$$\approx 400 \text{ mL}$$

$$\frac{3}{8} + \frac{1}{16} = \frac{7}{16}$$

$$= 11.11 \text{ mm}$$

$$\frac{3}{8}'' = 9.525 \text{ mm}$$

$$\frac{1}{8}'' = 1.587 \text{ mm}$$

$$\frac{1}{2} = 06 \text{ mm}$$